

Scanning Laser Range Finder Card-URG UCT-10LCM

User's Manual



目次

1. Introduction	3
1.1 About this Document/Manual	3
1.2 Applicable Products	3
1.3 Special Markings and Symbols	3
1.4 Cautions	3
1.5 Registered Trademarks	4
2. Safety Precautions	5
2.1 General Precautions	5
2.2 Operating Environment	5
2.3 Installation of UCT	5
2.4 Wiring	6
2.5 Inspection and Maintenance	6
3. Product Overview	7
3.1 Features of UCT-10LCM	7
3.2 Components of UCT-10LCM	9
3.3 Operation Principle	11
3.4 Emission Layer Setting	12
3.5 Area Configuration	13
3.6 Relationship between Layers, Regions, and Outputs	16
3.6.1 Outputs in Multi-layer Mode	16
3.6.2 Outputs in Single-layer Mode	18
3.7 Area Switching	19
3.8 Detection Condition	19
3.9 ON/OFF delay	21
3.10 Hysteresis Function of Detection Area	32
3.11 Scan Skip Function	34
3.12 Reference Functions	36
3.13 Setting of UCT	38
3.14 Output	42
3.14.1 Output 1 to Output 5	42
3.14.2 Malfunction Output	43
3.14.3 Reference Output	43
3.15 Input	43
3.15.1 Area Input	43
3.15.2 Reference Input	43
3.16 Indicator Lamp	44
3.17 Laser Spot	45

3.18 Close Range Sensitivity Filter	46
4. Installation	49
4.1 Light interference.....	49
4.2 Mutual interference.....	50
5. Wiring	52
5.1 Precautions	52
5.2 Power Supply	52
5.3 Lead Wire Colors and Functions	53
5.3.1 Lead Wire Colors and Functions of UCT-10LCM	53
5.4 Input/Output Circuit.....	54
5.4.1 Input Circuit.....	54
5.4.2 Output Circuit	54
6. Setting of Area Designer Prime	55
6.1 Area Designer Prime	55
6.2 System Requirement	55
7. Communication	56
7.1 Ethernet Setting	56
7.1.1 Initial Value	56
7.1.2 Changing IP Address	56
7.2 IMU Setting	56
7.3 Communication Protocol.....	56
7.4 Detail on Measurement Values	57
8. Inspection and Maintenance	58
8.1 Pre-operation Inspection	58
8.2 Operation Inspection.....	59
8.3 Daily Inspection	59
8.4 Periodical Inspection.....	60
8.5 Cleaning the Optical Window.....	61
9. Troubleshooting.....	62
10. Specification	64
11. Applicable Directives and Standards	67
12. Package Contents.....	68
13. External Dimensions.....	69
14. Revision History	70



1. Introduction

This user's manual is designed with the purpose of providing guidelines and instructions for the machine user or system designer while operating, installing, wiring and servicing UCT sensor (UCT-10LCM).

1.1 About this Document/Manual

UCT's features, installation and handling method are described in this document.

- Make sure to read carefully and understand this document before installation, wiring, operation, inspection and maintenance.
- Users should have a copy of this document at an easy-to-access place for quick reference.
- Any modifications or disassembly of UCT is prohibited. Modifications will affect sensor performance and detection capability that could lead to critical injury and death.
- Any modifications or disassembly of UCT will void the warranty.
- All information in this user's manual is subject to change without prior notice. For the latest information visit our company's website <http://www.hokuyo-aut.jp/>

1.2 Applicable Products



This document is for the following sensor models.

- UCT-10LCM

1.3 Special Markings and Symbols

Markings and symbols are used in this document to alert the user about safety-related issues.

Follow the instructions of these special markings and symbols to ensure safety during the operation.

Mark	Meaning
 Danger	Procedures that could lead to dangerous situation, critical injury or death if not carried out properly
 Caution	Procedures that could lead to dangerous situations, serious injury or physical damage if not carried out properly
Note	Points that should be considered for proper operation

1.4 Cautions

- UCT has been shipped upon strict quality control. If you find any defect in the products contact the nearest distributor or sales representative.
- Hokuyo cannot be held responsible for damages or failure due to misuse of the product.
- The actual product may differ from the illustrations and figures in this document as they are used for explanatory purposes only.

1.5 Registered Trademarks

- Microsoft[®], Windows[®] are the registered trademarks of Microsoft Corporation USA.
- Besides that, other product names and company names mentioned are trademarks or registered trademarks of their respective companies.



2. Safety Precautions

Make sure to read the following safety precautions for the correct use and operation of UCT.

2.1 General Precautions

- UCT uses laser radiation for detecting objects
- Perform pre-operation tests in order to verify the performance of UCT.
- User should prepare test pieces for detection capability verification test. The test piece should emulate the smallest object that is intended to be detected during operation.
- Operate UCT within the specifications described in this User's manual. Perform necessary maintenance to prevent deterioration of UCT's detection capability. (Refer to Chapter 8.)
- Do not modify or disassemble UCT to ensure its housing rating (IP65) is maintained. Such modifications will void the warranty.
- UCT is not a safety device. Do not use this sensor for the purpose of protecting humans.
- When dust or water droplets adhere to the optical window, the detection capability of UCT decreases. Therefore, please ensure that the optical window is kept clean at all times. (Refer to Chapter 8-5.)
- UCT should be disposed as industrial waste or in accordance with the local disposal directives.
- Caution-Use of controls or adjustments or performance of procedures other than those specified herein may result in hazardous radiation exposure.

2.2 Operating Environment

- Make sure that UCT's operating environment is within the stated specification (temperature, humidity, vibration, ambient light, etc.)
- Do not use or mount UCT near devices that could generate strong electromagnetic waves as it could affect the operation of the sensor.
- Do not use or mount UCT in dusty, smoky, or misty environments, or where corrosive substances are present. Working under such environments may decrease the detection capacity of the sensor.
- This product is for indoor use only.

2.3 Installation of UCT

- Install UCT on a firm surface or structure to avoid displacement.
- Install UCT where there is no influence of a shock or vibration.
- Shock and vibration should not loosen the mounting. Detection results will be different if the sensor is displaced due to such conditions.
- Mutual interference can occur when two or more UCT sensors are mounted at the same detection plane. (Refer to Chapter 4-1.)
- UCT should be mounted with a provision of sufficient space for maintenance.
- UCT should be mounted where indicator lamps are easily visible.
- Do not put any object in the detection area of UCT. It is not possible for the sensor to detect objects



that lie behind the obstacle.

- Do not add any protective materials such as glass, transparent cover, etc, in the front of the optical window. This may lead to loss of detection capability of UCT.
- Avoid direct sunlight as it may cause sensor malfunction. (Refer to Chapter 4-2.)
- Increasing the response time will also increase the stability of UCT. However, this will reduce the detection capability towards moving objects. Users must perform pre-operation tests before using this function.
- When using products with similar wavelengths, install them on different optical plane and avoid interference with UCT.
- If the communication is unstable, it is recommended to attach a ferrite core on the Ethernet cable.

2.4 Wiring

- Switch off all the power supplies during wiring.
- When a converter is used for supplying the power, make sure it fulfills the following requirements.
 - a) A rated output voltage within the range of DC 10V to 30V (above 1A)
 - b) The power supply complies with the requirements of electrical compatibility regulations (EMC) of the respective country, states and district.
- All the input/output signal cables should be installed away from machines, power lines and high-voltage cables.

2.5 Inspection and Maintenance

- User must perform inspection and maintenance by referring to the following checklists provided in this document.(Refer to Chapter 8.)
 - a) Pre-operation inspection
 - b) Operation inspection
 - c) Daily inspection
 - d) Periodical inspection
 - e) Cleaning the optical windowChecklists in this document are provided as basic guidelines while performing the test and maintenance. Users must perform additional inspection and maintenance tasks deemed necessary for the respective applications.
- Stop the machine and system if faults are detected during these tests.
- Clean the optical window when it gets contaminated. If the optical window is damaged it should be replaced by a new one.



3. Product Overview

- This sensor scans a 100-degree field using a laser beam ($\lambda=905\text{nm}$), measuring the distance to the target and calculating its coordinates based on the step angle. It has two functions: one that outputs distance data per angle via communication (LX mode), and another that detects obstacles within a designated area (LA mode).
- It features three scan layers with different vertical angles and supports VSSP, enabling easy conversion to 3D coordinates.
- LX mode supports multi-echo data output, while LA mode allows for selected single-echo data output.
- With the dedicated application, it is possible to switch between multi-layer mode, which activates three emission layers, and single-layer mode, which activates only one selected layer.

This chapter describes the features and properties of UCT-10LCM.

3.1 Features of UCT-10LCM

● Basic Functions

- ▶ Maximum 2 of areas can be configured.
- ▶ Easy configuration using the setup application *Area Designer Prime*
 - ▶▶ Teaching function
 - ▶▶ Area rotation function
 - ▶▶ Measurement data log saving and playback function
- *Refer to the *Area Designer Prime* Instruction Manual (C-41-02680).
- ▶ Malfunction output: Activates malfunction output according to self-diagnosis function.
- ▶ LED indicates UCT's status
- ▶ SCIP communication (TCP/UDP) / VSSP communication supported

For details, refer to the SCIP Communication Specification (C-42-04609) and the VSSP Communication Specification (C-42-04610). (Only LX mode supports multi-echo commands.)

●Configurable Functions

- ▶ Hysteresis function of detection area
- ▶ ON delay and OFF delay function
- ▶ Minimum detectable object setting
- ▶ Reference Function
- ▶ Reference input assignment function
- ▶ Output logic inversion function
- ▶ Mode selection(LX \leftrightarrow LN)
- ▶ UDP destination IP address setting
- ▶ Emission layer selection
- ▶ Rain filter function
- ▶ Interference reduction filter
- ▶ Close range sensitivity filter
- ▶ Echo selection
- ▶ Scan skip function



- This product is an auxiliary safeguard product only. It is not a safety device. In the event of a product malfunction, it could cause a serious accident. Therefore, use additional safeguarding devices such as bumpers, and take necessary measures, such as backup circuits.

3.2 Components of UCT-10LCM

Figure 3-1 shows the components of UCT

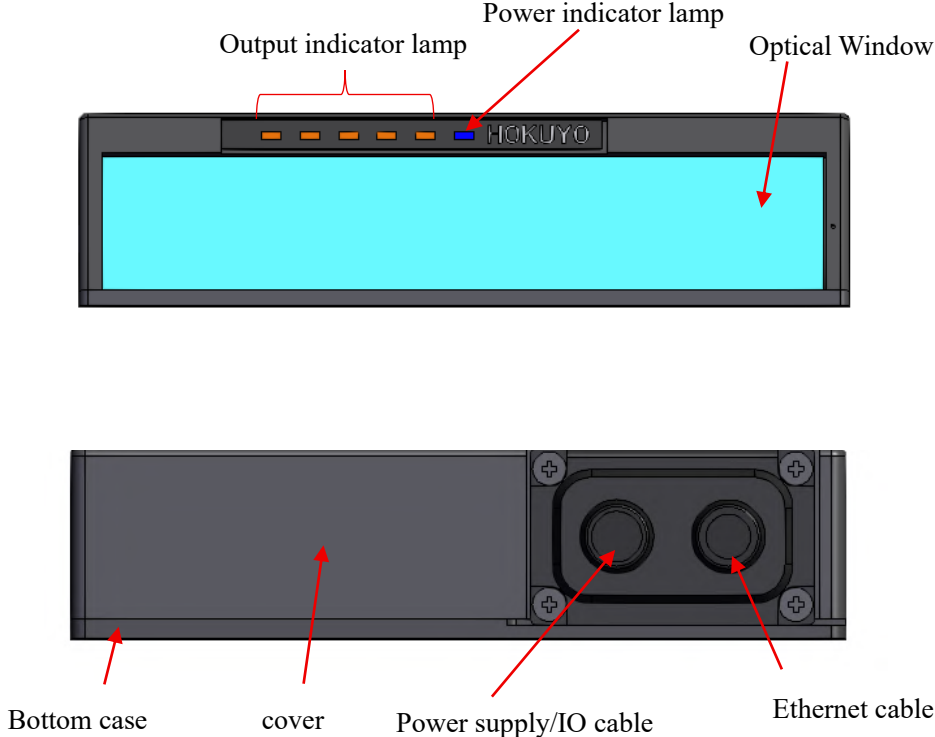

Fig 3-1 UCT components

Figure 3-2 shows the scanning range and detection zone origin of UCT, while figure 3-3 shows its optical axis height guide.

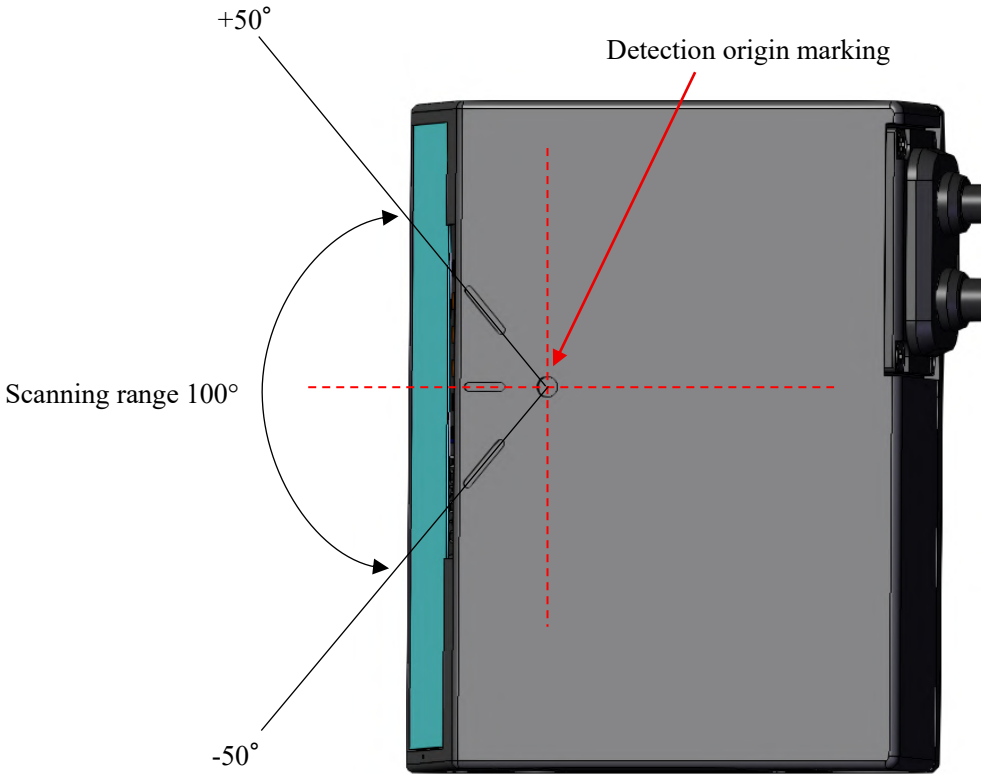

Fig 3-2 Scanning range and detection zone origin (Top view)

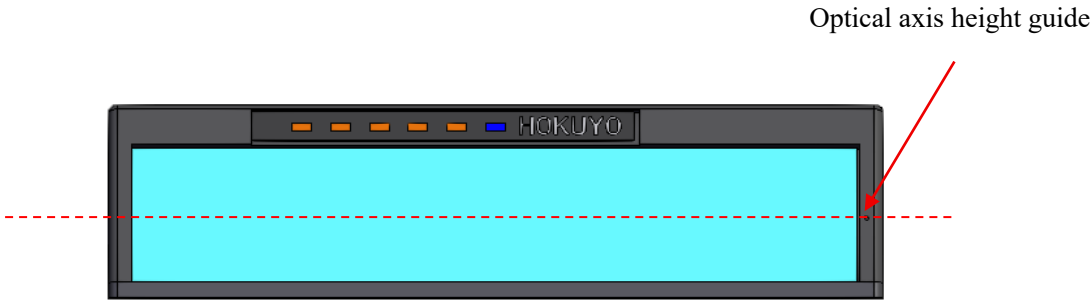

Fig 3-3 Optical axis height guide (Front view)

3.3 Operation Principle

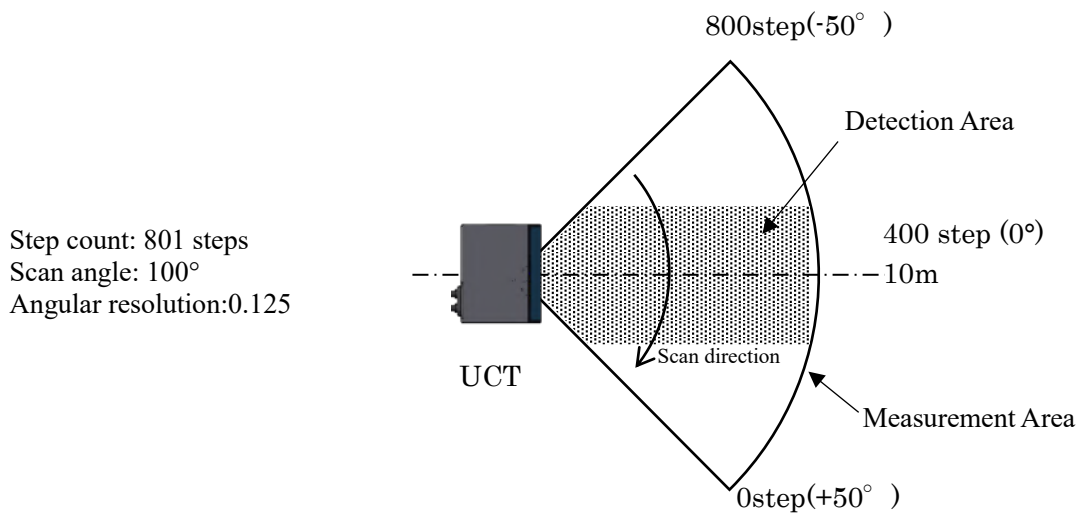

Fig 3-4 Scanning range

Figure 3-4 shows the scanning range of UCT. The sensor emits pulsed laser beams which reflect on a rotating mirror forming a fan-like scanning pattern over 100 ° field. When the emitted laser beams are reflected back from an object, its distance is measured by applying the Time-of-Flight (TOF) principle. The duration of the reflected pulsed laser beam is taken for distance calculation as shown below.

$$L = \frac{1}{2} \times C \times T$$

Where, L=Distance of the object
 C= Speed of the light
 T=Time difference

The operation principle of TOF is shown in schematic diagram (Figure 3-5) below

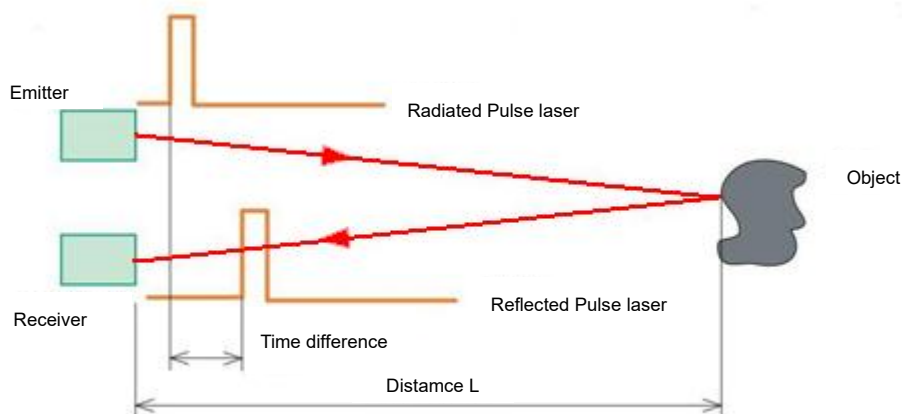

Fig 3-5 TOF operation principle

3.4 Emission Layer Setting

UCT is equipped with three scanning layers, each with a different vertical angle. The emission layer can be configured using AreaDesigner Prime, the setup application accessible via Ethernet.

In the multi-layer mode, where all three layers emit, the layers emit in the order Layer 1→2→3. Data output and output evaluation are performed sequentially every 16.7 ms.

In the single-layer mode, only one of three layers emit, and you can select which layer to use. The unselected layers remain off, so no data output or output evaluation is performed. Because emission occurs once every three layers, data output and output evaluation are performed every 50 ms. The output holds the value from the most recently emitted layer.

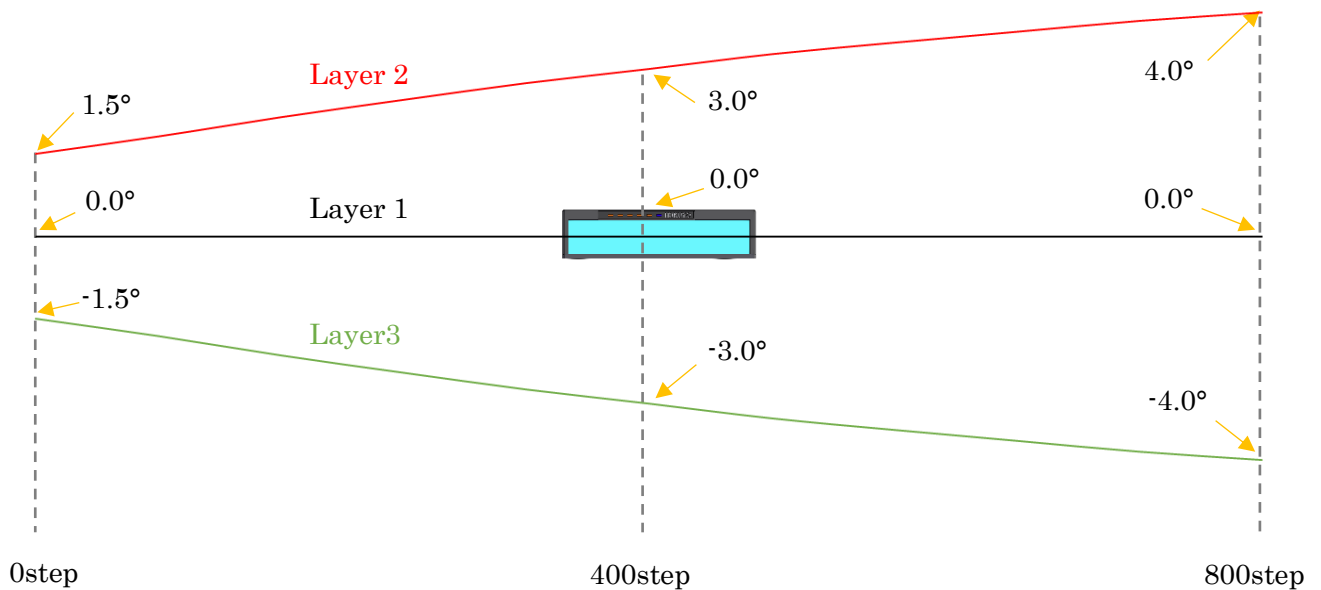

Fig 3-6 Optical axis image in a concentric distance layout.

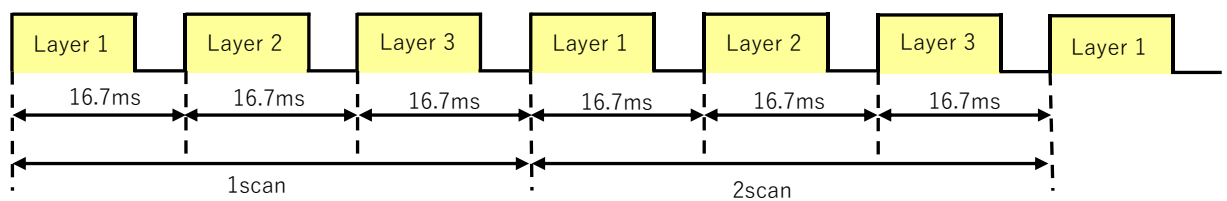

Fig 3-7 Multi-layer mode emission image

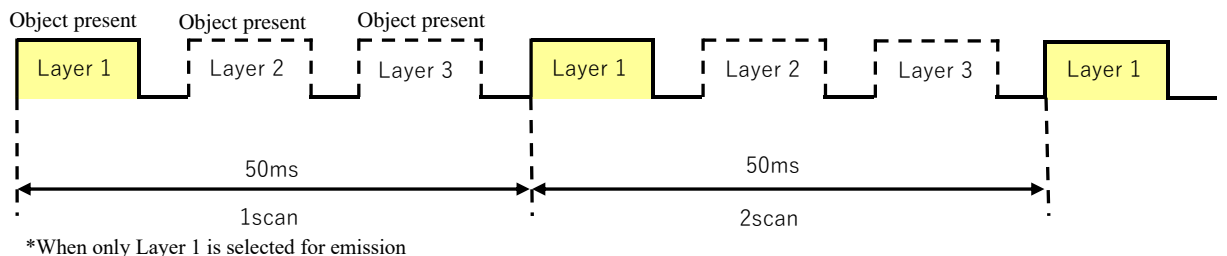

Fig 3-8 Single-layer mode emission image

3.5 Area Configuration

By switching to LA mode, the area-detection function becomes available. For details on modes, refer to Section 3.13. You can set up to two areas by changing the input settings. Each area can contain up to five regions assigned to each of the three layers. Note that outputs are shared across layers. For example, if an object enters Region 1 on Layer 1, Layer 2, or Layer 3, Output 1 will activate.

Each setting can be configured using the Area Designer Prime application via Ethernet communication. When an object enters a configured region, the corresponding detection output signal changes from ON to OFF.

Table 3-1 Relationship between Inputs, Areas, Layers, and Regions

Input 1	Area Number	Layer	Region
ON	Area 0	Layer 1	Region 1
			Region 2
			Region 3
			Region 4
			Region 5
		Layer 2	Region 1
			Region 2
			Region 3
			Region 4
			Region 5
		Layer 3	Region 1
			Region 2
			Region 3
			Region 4
			Region 5
OFF	Area 1	Layer 1	Region 1
			Region 2
			Region 3
			Region 4
			Region 5
		Layer 2	Region 1
			Region 2
			Region 3
			Region 4
			Region 5
		Layer 3	Region 1
			Region 2
			Region 3
			Region 4
			Region 5

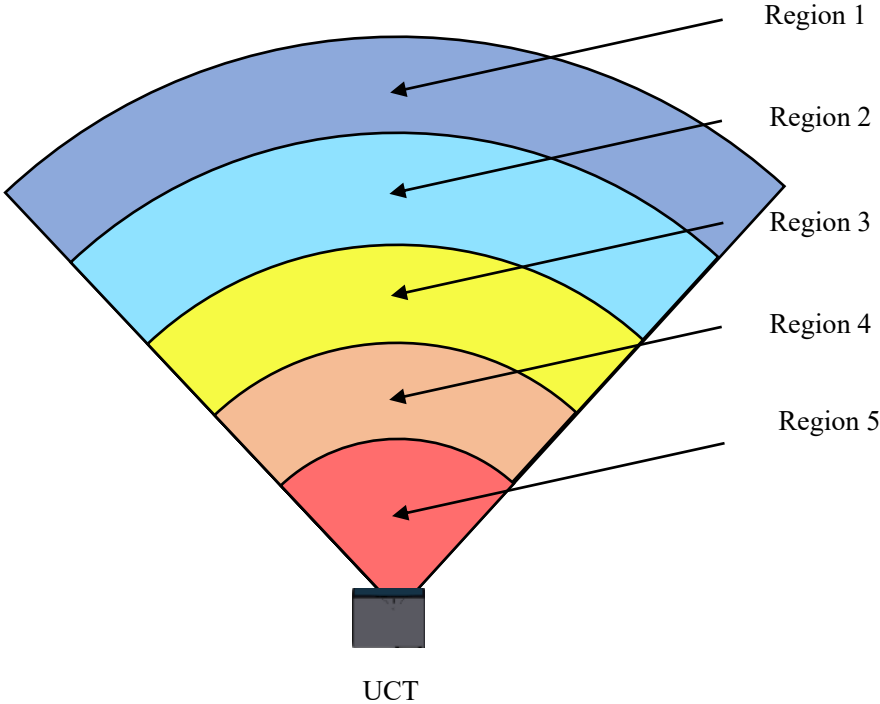

Fig 3-9 UCT detection areas

The possible detection area types of UCT are shown in Figure 3-9. The detection area of UCT consists of output regions: Outputs 1 through 5. There are two configuration methods: independent and dependent. For independent shapes, polygons, arcs, and rectangles are available, and each region can be freely configured. It is also possible to combine independent and dependent shapes.

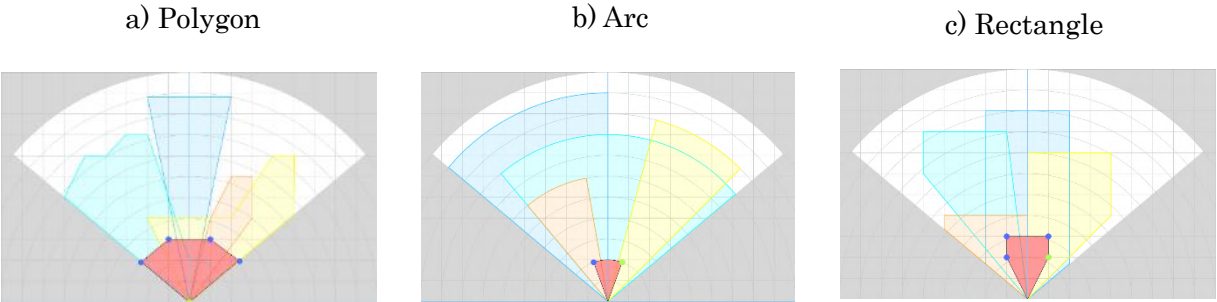

Fig 3-10 Area setting (Independent setting)

For the dependent method, the following shapes are defined: Straight line, Fan, and Ratio. Region 1 serves as the basis for region 2. Similarly, region 2 can be set as the basis for region 3.

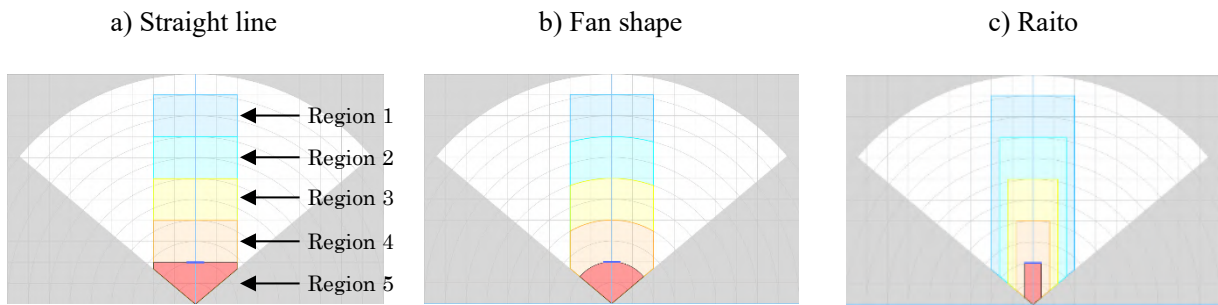

Fig 3-11 Area setting (dependent setting)

When setting the region 2 as dependent on region 1, the following dependent methods can be selected: a) Straight line, b) Fan shape, c) Ratio. Moving the offset bar along the Y-axis changes the size of the region. Each region can be configured based on the preceding region, but it cannot be larger than the previous region (for example, Region 2 is generated based on the shape of region 1 and cannot be created larger than Region 1). For details on the configuration methods, please refer to the *Area Designer Prime* Instruction Manual (C-41-02680). When the sensor detects an object in the configured Regions 1 through 5, the corresponding output signals are switched to the OFF state, and the corresponding LEDs light up.



- Before use, the user should verify the configured detection areas using a test piece.

3.6 Relationship between Layers, Regions, and Outputs

3.6.1 Outputs in Multi-layer Mode

Basically, in multi-layer mode, output evaluation is performed every 16.7 ms, but the evaluation conditions vary depending on the region configuration.

- ① When regions are assigned to all layers
Output evaluation is performed for each layer. The response speed is 16.7ms.
- ② When layers with and without regions are mixed
Output evaluation is performed only on layers with regions. Layers without regions hold the previous output.
- ③ When no region is assigned to any layers, output evaluation is not performed and the output remains ON.

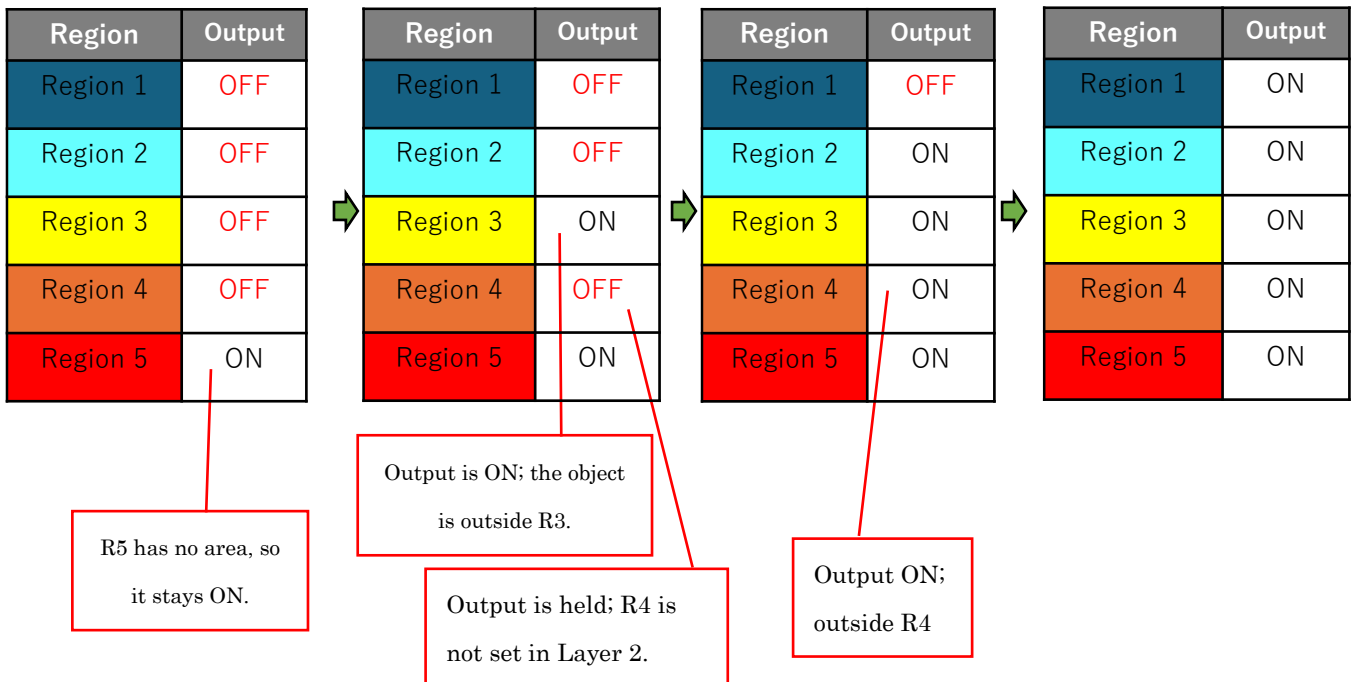
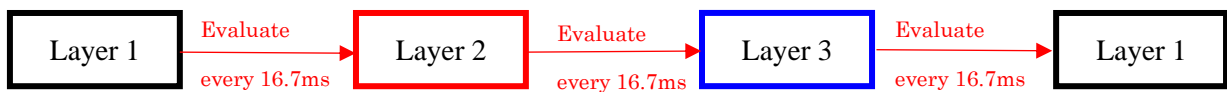
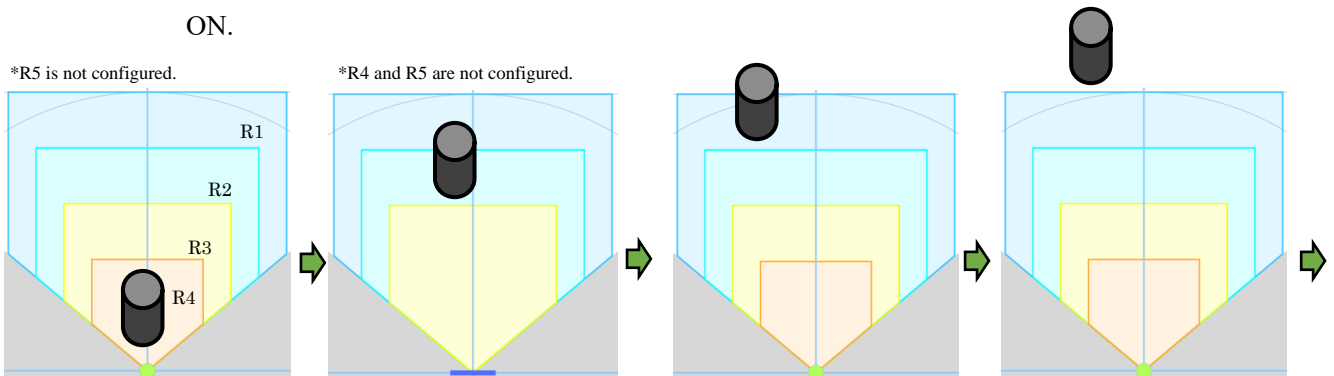

Fig 3-12 Example of Outputs in Multi-layer Mode

●Precautions When Using Multi-layer Mode

Because Layers 1, 2, and 3 are angled vertically, their final detectable distances differ even when regions are set to the same distance. As a result, when identical regions are used in multi-layer mode, chattering may occur between layers when detection happens at the region edges.

Chattering between layers can be avoided by using hysteresis or delay functions. Additionally, if vertical multi-layer detection is not required, consider operating in single-layer mode.

■ Without Hysteresis

Side view of the sensor
When Region 2 is drawn at equal distances in Layers 1–3, Layers 2 and 3 are positioned closer to the sensor than the detected object.

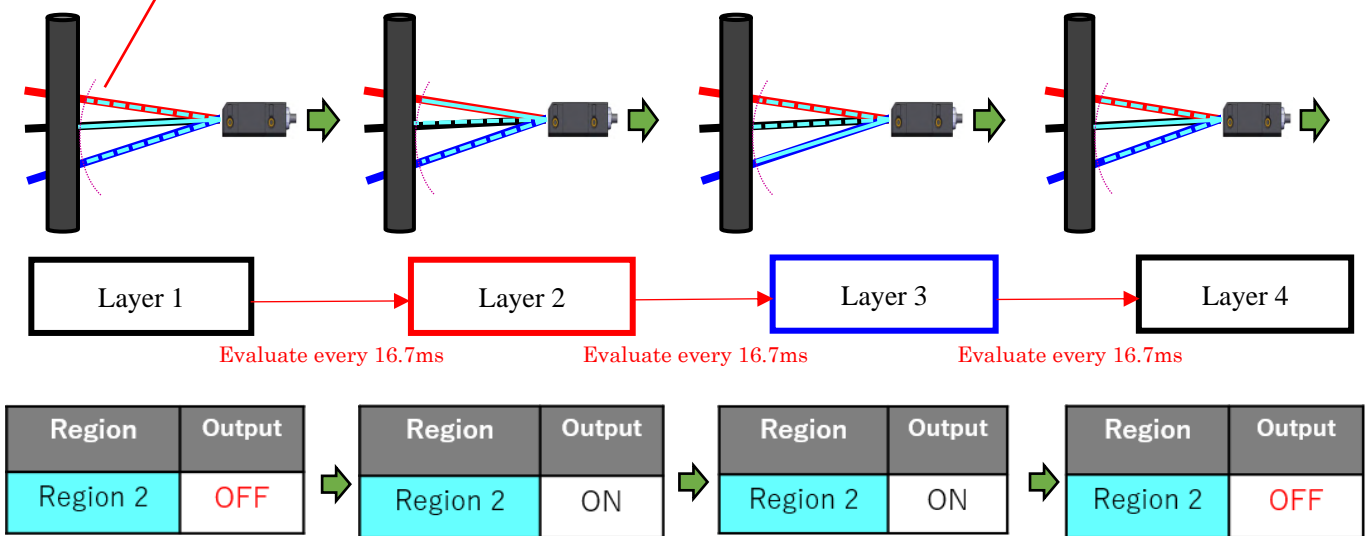

■ With Hysteresis ON

Because Layer 1 turned OFF, Layer 2 enters the hysteresis area and also turns OFF (the same applies to Layer 3).

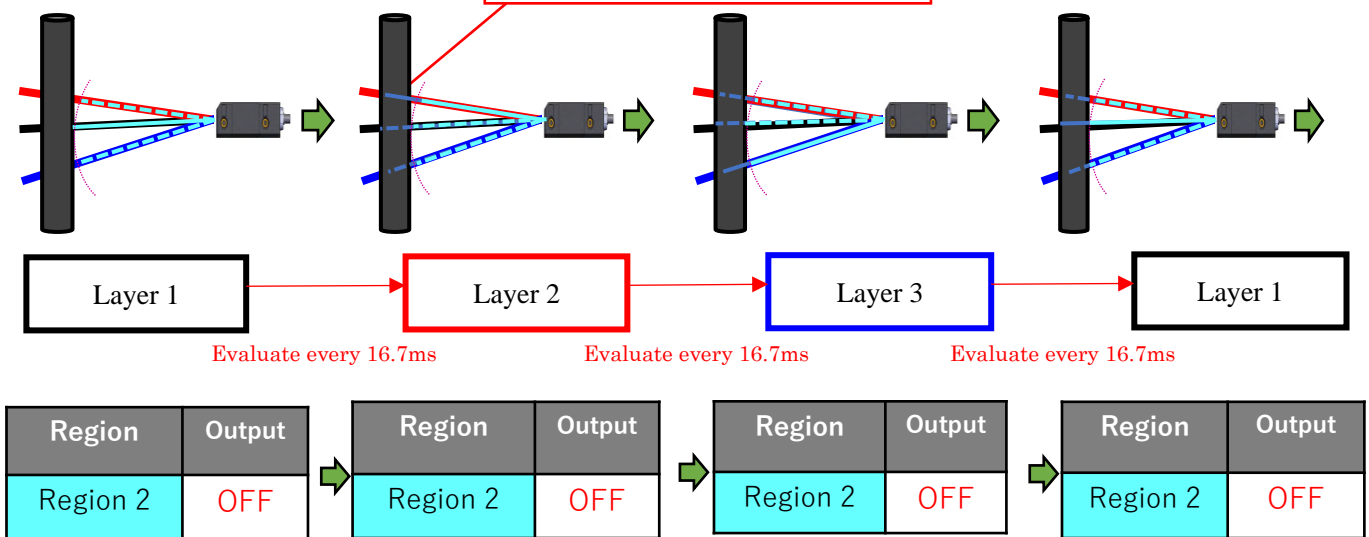

Fig 3-13 Precautions When Using Multi-layer Mode

● Example of Using Multi-layer Mode

The multi-layer mode can be used for detecting steps and for recognizing a wider area using all three layers..

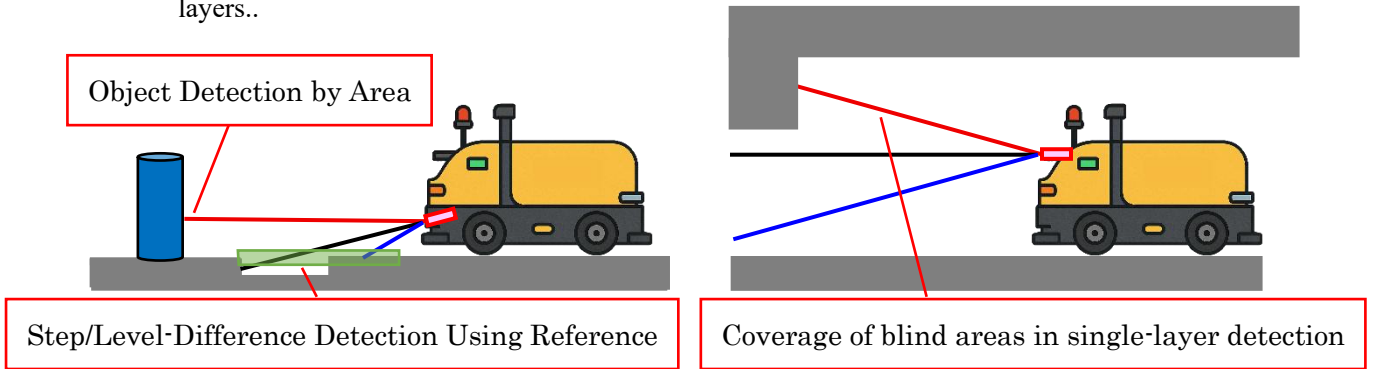

Fig 3-14 Example of Using Multi-layer Mode

3.6.2 Outputs in Single-layer Mode

In the single-layer mode, emission and output evaluation are performed only in the one selected layer out of the three. During the non-selected layers, the output from the selected layer is maintained.

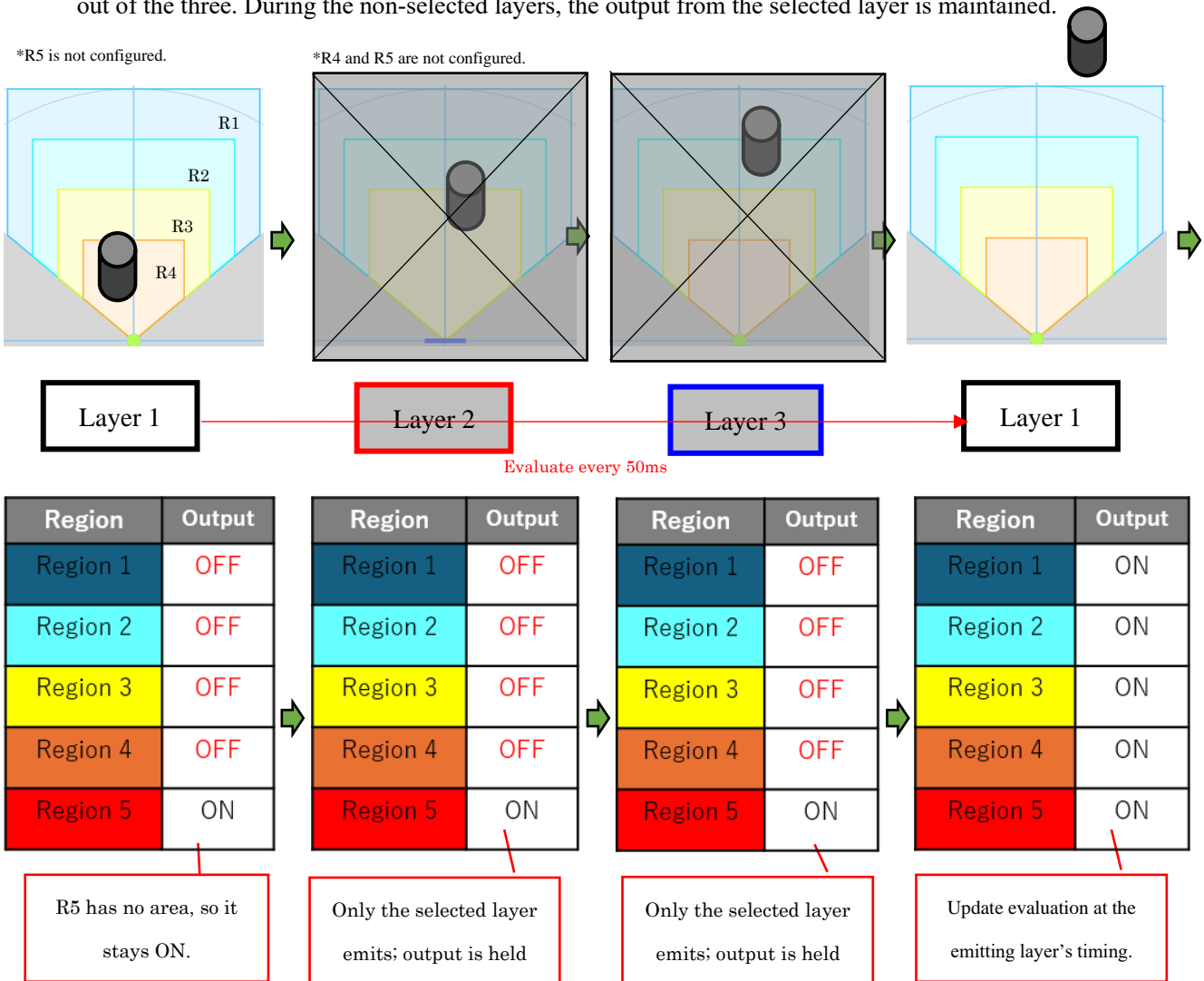

Fig 3-15 Example of Outputs in Multi-layer Mode

Note

- If no region is assigned to an area, that area becomes a non-emission area.
- In the multi-layer mode, if a region is set on one layer, other layers will also emit.

3.7 Area Switching

UCT-10LCM can register up to two areas. Switching between areas requires an input signal. With the input ON, it switches to Area 0, and with the input OFF, it switches to Area 1.

Note: OFF: High level or OPEN, ON: Low level

3.8 Detection Condition

In the configured area, if the detectable size (width) is greater than the minimum detectable object size, an output signal is generated (for setting, refer to Section 3.13). The width of the detectable object can be calculated as shown in Figure 3-16.

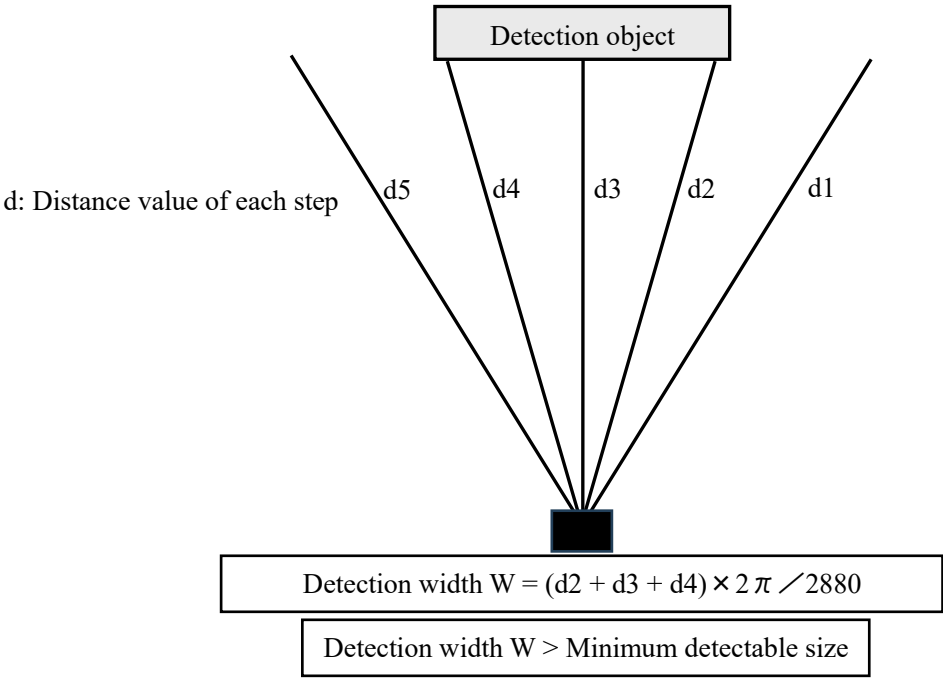

Fig 3-16 Schematic diagrams for the calculation of detection width

If a region is configured with a width narrower than the minimum detectable object width, please note that the output signal may not be generated at close range, as shown in Figure 3-17.

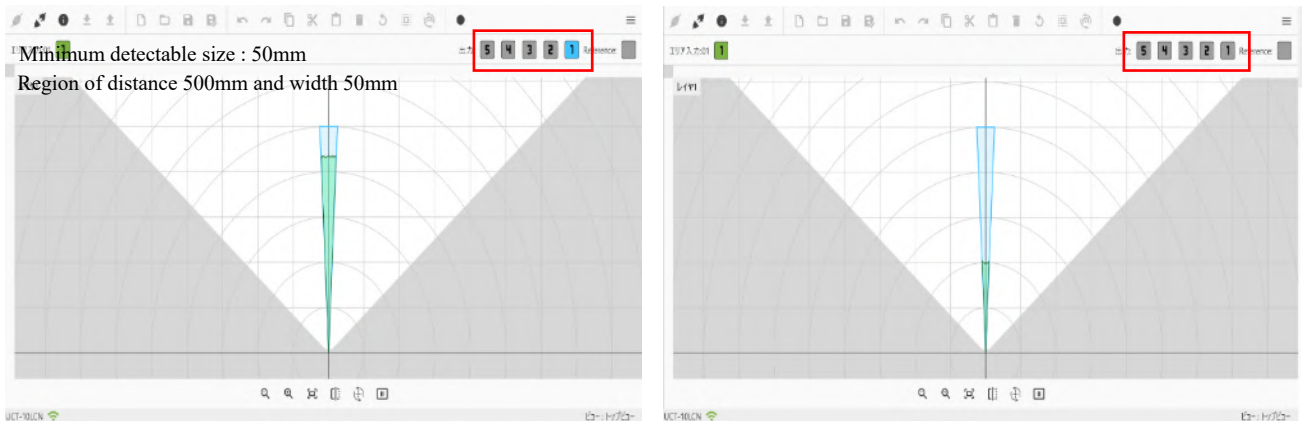

Fig 3-17 Caution of area configurations when minimum detectable size



Caution

- Depending upon the laser spot, environment and detection object, the actual width of detected objects may differ from the width measured.
- Depending upon the laser spot, environment and detection object, the actual width of detected objects may differ from the width measured.

3.9 ON/OFF delay

The ON/OFF Delay function delays the detection output delayed when the sensor detects an object within a region. This function is effective for reducing chattering and similar phenomena.

The ON/OFF Delay can be configured using Area Designer Prime. In the single layer mode, it can be set within the range of 1scan (70ms)~128 scans(6420ms). In multi-layer mode, it can be set within the range of 1 scan (37 ms) to 128 scans (2158 ms). The factory default value is 1 scan.

The ON delay is the response time required for the output to change from the OFF state to the ON state. The OFF delay is the response time required for the output to change from the ON state to the OFF state.

Increasing the response time will increase availability of UCT. However, this will reduce its ability to detect moving objects. Users must perform verification tests before using the ON/OFF delay function. The ON delay and OFF delay can be configured individually for each region.

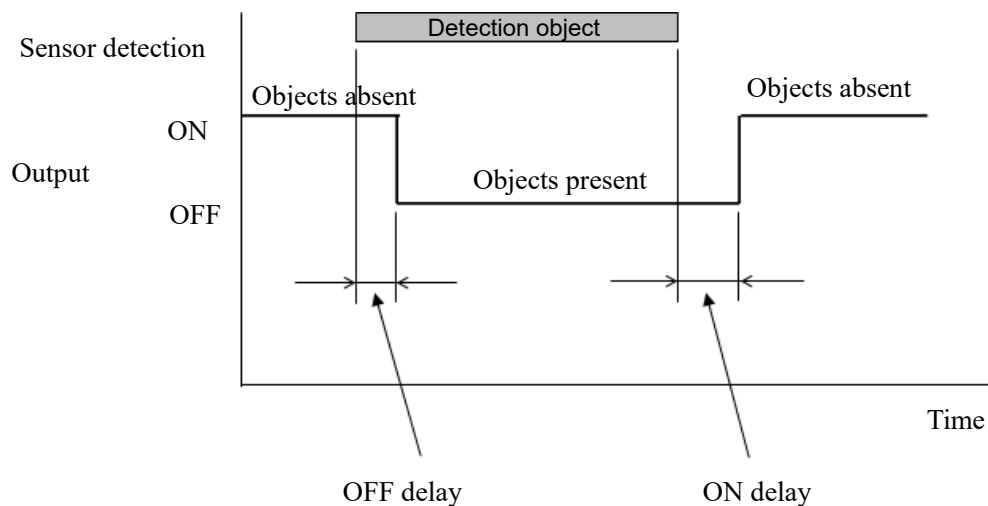

Fig 3-18 ON delay /OFF delay

Schematic diagram for ON delay/OFF delay operation is as shown below.

(I) Multi-Layer: Conceptual Operation Diagram without OFF Delay

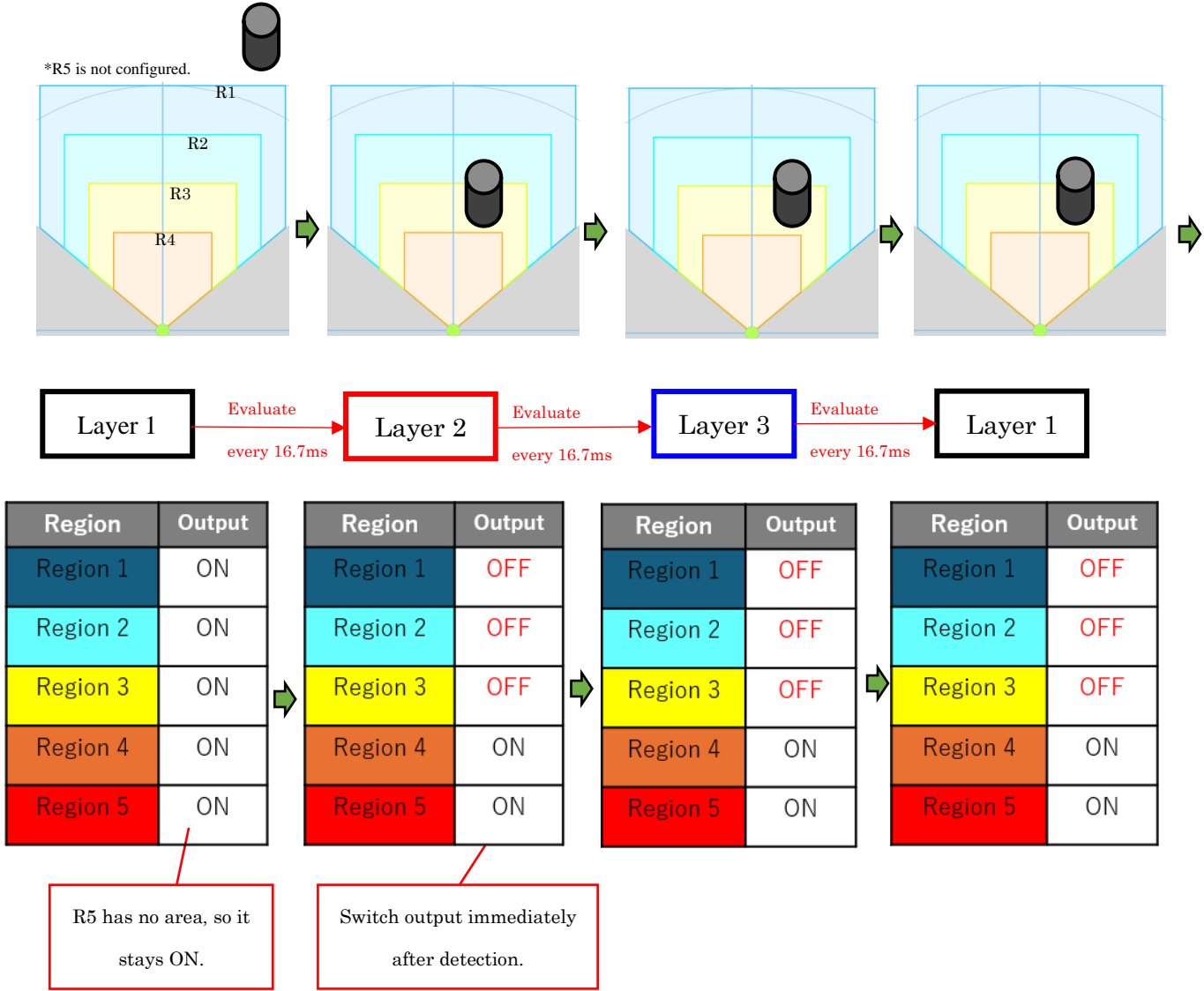

Fig 3-19 Output example of multi-layer mode without OFF delay

(II) Multi-Layer: Conceptual Operation Diagram with OFF Delay set to 2 Scans

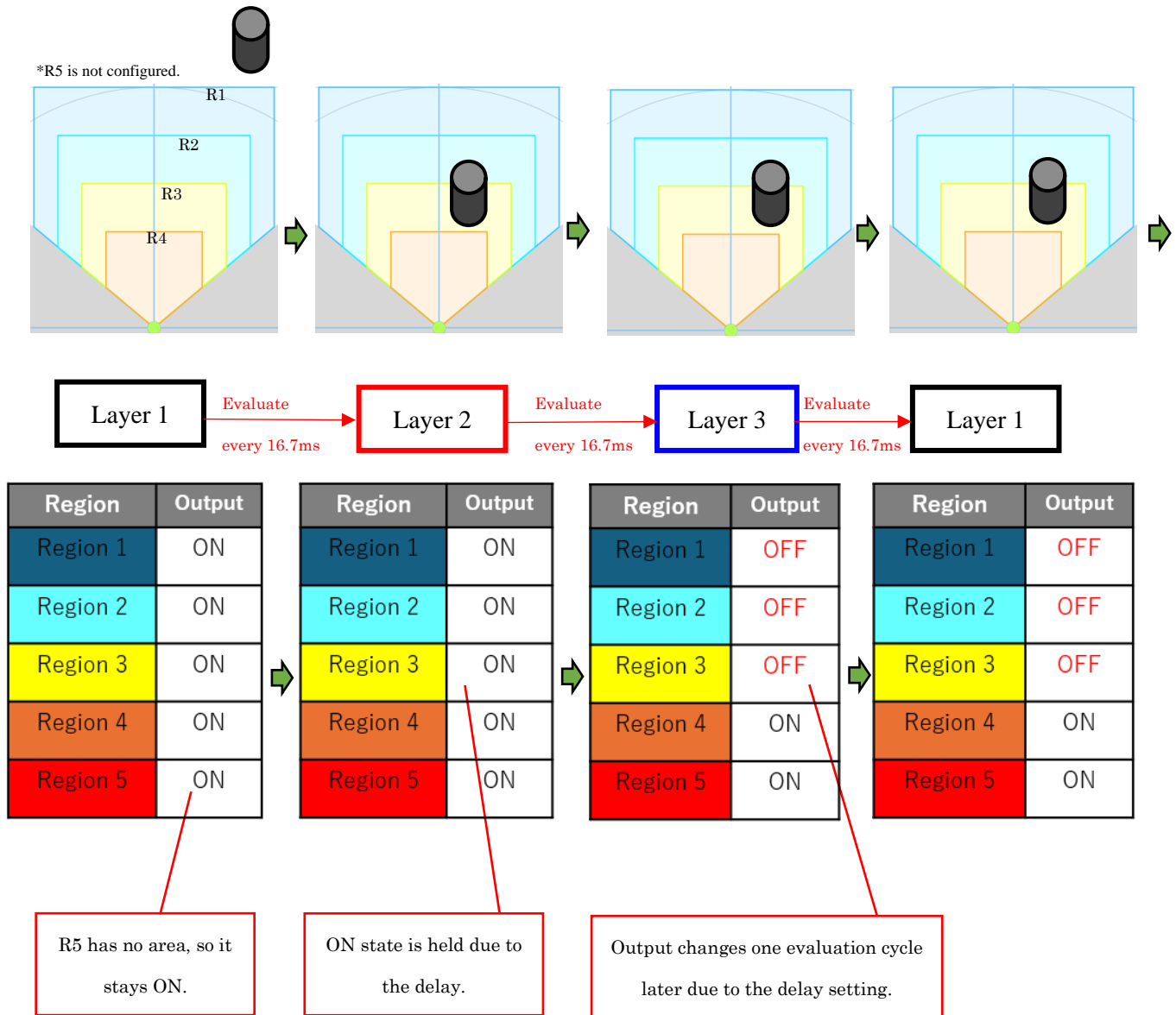

Fig 3-20 Output example of multi-layer mode with OFF delay “2”

(III) Single-Layer: Conceptual Operation Diagram without OFF Delay

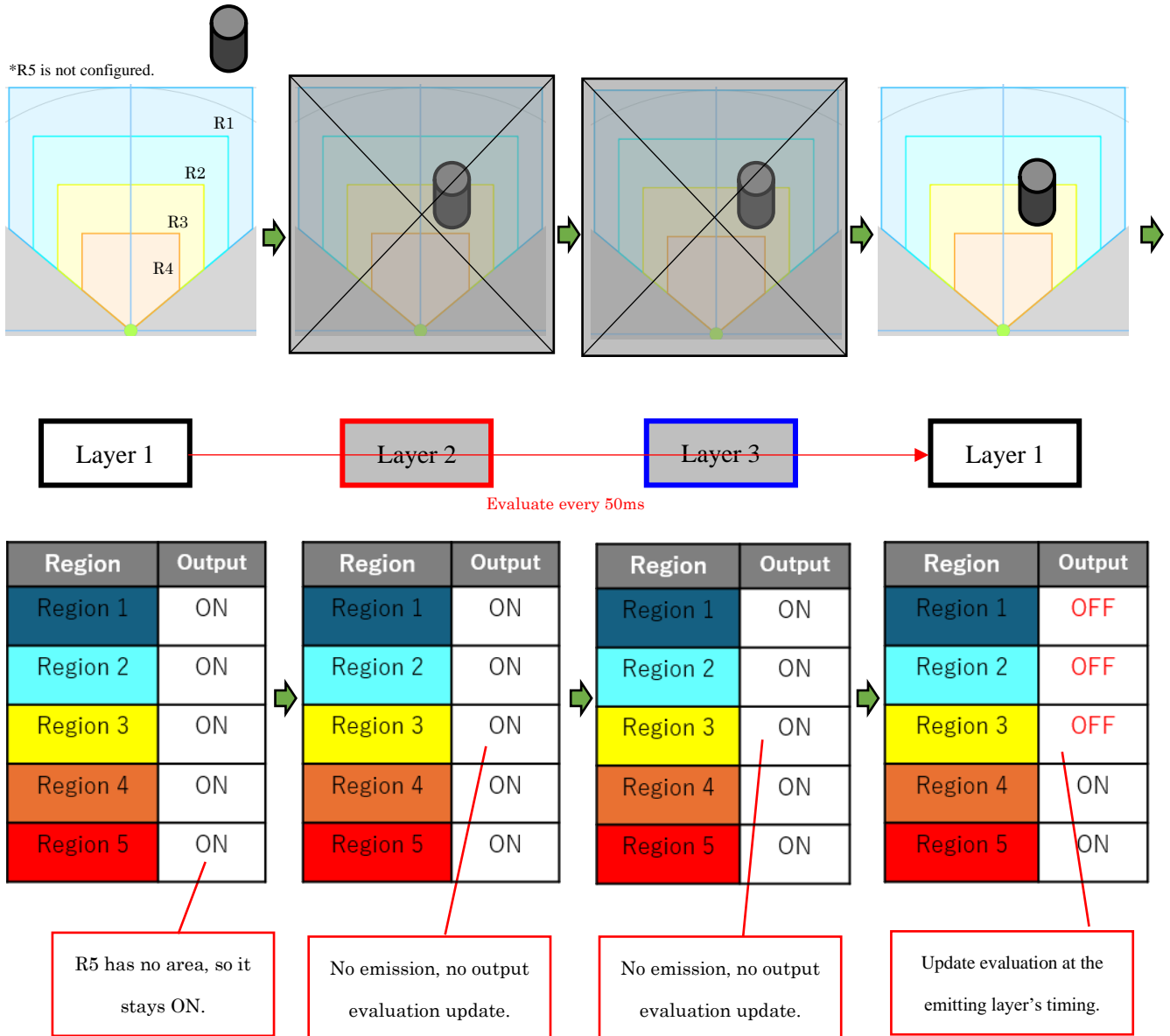
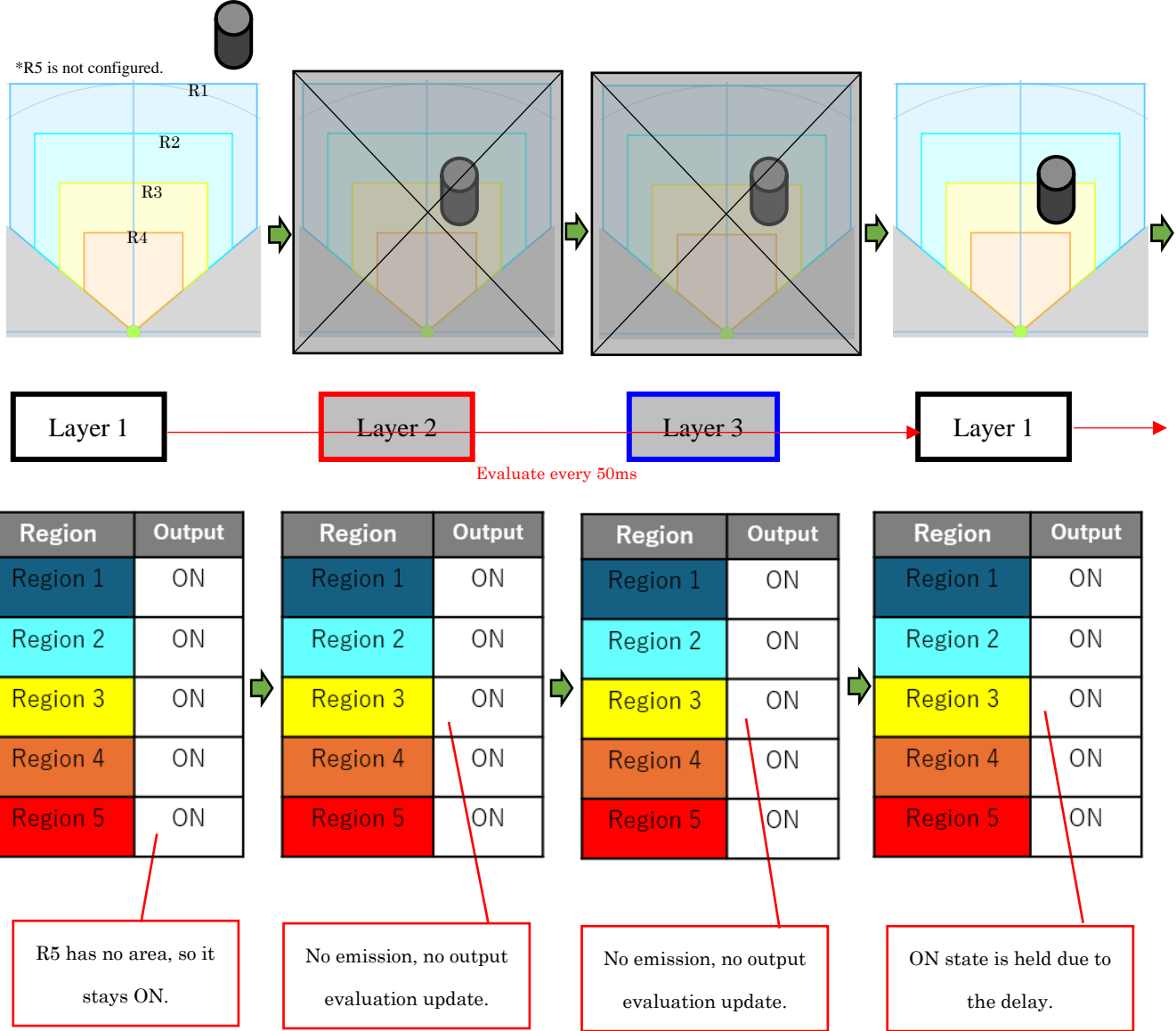

Fig 3-21 Output example of single-layer mode without OFF delay

(IV) Sigle-Layer: Conceptual Operation Diagram with OFF Delay Set to 2 Scans



continued

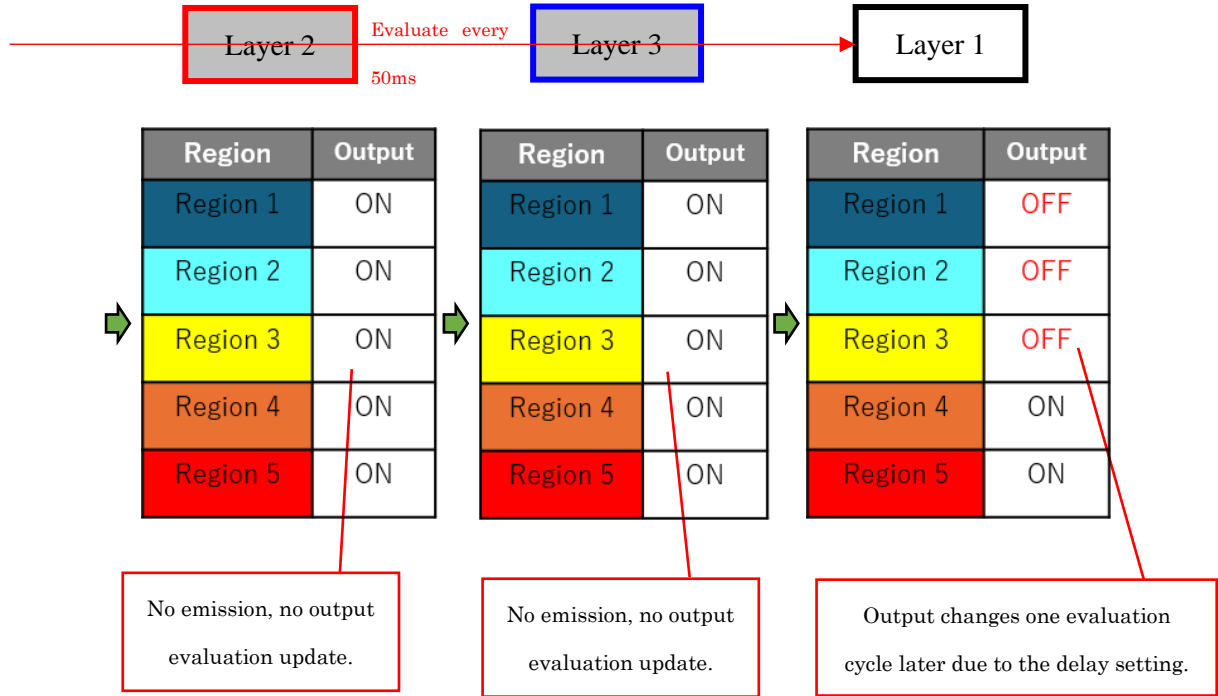
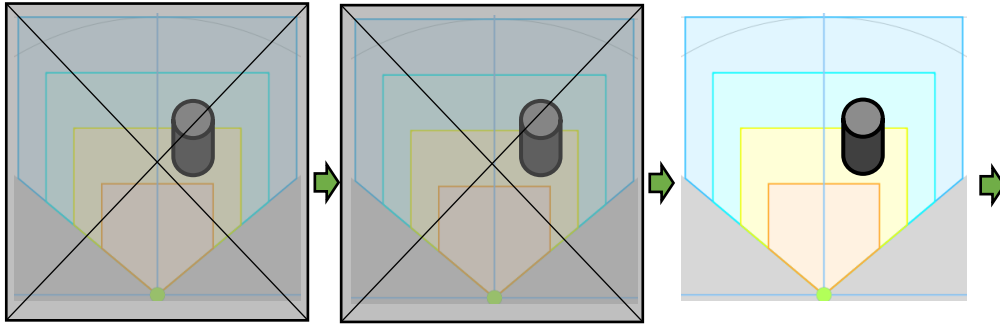

Fig 3-22 Output example of single-layer mode with OFF delay “2”

(V) Multi-Layer: Conceptual Operation Diagram without On Delay Set to 2 Scans



Fig 3-23 Output example of multi-layer mode without ON delay

(VI) Multi-Layer: Conceptual Operation Diagram with On Delay Set to 2 Scans

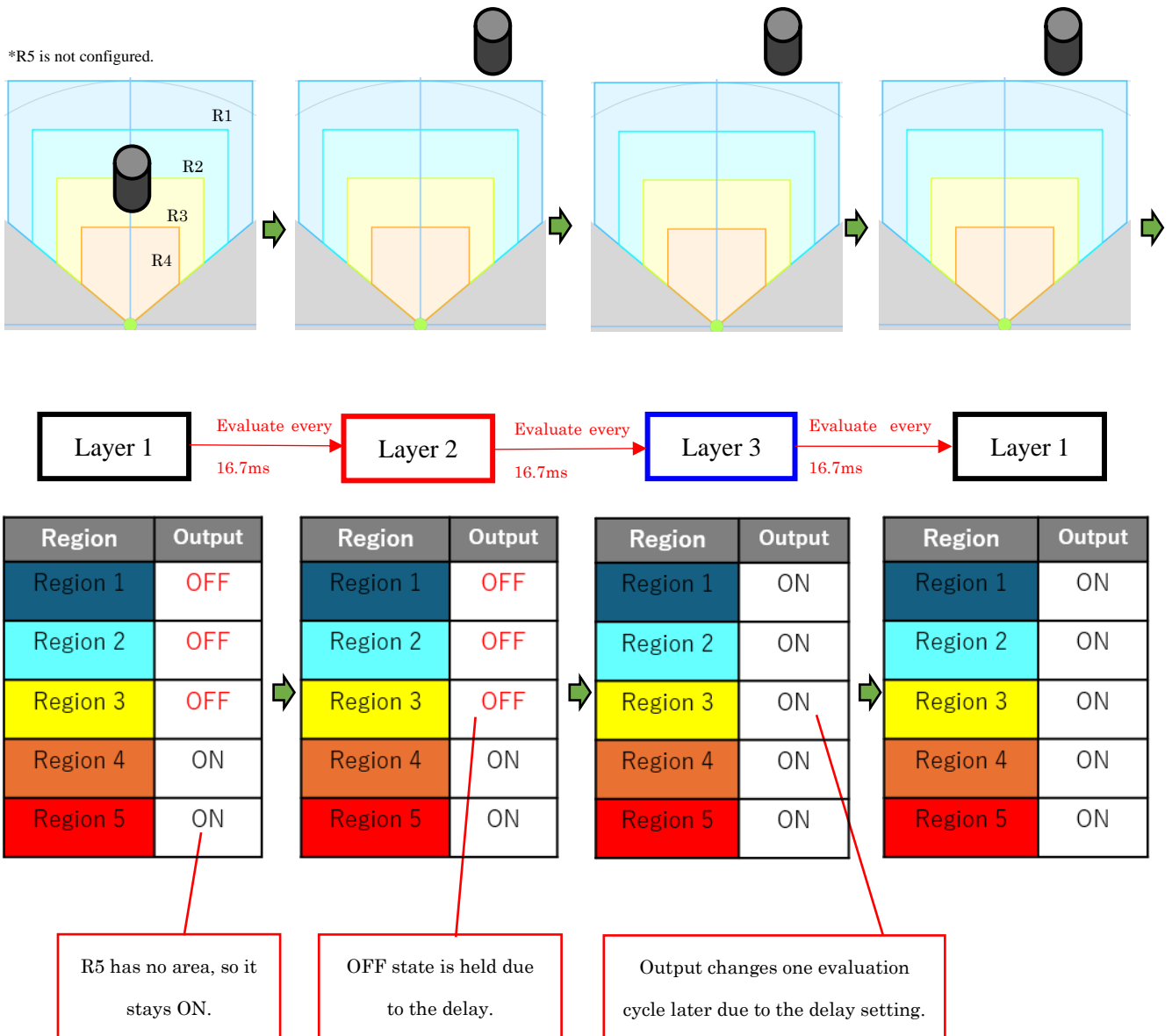

Fig 3-24 Output example of multi-layer mode with ON delay “2”

(VII) Single Layer: Conceptual Operation Diagram without On Delay

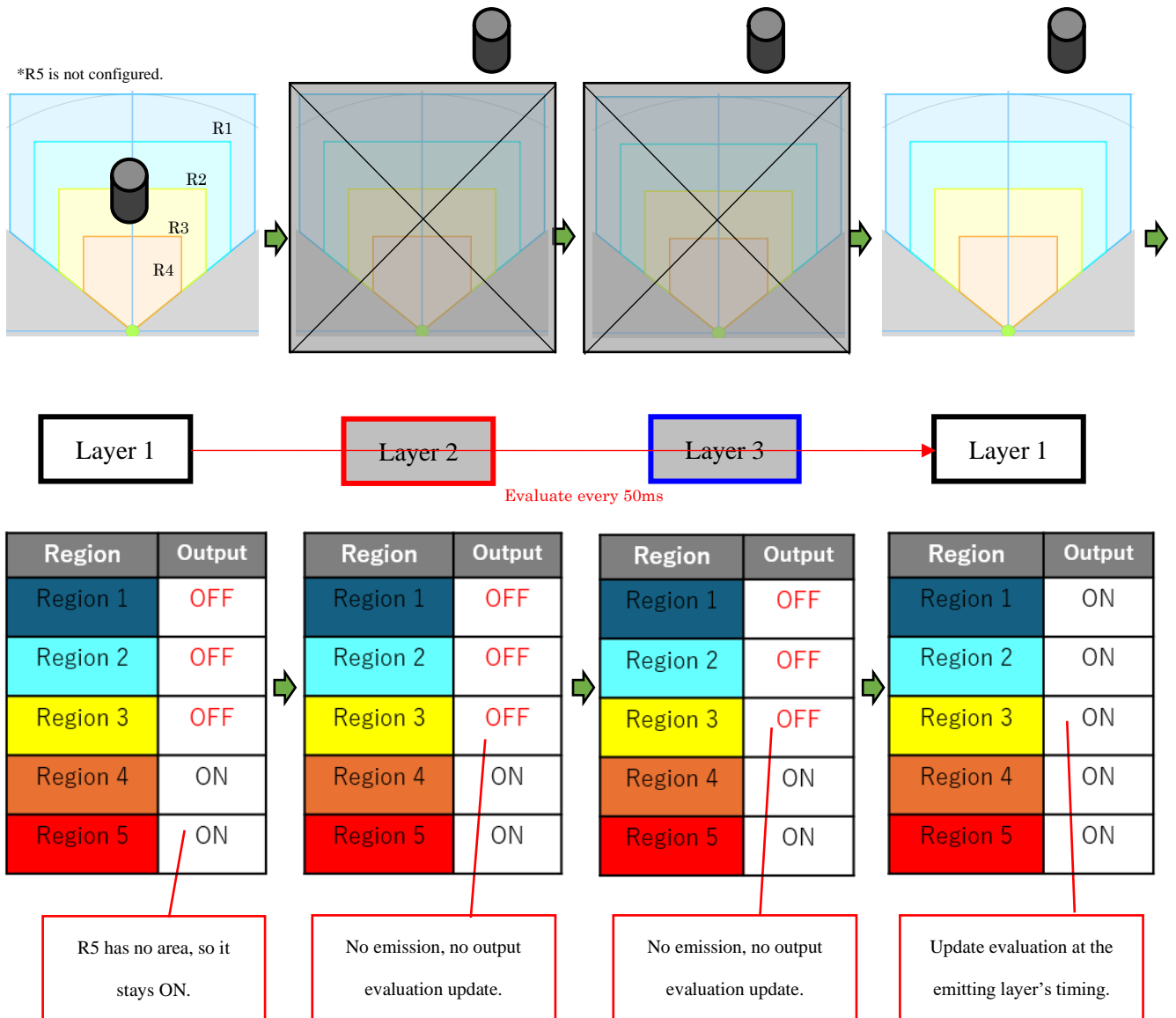
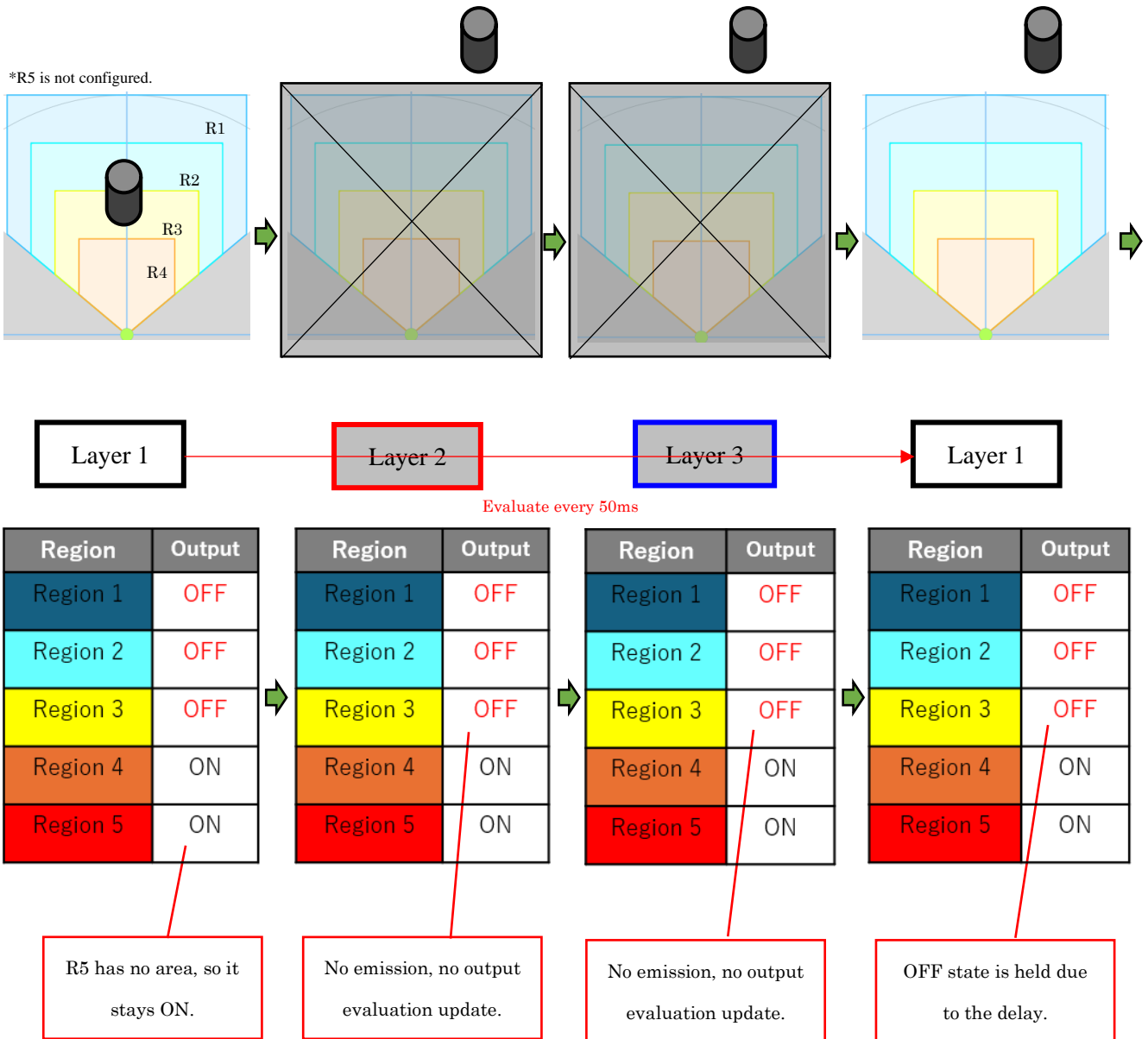

Fig 3-25 Output example of single-layer mode without ON delay

(VIII) Single Layer: Conceptual Operation Diagram with On Delay Set to 2 Scans



continued

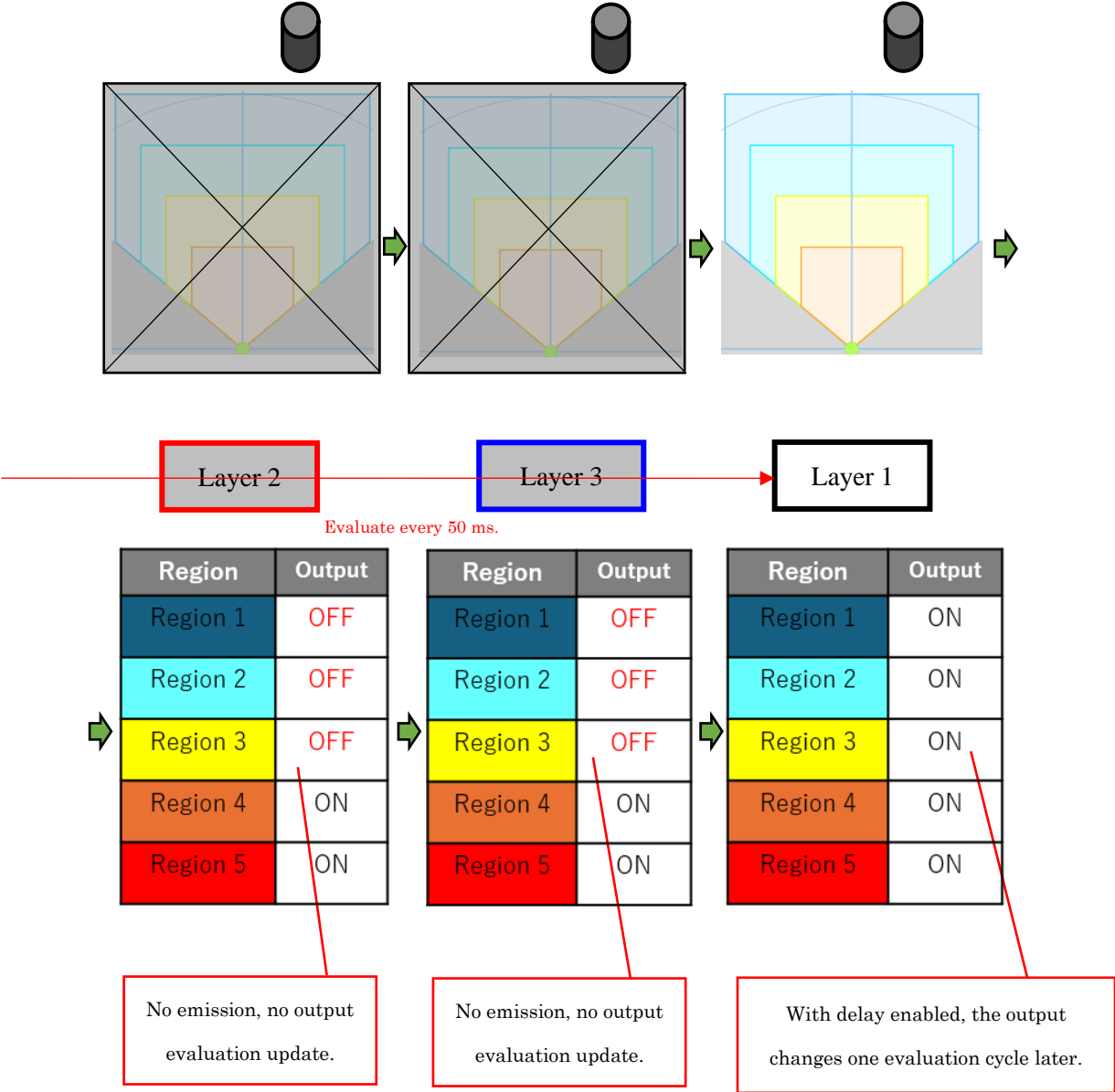

Fig 3-26 Output example of single-layer mode with ON delay “2”

3.10 Hysteresis Function of Detection Area

When a sensor detects an object near the boundary of a detection area, the detection outputs 1 to 5 may oscillate between ON and OFF.

To prevent this, the sensor has a hysteresis function that temporarily expands the detection area by a specified ratio when an object is detected within the area.

If the object is no longer detected within the expanded area, the detection area returns to its original setting.

The hysteresis setting can be applied either per area or per region.

Three options are available for the setting: None (0%), Low (3.125% increase over the area setting), and High (6.25% increase over the area setting).

Figure 3-27 shows an example of its operation.

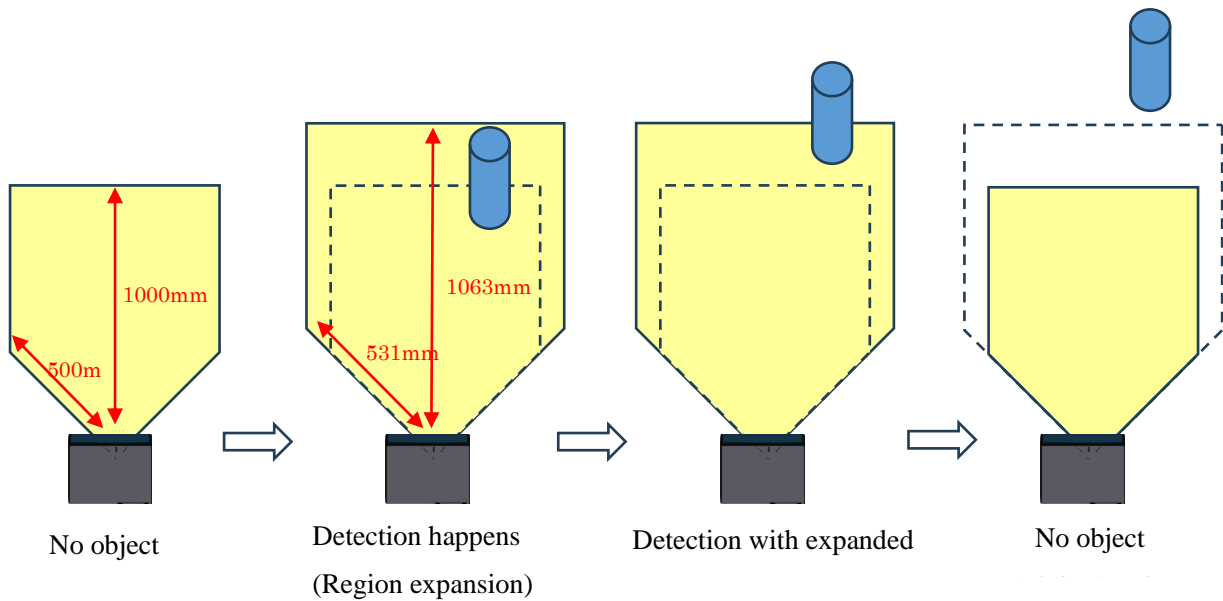
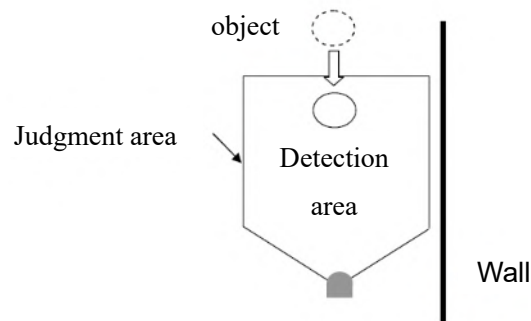

Fig 3-27 Example of a detection behavior with High (6.25%) value

Note

- When you set the detection area close to a wall, set the hysteresis to the minimum value. If the surface of the wall falls within the hysteresis-extended detecting area, the output will not return to its original state.
 - Judgment Area : From object absent to object present



- Judgment Area : From object present to object absent

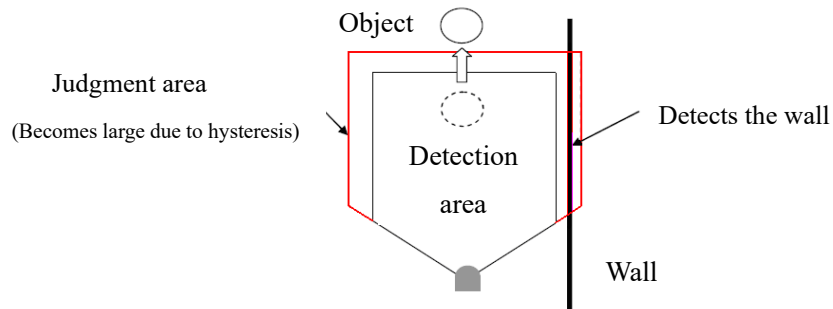

3.11 Scan Skip Function

When the scan skip function is activated, it stops laser emission for the specified number of scan during operation of the set scan number during rotation. Through sensor setting, laser emission can be stopped for 0 to 5 scans. Figure 3-28 shows a schematic diagram, when the scan-skip count is set to “0”. When “0” is set, the scan-skip function will become inactive and performs normal operation.

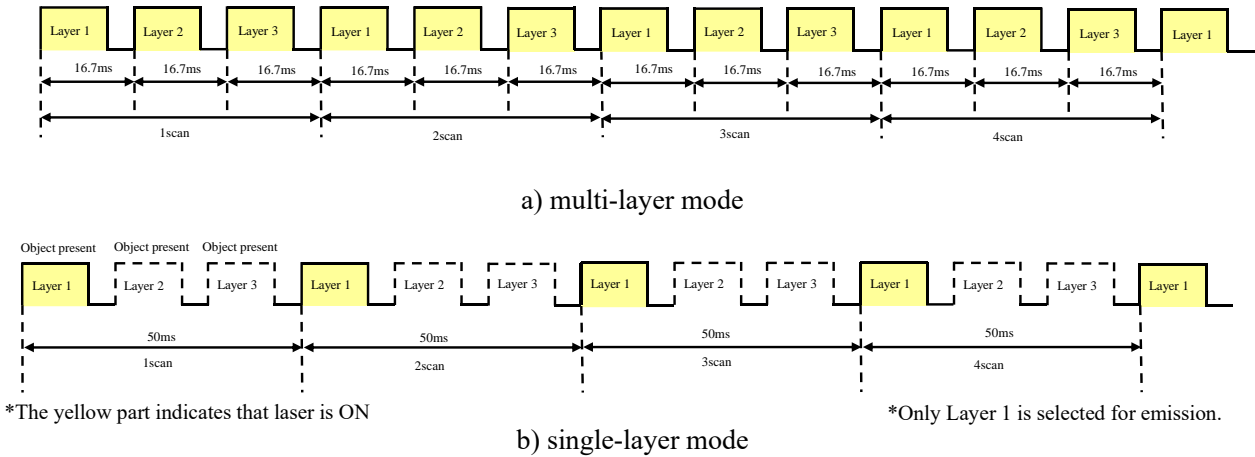

Fig 3-28 Schematic diagram when scan skip count “0” is set

Figure 3-29 shows a schematic diagram, when the scan-skip count “2” is set. When “2” is set, the sensor stops laser emission for 2 scans. During scan skips, the output state remains the same as during the laser emission period.

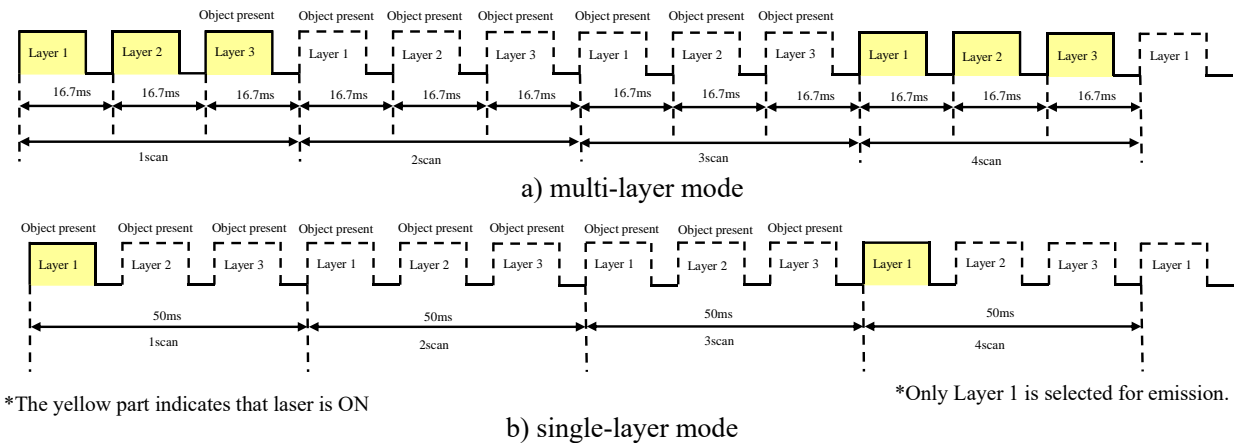

Fig 3-29 Schematic diagram when scan skip count “2” is set

The maximum response time can be calculated “70ms +(50ms × Scan skip count)”. In the case of 2 scan skip, calculation will be “70ms +(25ms × 2) = 170ms”. *In single-layer mode.

Caution ● When the scan skip function is enabled, the ON delay, OFF delay, and Interference reduction filter are disabled.
*The ON delay and OFF delay display in Area Designer Prime will not change.

Note

- If the laser of UCT affects the other products operation (causes light interference in other products), activate scan skip function to reduce effects on other products.

3.12 Reference Functions

The reference function switches the reference output terminal to OFF when the measured distance deviates from the configured reference region. The allowable tolerance range can be configured.

In addition to Area 0 and Area 1, one reference area can be configured.

Reference areas can be configured using regions on a per-layer basis.

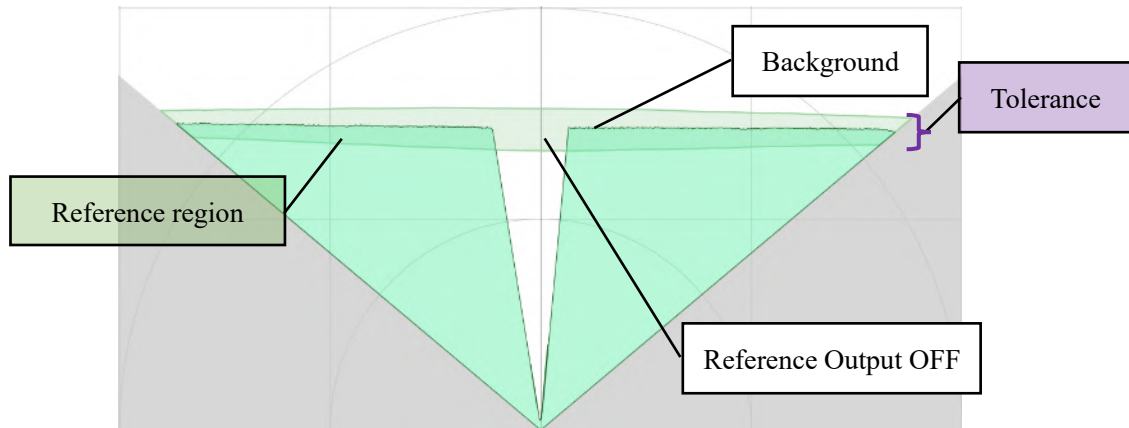

Fig 3-30 Example of Reference Region Detection

There are two methods for configuring reference regions: a manual method using the dedicated application, and an input-switching method in which an area input is assigned as the reference input.

● Configuration Using the Dedicated Application Area Designer Prime

You can connect to the Area Designer Prime and manually write the areas.

For detailed configuration instructions, please refer to the Area Designer Prime manual (C-41-02680).

● Configuration Using Reference Input Function

Enabling “Reference Input” under “Sensor Configuration” in Area Designer Prime assigns the area input as the reference input. In that state, turning the reference input ON for 1 second or longer and then turning it OFF starts automatic reference-area generation based on the current surroundings. During the generation process, the power indicator blinks.

Table-3-2 Configuration and Output via Reference Input

Input 1	Area	Reference Output	Detection Output
OFF	Area 1	Judged by the generated region	Output according to the region of Area 1
ON		Judged by the generated region	
ON(1s)→OFF		Automatic generation performed Judged by the region after automatic generation	
OFF→ON		Judged by the generated region	

In the following cases, a reference region will not be generated for that step:

- When the measured distance is 10 meters or greater
- When the measured distance fluctuates beyond the allowable tolerance

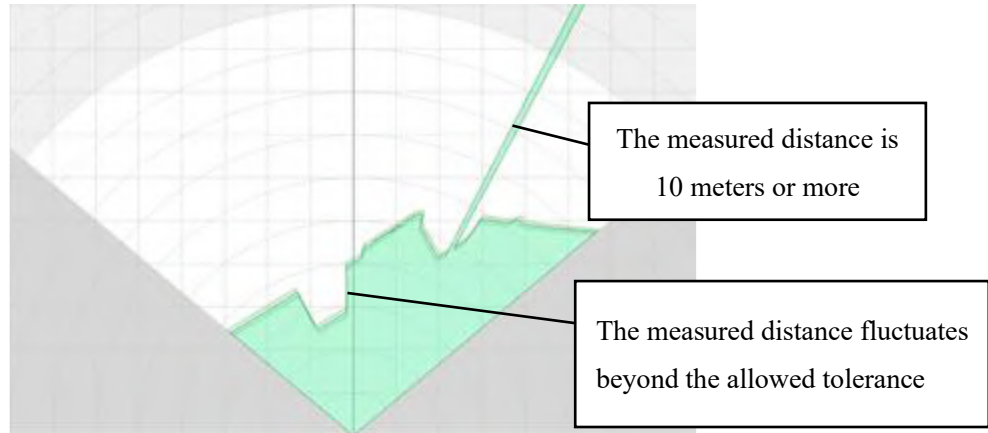

Fig 3-31 Example of Automatic Reference Region Generation



Caution

- When the reference input function is enabled, Area 0 becomes unavailable. Even if the input is switched, the sensor operates only in Area 1.

3.13 Setting of UCT

Setting of operating parameters of UCT by Area Designer Prime.

Table 3-3 describes UCT's parameters and settings.

Table 3-3 Parameter setting

Parameter	Description						
Outputs logic Inversion *1	<p>Output inversion can be configured for both the area output and the reference output (malfunction outputs will not be inverted). Select from the settings below.</p> <table border="1"> <thead> <tr> <th>Setting</th> <th>Description</th> </tr> </thead> <tbody> <tr> <td>OFF [default]</td> <td>Refer to section 3.14.</td> </tr> <tr> <td>ON</td> <td>Invert outputs</td> </tr> </tbody> </table>	Setting	Description	OFF [default]	Refer to section 3.14.	ON	Invert outputs
Setting	Description						
OFF [default]	Refer to section 3.14.						
ON	Invert outputs						
Reference Input *1	<p>Select whether the area input is assigned as the reference input. With reference input turned ON, area switching is disabled, and the detection area is fixed to Area 1. Input signal is used as the trigger for automatic reference area generation. *Turning it ON for 1second and then OFF automatically generates the reference area.</p> <table border="1"> <thead> <tr> <th>Setting</th> <th>Description</th> </tr> </thead> <tbody> <tr> <td>Disable [default]</td> <td>Input 1 is used as the area selection input.</td> </tr> <tr> <td>Enable</td> <td>Input 1 is assigned as the reference input. See Section 3.12.</td> </tr> </tbody> </table>	Setting	Description	Disable [default]	Input 1 is used as the area selection input.	Enable	Input 1 is assigned as the reference input. See Section 3.12.
Setting	Description						
Disable [default]	Input 1 is used as the area selection input.						
Enable	Input 1 is assigned as the reference input. See Section 3.12.						
Mode selection	<p>Select the operation mode.</p> <table border="1"> <thead> <tr> <th>Setting</th> <th>Description</th> </tr> </thead> <tbody> <tr> <td>LX Mode</td> <td>Data output type. Supports multi-echo data output. It is not possible to use the detection outputs.</td> </tr> <tr> <td>LA Mode [default]</td> <td>Area detection and data output type. It is a single echo data output.</td> </tr> </tbody> </table> <p>Note: The sensor will restart when the mode selection is changed.</p>	Setting	Description	LX Mode	Data output type. Supports multi-echo data output. It is not possible to use the detection outputs.	LA Mode [default]	Area detection and data output type. It is a single echo data output.
Setting	Description						
LX Mode	Data output type. Supports multi-echo data output. It is not possible to use the detection outputs.						
LA Mode [default]	Area detection and data output type. It is a single echo data output.						

パラメータ名称	説明										
UDP's target IP address	<p>When using UDP communication, the IP address to which UCT sends data can be configured.</p> <table border="1" data-bbox="587 333 1331 383"> <tr> <td>[default]</td> <td>192.168.0.100</td> </tr> </table>	[default]	192.168.0.100								
[default]	192.168.0.100										
Measurement	<p>You can select which layer emits light. For more details, refer to Section 3.4.</p> <table border="1" data-bbox="587 533 1331 969"> <thead> <tr> <th>Setting</th> <th>Description</th> </tr> </thead> <tbody> <tr> <td>All Layers [default]</td> <td>Layers 1, 2, and 3 all emit light. (Multi-layer mode)</td> </tr> <tr> <td>Layer 1</td> <td>Only Layer 1 (center layer) emits light. (Single-layer mode)</td> </tr> <tr> <td>Layer 2</td> <td>Only Layer 2 (upper layer) emits light. (Single-layer mode)</td> </tr> <tr> <td>Layer 3</td> <td>Only Layer 3 (lower layer) emits light. (Single-layer mode)</td> </tr> </tbody> </table>	Setting	Description	All Layers [default]	Layers 1, 2, and 3 all emit light. (Multi-layer mode)	Layer 1	Only Layer 1 (center layer) emits light. (Single-layer mode)	Layer 2	Only Layer 2 (upper layer) emits light. (Single-layer mode)	Layer 3	Only Layer 3 (lower layer) emits light. (Single-layer mode)
Setting	Description										
All Layers [default]	Layers 1, 2, and 3 all emit light. (Multi-layer mode)										
Layer 1	Only Layer 1 (center layer) emits light. (Single-layer mode)										
Layer 2	Only Layer 2 (upper layer) emits light. (Single-layer mode)										
Layer 3	Only Layer 3 (lower layer) emits light. (Single-layer mode)										
Rain filter *1	<p>This filter is used to remove if the object is not detected continuously at the same step within the area. This filter is effective to remove rain detection. It is not supported in LX mode. Select from the settings below.</p> <table border="1" data-bbox="600 1126 1318 1373"> <thead> <tr> <th>Setting</th> <th>Reference value while using rain filter</th> </tr> </thead> <tbody> <tr> <td>OFF [default]</td> <td>Filter is not active.</td> </tr> <tr> <td>Low</td> <td rowspan="2">Used to remove the effect of rain with maximum speed up to approx.100 mm/h. However, the effect depends upon the installation environment</td> </tr> <tr> <td>High</td> </tr> </tbody> </table> <p>Caution: When the rain filter is active, the device becomes less sensitive to detecting moving object.</p>	Setting	Reference value while using rain filter	OFF [default]	Filter is not active.	Low	Used to remove the effect of rain with maximum speed up to approx.100 mm/h. However, the effect depends upon the installation environment	High			
Setting	Reference value while using rain filter										
OFF [default]	Filter is not active.										
Low	Used to remove the effect of rain with maximum speed up to approx.100 mm/h. However, the effect depends upon the installation environment										
High											

Parameter	Description														
Interference Reduction mode	<p>This mode is used to reduce interference between sensors. However, the response time becomes slower as shown in the table below.</p> <table border="1" style="margin-left: auto; margin-right: auto;"> <thead> <tr> <th style="text-align: center;">Setting</th> <th style="text-align: center;">Description</th> </tr> </thead> <tbody> <tr> <td style="text-align: center;">OFF [default]</td> <td>Interference reduction mode is not active.</td> </tr> <tr> <td style="text-align: center;">Low</td> <td>Interference reduction mode is active. The response time is increased by 50 ms.</td> </tr> <tr> <td style="text-align: center;">High</td> <td>Interference reduction mode is active. The response time is increased by 100 ms.</td> </tr> </tbody> </table>	Setting	Description	OFF [default]	Interference reduction mode is not active.	Low	Interference reduction mode is active. The response time is increased by 50 ms.	High	Interference reduction mode is active. The response time is increased by 100 ms.						
Setting	Description														
OFF [default]	Interference reduction mode is not active.														
Low	Interference reduction mode is active. The response time is increased by 50 ms.														
High	Interference reduction mode is active. The response time is increased by 100 ms.														
Close Range Sensitivity	<p>This function removes very narrow objects detected within the close-range area (approximately 50–1800 mm) when the sensor is used in environments with dust or other airborne particles. The error distance value is 65531. For details, refer to Section 3.18.</p> <table border="1" style="margin-left: auto; margin-right: auto;"> <thead> <tr> <th style="text-align: center;">Setting</th> <th style="text-align: center;">Description</th> </tr> </thead> <tbody> <tr> <td style="text-align: center;">Normal [default]</td> <td>The close range sensitivity filter is not used.</td> </tr> <tr> <td style="text-align: center;">Low</td> <td>The close-range sensitivity filter is used.</td> </tr> </tbody> </table> <p>Precaution: With the close-range sensitivity set to “low”, detection performance in the close-range area may decrease. Additionally, areas near protruding shapes may be reported as error values.</p>	Setting	Description	Normal [default]	The close range sensitivity filter is not used.	Low	The close-range sensitivity filter is used.								
Setting	Description														
Normal [default]	The close range sensitivity filter is not used.														
Low	The close-range sensitivity filter is used.														
Echo Select *1	<p>The echo filter is used in environments where multiple echoes occur, such as in rain, fog, dust, object edges or transparent objects. The echo filter can be set to “First” or “Last”.</p> <table border="1" style="margin-left: auto; margin-right: auto;"> <thead> <tr> <th style="text-align: center;">Setting</th> </tr> </thead> <tbody> <tr> <td style="text-align: center;">First [default]</td> </tr> <tr> <td style="text-align: center;">Last</td> </tr> </tbody> </table> <p>Filter effect: If there is an obstacle in front of the sensor, such as a cover, select “Last”. This makes it difficult for the sensor to detect the obstacles (cover).</p> <p>Caution: When “Last” is selected, objects smaller than the laser beam size are difficult to detect.</p>	Setting	First [default]	Last											
Setting															
First [default]															
Last															
Scan skip count	<p>Scan skip count can be set. Select from the settings below.</p> <table border="1" style="margin-left: auto; margin-right: auto;"> <thead> <tr> <th style="text-align: center;">Setting</th> <th style="text-align: center;">Description</th> </tr> </thead> <tbody> <tr> <td style="text-align: center;">0[default]</td> <td>No scan skip.</td> </tr> <tr> <td style="text-align: center;">1</td> <td>1 scan skip.</td> </tr> <tr> <td style="text-align: center;">2</td> <td>2 scan skip.</td> </tr> <tr> <td style="text-align: center;">3</td> <td>3 scan skip.</td> </tr> <tr> <td style="text-align: center;">4</td> <td>4 scan skip.</td> </tr> <tr> <td style="text-align: center;">5</td> <td>5 scan skip.</td> </tr> </tbody> </table>	Setting	Description	0[default]	No scan skip.	1	1 scan skip.	2	2 scan skip.	3	3 scan skip.	4	4 scan skip.	5	5 scan skip.
Setting	Description														
0[default]	No scan skip.														
1	1 scan skip.														
2	2 scan skip.														
3	3 scan skip.														
4	4 scan skip.														
5	5 scan skip.														



Parameter	Description
Minimum detectable size *1	<p>The minimum detectable width can be set in the range of 0 to 1000mm. This function is effective for removing light interference, rain etc. To ensure stable detection at the configured size, the sensor also detects objects slightly smaller than the set value.</p> <p>Depending upon the spread of laser beam, the actual size and set value may differ from the set value. [Default:: 30mm]</p> <p>In the Region parameters of Area Designer Prime, the minimum detectable size can be configured for each region.</p>

Note

*1 Settings cannot be configured in LX mode.



3.14 Output

UCT has the following seven types of outputs.

3.14.1 Output 1 to Output 5

Output 1: When the object is detected in the output region 1, output 1 will switch to OFF state.

Output 2: When the object is detected in the output region 2, output 2 will switch to OFF state.

Output 3: When the object is detected in the output region 3, output 3 will switch to OFF state.

Output 4: When the object is detected in the output region 4, output 4 will switch to OFF state.

Output 5: When the object is detected in the output region 5, output 5 will switch to OFF state.

Below is an example of the detection outputs based on the position of detected objects:

Table 3-4 Detection Object Position and Output Status

Object position	Output 1	Output 2	Output 3	Output 4	Output 5
A	OFF	ON	ON	ON	ON
B	OFF	OFF	ON	ON	ON
C	OFF	OFF	OFF	ON	ON
D	ON	ON	ON	OFF	ON
E	OFF	OFF	ON	ON	OFF
F	ON	ON	OFF	ON	OFF

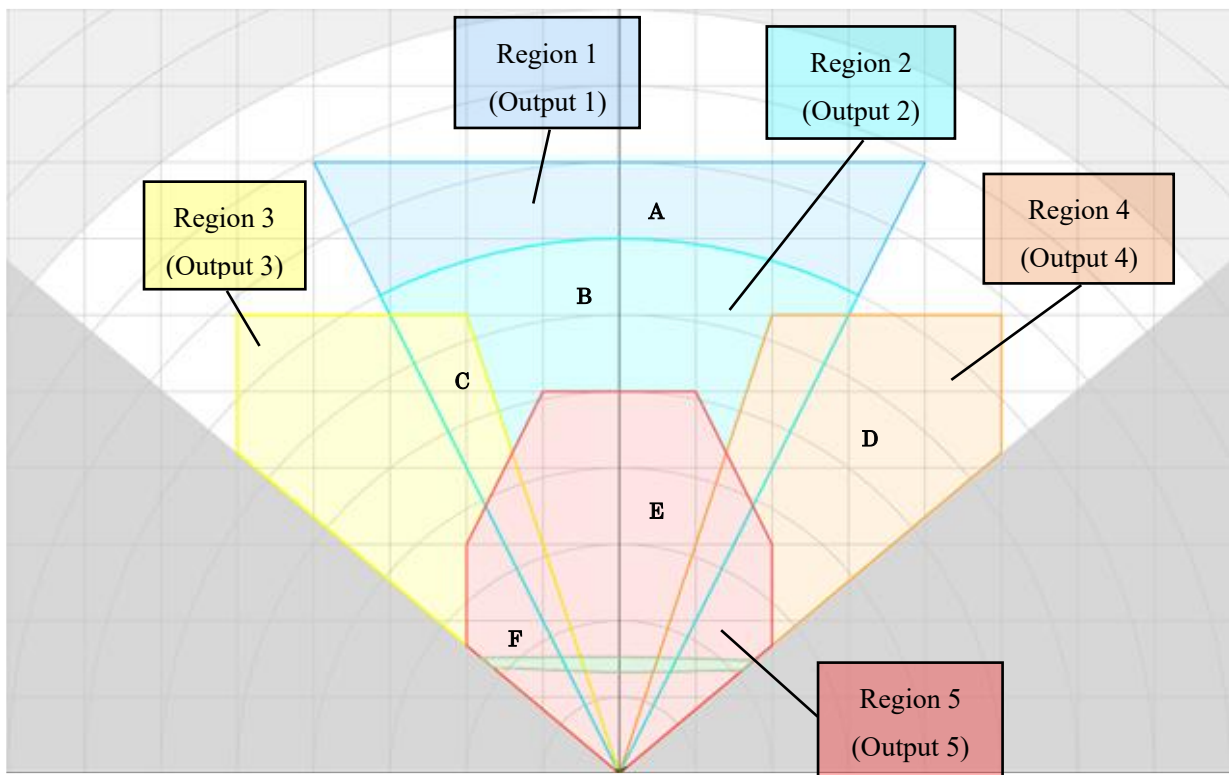

Figure 3-32 Region Detection Output

3.14.2 Malfunction Output

If the sensor enters a malfunction state due to the self-diagnosis function, the output will switch from ON to OFF. The output indicator lamps light according to the fault status as shown in the table below, and the power indicator lamp flashes. During a malfunction state, all detection outputs and reference outputs indicate the presence of an object.

Table 3-5 Main Malfunctions and Indicator Lamp Patterns

Pattern	Malfunction state	Message
	Motor malfunction	motor speed is not stable within defined timeout
		cannot read motor encoder
		motor is not spinning within defined timeout
	Laser malfunction	laser is not responding
	Malfunction simulation	sensor error condition by fault simulation

3.14.3 Reference Output

The reference function switches the reference output terminal to OFF when the measured distance deviates from the configured reference region.

3.15 Input

3.15.1 Area Input

Input1 allows you to select the detection area. It switches to Area 0 when ON and to Area 1 when OFF.

*OFF : High Level or Open, ON : Low level

3.15.2 Reference Input

By enabling the reference input in the dedicated application Area Designer Prime, Input 1 switches from area input to reference input. When the area input is disabled, the sensor always operates in Area 1. Turning the reference input on for more than one second and then turning it off again enables automatic generation of the reference area. For details, please refer to section 3.12.

*OFF : High Level or Open, ON : Low level



3.16 Indicator Lamp

The status of UCT is indicated by six indicator LEDs. These LEDs are located on the front of UCT, as shown in Figure 3-33. Table 3-6 shows the relationship between the LED indications and the output signals for each sensor status.

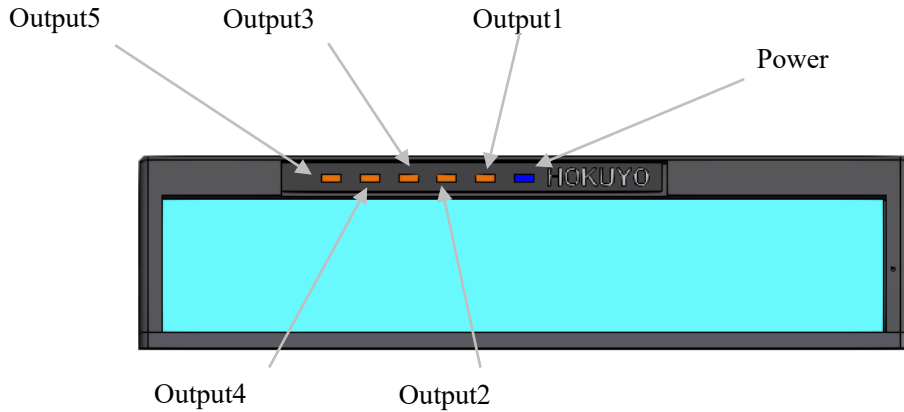

Fig 3-33 Indicator lamps

Table 3-6 Description of Indicator lamps

Indicator lamps	Description
Blue display: Power supply	ON during normal operation, blinks during start up, configuration, reference detection, and malfunction state.
Orange display: Output 1	ON during the object detection in the region of output 1.
Orange display: Output 2	ON during the object detection in the region of output 2.
Orange display: Output 3	ON during the object detection in the region of output 3.
Orange display: Output 4	ON during the object detection in the region of output 4.
Orange display: Output 5	ON during the object detection in the region of output 5.

- * In LX mode, the output indicator lamps are off except during malfunction state.
- * Immediately after power-on, the output state is indeterminate.
- * The detection output and the reference output can be logically inverted using the application software.

3.17 Laser Spot

Figure 3-34 shows the size of the laser spot emitted from UCT, which remains consistent across all layers and directions.

* The size value is for reference only.

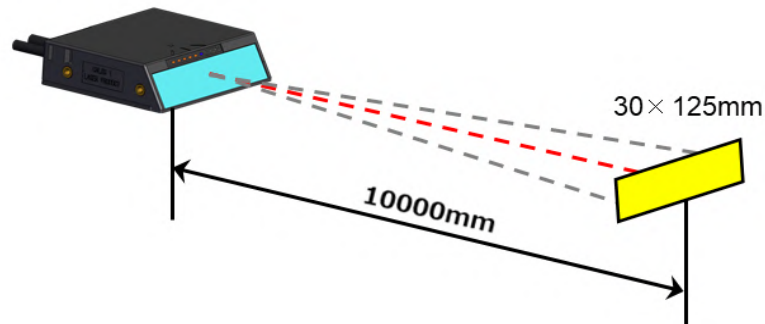

Fig 3-34 Size of Laser spot

- When attaching a cover or other accessory to UCT, make sure not to cover the area indicated by the red frame in Figure 3-35. Covering this area may cause false detection.



Caution

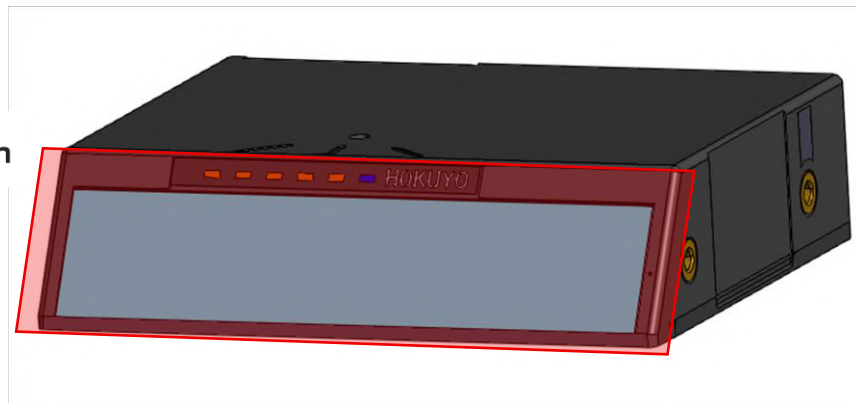

Fig 3-35 Cautions during installation

3.18 Close Range Sensitivity Filter

This filter is suitable for use in environments with dust or other airborne particles. With the close-range sensitivity set to “low”, unintended detections at close range can be suppressed. When dust or other very narrow objects are detected within the close-range area (approximately 50-1800mm), an error distance (65531) may be returned.

●Precautions When using the Close Range Sensitivity Filter

If a narrow object is located at very close range, the number of error steps may increase. Steps that return an error distance do not perform object-presence evaluation, which may lead to failure in detecting the intended target.

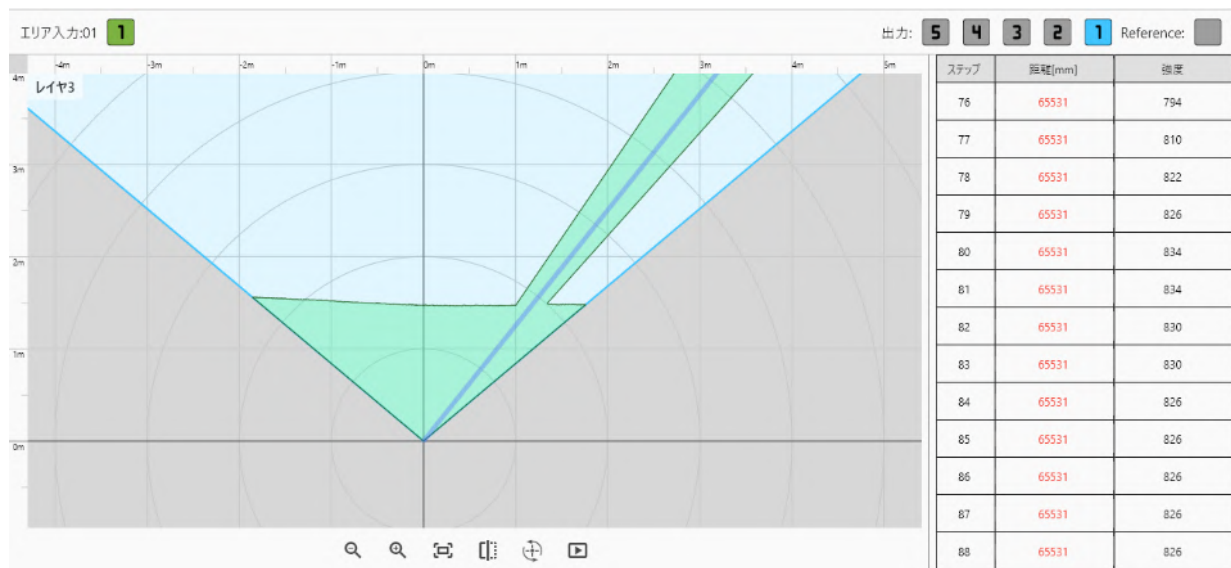

Figure 3-36 Blind Spots Caused by the Close-Range Sensitivity Filter

The sensor cannot detect objects with a width of 15mm or less; such targets will result in an error value. Consider the width of the target objects and whether to enable filtering accordingly.

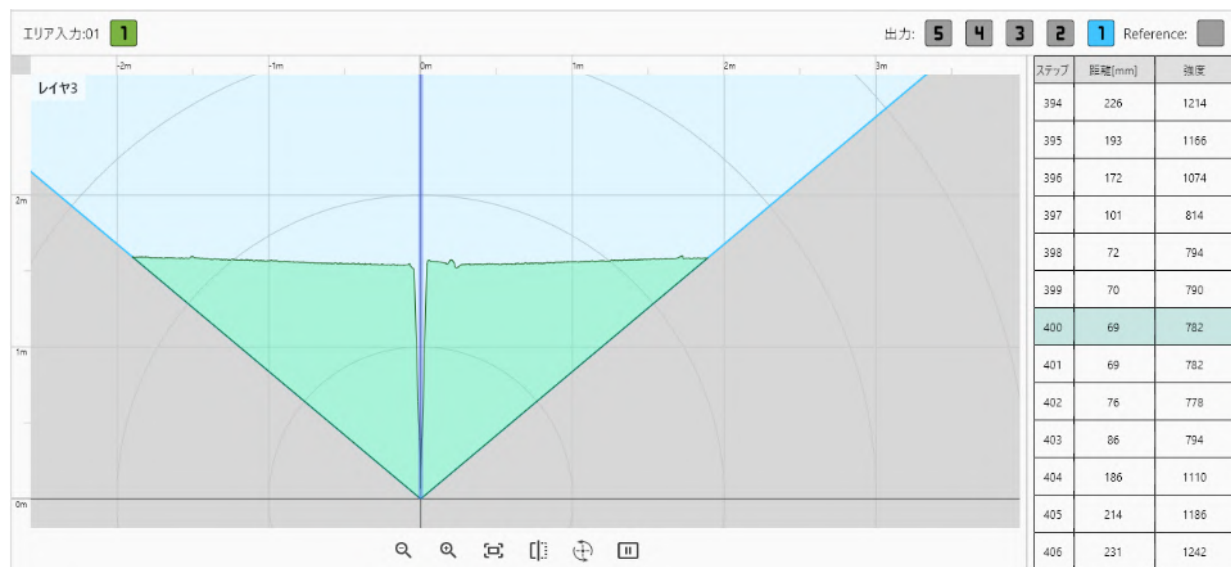

Figure 3-37 Detection of Objects 15 mm or Smaller – Close Range Sensitivity “Normal”

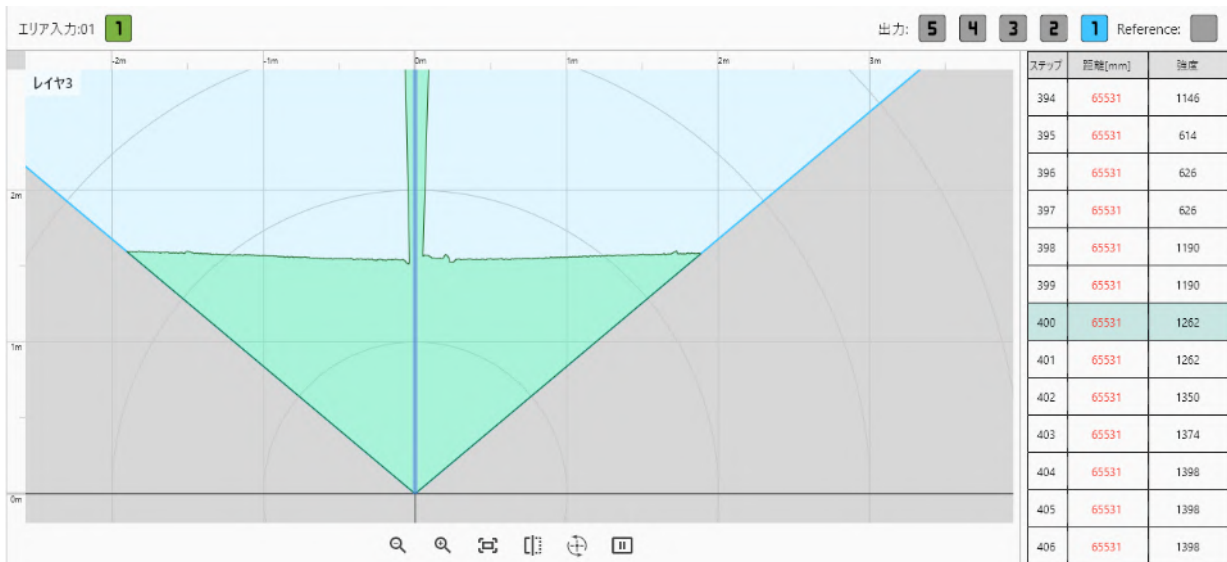

Figure 3-38 Detection of Objects 15 mm or Smaller – Close Range Sensitivity “Low”

With the close-range sensitivity set to “low”, detection near protruding shapes may become unstable. Please note that detection near wall or object corners, as well as around protruding shapes may result in error values.

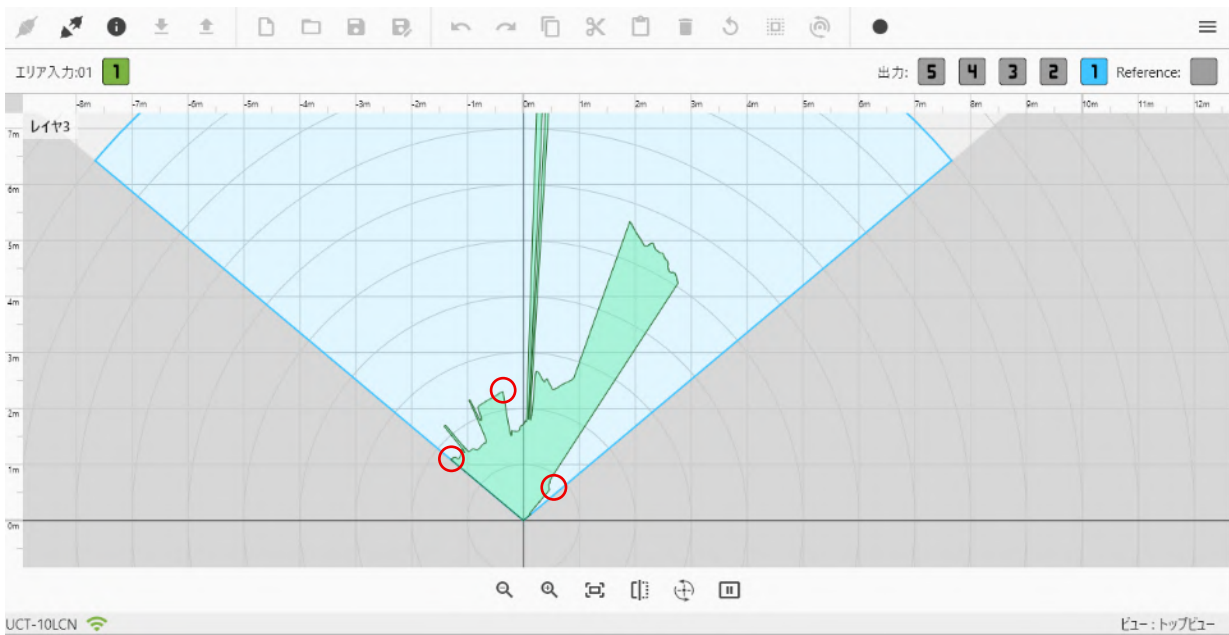

Fig 3-39 Unstable Detection Near Protruding Shapes – Close Range Sensitivity “Normal”

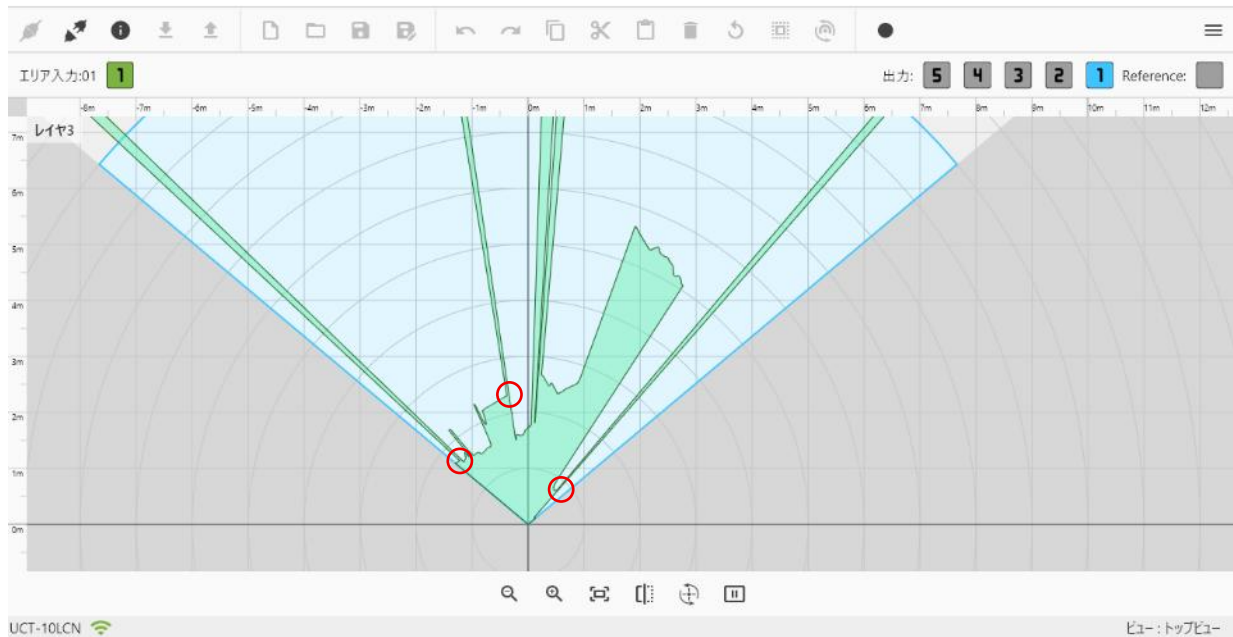

Fig 3-40 Unstable Detection Near Protruding Shapes – Close Range Sensitivity “Low”



Caution

- When an error distance occurs at very close range, the blind area becomes larger.
- The sensor cannot detect objects with a width of 15mm or less; such targets will result in an error value.
Consider the width of the target objects and whether to enable filtering accordingly.
- Detection near the protruding shapes may become unstable.



4. Installation

This chapter describes precautions for sensor installation.

UCT can be mounted using screws through the threaded holes on either the bottom or the side surface.

The bottom mounting holes are used as the FG (frame ground).

Be sure to ground them using M4 screws.

- Side mounting: Use four M3 screws (thread depth: 3.5 mm).

Tightening torque: 30 cN·m

- Bottom mounting: Use two M4 screws (thread depth: 5 mm).

Tightening torque: 60 cN·m

4.1 Light interference

UCT uses a pulsed laser for object detection. There is a risk of false detection under strong ambient light conditions, such as sunlight. Users should examine the surrounding environment before installing the sensor. If operations in an environment with ambient light cannot be avoided, please take measures such as tilting the unit as shown in Figure 4-1 or installing a hood, and perform prior verification.

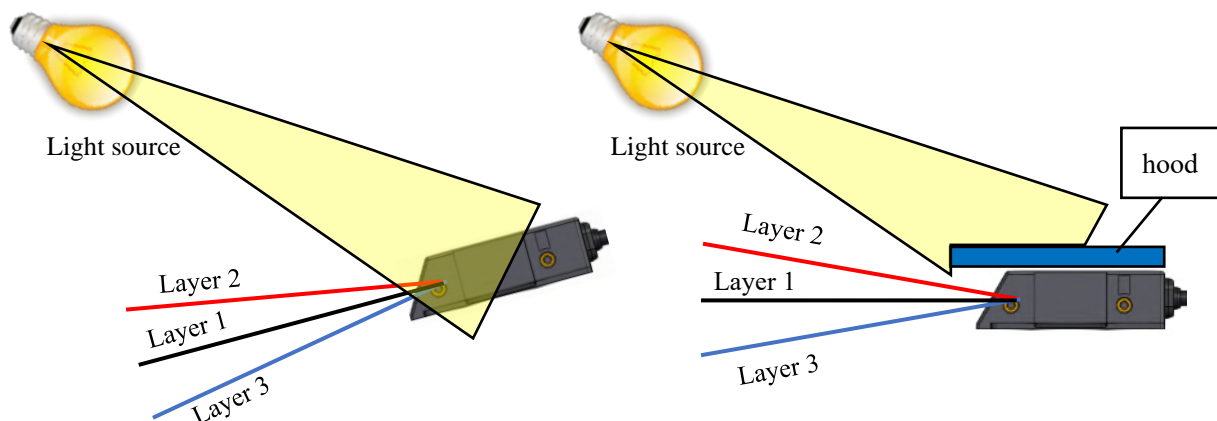

Fig 4-1 Installation under light interference



- Users must perform risk assessment for interference lights in the working environment before installation.

4.2 Mutual interference

When using multiple sensors of the same model, a sensor may incorrectly detect pulse laser signals from another sensor. Additional precautions are required. Configuring the interference-reduction filter helps reduce the likelihood of interference. However, this will reduce the response speed. For more details, refer to Section 3.13. Additionally, interference can be avoided by installing the sensors as shown below.

a) Adjustment of Installation Height

Stagger the installation height so that the optical axes of each layer do not enter the other sensor's optical window.

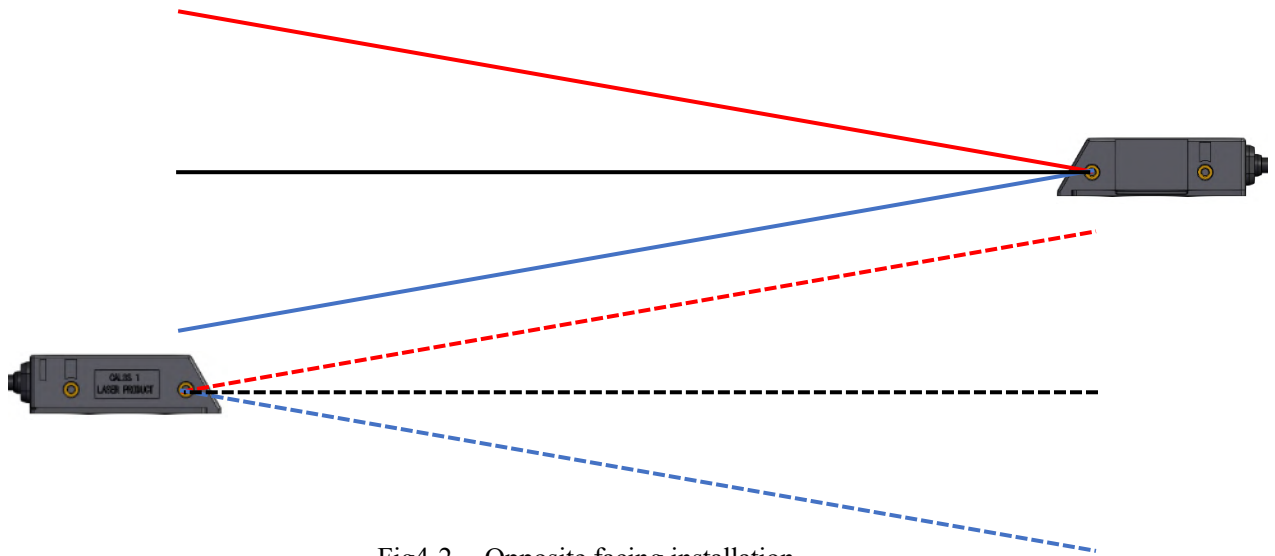

Fig4-2 Opposite facing installation

b) Adjustment of Installation Angle

Adjust the installation angle so that the optical axes of each layer do not enter the other sensor's optical window.

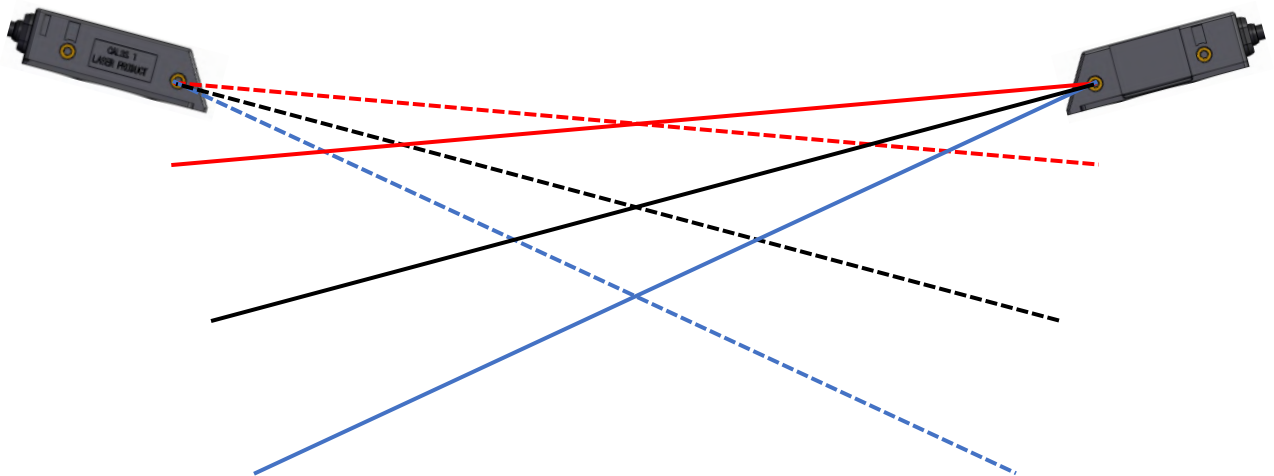

Fig 4-3 Opposite facing installation



C) Adding Shield in between UCT

By placing a shield between UCT units, the laser beam will not reach the opposite sensor, prevent possible mutual interference.

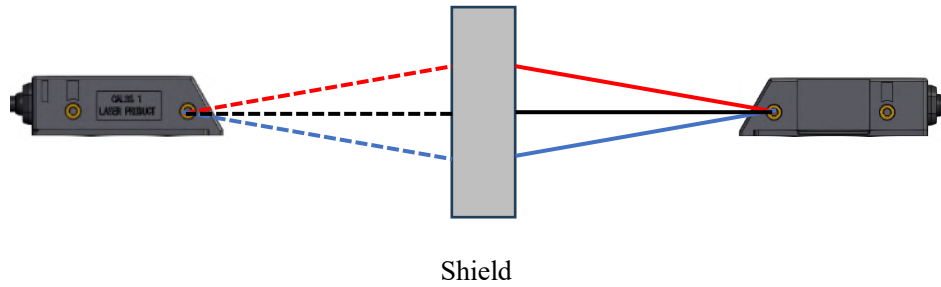

Fig 4-4 Opposite facing installation

Note • Material must be of solid opaque non-transparent material.

5. Wiring

This chapter describes precautions for wiring.

5.1 Precautions

During electric wiring, make sure that all devices are disconnected from power supply. Turn off all the power supply before wiring.

5.2 Power Supply

Make sure that power supply is either DC 12V or DC 24V (operation voltage range 10V to 30V)

If the rated output voltage exceeds this range, UCT could be damaged.

When a converter is used as power supply, make sure it fulfills the following requirements.

- A rated output voltage within range of DC 10V to 30V (more than 1A)
- The power supply must comply with the requirements of electromagnetic compatibility (EMC)

regulations of the respective country, states and district.



Danger

- For safety, switch off all the power supply during wiring.



Caution

- If there is an electric potential difference between UCT and ground of other connected devices, there is a possibility of malfunction due to noise or of damage. Prevent this by using potential equalization, isolation, etc.

5.3 Lead Wire Colors and Functions

5.3.1 Lead Wire Colors and Functions of UCT-10LCM

Table-5-1 shows the pin number and signal name of each connector.

Table 5-1 Wire color and function(UCT-10LCM)

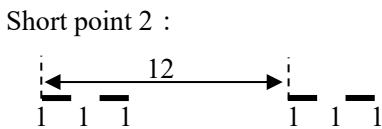
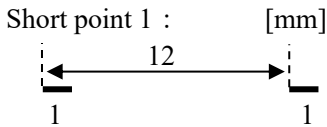
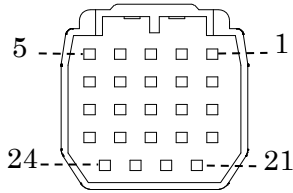

Number	Color	Signal	AWG
1	Orange (Red short point 1)	+VIN (DC12V/DC24V)	28
2	Orange (Black short point 1)	-VIN	
3	Gray (Red short point 1)	Output 1	
4	Gray (Black short point 1)	Output 2	
5	White (Red short point 1)	Output 3	
6	White (Black short point 1)	Output 4	
7	Yellow (Red short point 1)	Output 5	
8	Yellow (Black short point 1)	NC	
9	Pink (Red short point 1)	NC	
10	Pink (Black short point 1)	Input 1	
11	Orange (Red short point 2)	NC	
12	Orange (Black short point 2)	NC	
13	Gray (Red short point 2)	NC	
14	Gray (Black short point 2)	NC	
15	White (Red short point 2)	Reference Output	
16	White (Black short point 2)	Malfunction Output	
17	Yellow (Red short point 2)	NC	
18	Yellow (Black short point 2)	NC	
19	Pink (Red short point 2)	NC	
20	Pink (Black short point 2)	NC	
21	NC	NC	
22	NC	NC	
23	NC	NC	
24	NC	NC	

*The direction of inputs and outputs is indicated based on this product.

*Please leave unused input/output wires open.

*At the time of shipment, the connector listed below is already attached:

Manufacturer: Hirose Electric Co., Ltd Model: DF62B-24EP-2.2C

5.4 Input/Output Circuit

5.4.1 Input Circuit

Photo coupler input circuit

5.4.2 Output Circuit

NPN open collector circuit (maximum DC30V,100mA)

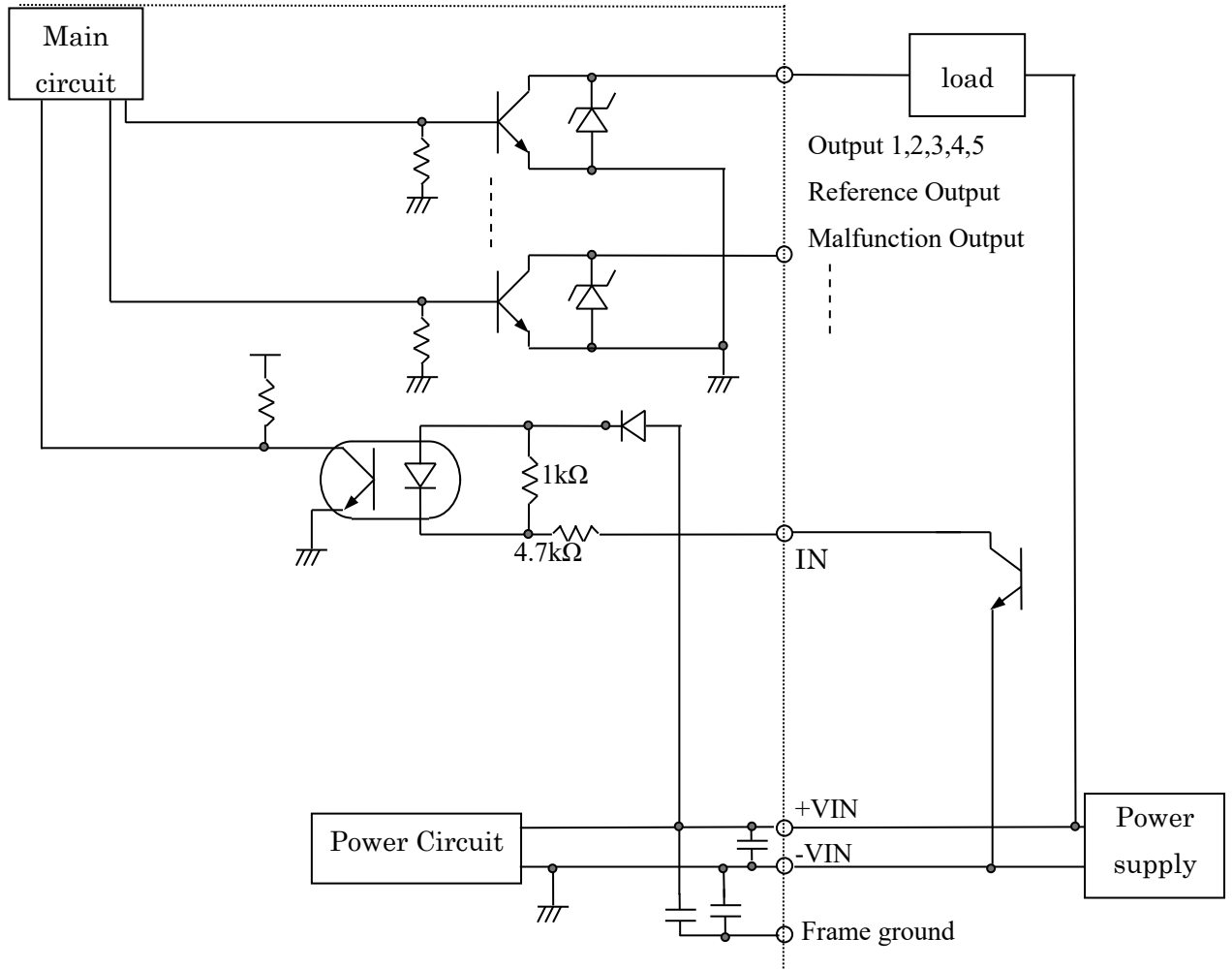

Fig5-1 Example of connecting input / output circuit

6. Setting of Area Designer Prime

Install the application software (Area Designer Prime) in a supported operating system and connect UCT using an Ethernet cable.

Area Designer Prime has the following functions:

- a) Configuration of detection area and reference area
- b) Configuration of various UCT functions
- c) Display of measurement data
- d) Record and playback of measurement data
- e) Project data management (Save and open of project data).
- f) I/O simulation

6.1 Area Designer Prime

Application software (Area Designer Prime) can be downloaded from our homepage.

For details of installation and operation please refer to Area Designer Prime Instruction manual. (C-41-02680)

6.2 System Requirement

Table 6-1 Minimum system required for Area Designer Prime

PC	RAM	8GB or more
	Hard disk	100MB minimum free space
Compatible OS	Microsoft [®] Windows 10, Microsoft [®] Windows 11	
Display	1024x768 dot or above	

*When acquiring measurement logs, approximately 3GB of available storage is required per hour.

The operation in the below system environment cannot be guaranteed.

- Other OS that is not mentioned above
- NEC PC98 series and its compatible device
- Self-assembled PC
- Multi boot environment
- Multi monitor environment

Note

- Operation is not guarantee even if the system requirements are fulfilled.
- When configuring UCT, please read this manual and the Area Designer Prime instruction manual carefully. You can also check from the options in Area Designer Prime.



7. Communication

7.1 Ethernet Setting

7.1.1 Initial Value

Initial value of IP: 192.168.0.10

Initial UDP Destination IP Address: 192.168.0.100

Port No.: 10940

7.1.2 Changing IP Address

It is possible to change and reset the IP address using a specialized application (IP Discovery). For details on installation and operation of IP Discovery, please refer to IP Discovery manual. (C-41-02603)

The UDP destination IP address can be changed using "Area Designer Prime".

7.2 IMU Setting

The Full-Scale settings and axis definitions of the IMU are as follows.

Accelerometer Full-Scale Range	$\pm 16g(2048\text{LSB}/g)$
Gyroscope Full-Scale Range	$\pm 2000\text{dps}(16.4\text{LSB}/\text{dps})$
Output Data Rate	1KHz

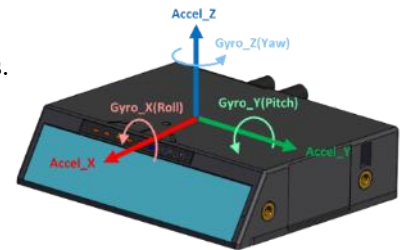

*Using VSSP, data is acquired every 20ms in batches of 20 segments of 1ms each.

*Functions for Magnet_X, Magnet_Y, and Magnet_Z are not supported.

7.3 Communication Protocol

For details on the communication protocol, refer to SCIP Communication specification (C-42-04609) and VSSP Communication specification(C-42-04610).

7.4 Detail on Measurement Values

Table 7-1 shows the meaning of the distance value x measured at each step in SCIP/VSSP communication.

Table 7-1 Distance values in SCIP/VSSP communication

Distance value (x)	Meaning
$x < 10$	Outputs 10 mm.
$10 \leq x \leq 30000$	Outputs the measured distance value in mm.
$30000 < x$	Outputs the value "65533." This value is also output when no object is detected or if the object cannot be measured.
$x = 65531$	Outputs this value when processed by the close range sensitivity filter.

*In the case of VSSP, error distance values such as "65531" or "65533" are not output.

8. Inspection and Maintenance

Inspection and maintenance are necessary for safety operations. Users must ensure that inspection and maintenance are carried out as specified.

Before performing inspection and maintenance, confirm the following items.

- a) The machine monitored by UCT is switched OFF
- b) The surroundings of the working environment are safe



Danger

- Do not modify or disassemble UCT during inspection as this will affect the detection capability of the sensor leading to critical injury or death.



Caution

- This manual only suggests the basic steps for inspection and maintenance. User should perform additional inspection and maintenance if needed.
- User should follow necessary steps in accordance with the working environment
- All inspections should be performed during initial commission of UCT.

8.1 Pre-operation Inspection

After configuration is completed, a pre-operation inspection test should be performed using a test piece. Users should perform this inspection without connecting the sensor to the system. Table 8-1 shows an example of pre-operation inspection items list.

Table 8-1 Pre-operation inspection list

No.	Check item	Condition		Remark
		Yes	No	
1	UCT is correctly mounted at the intended location and screws are firmly fastened			
2	All the wirings are correctly connected			
3	When the test piece is placed in the detection area Output 1 to 5 switch from ON state to OFF state			
4	When the test piece is removed from the detection area Output 1 to 5 switch from OFF state to ON state			
5	Area switching is according to input signal			

* Must check items 3 and 4 for all the areas and reference output.



8.2 Operation Inspection

This test should be performed when a pre-operation inspection is completed. This operation inspection must be performed only after sufficient safety measures have been taken. If this inspection test is done before pre-operation test, the system can get damaged. Table 8-2 is an example of operation inspection list.

Table 8-2 Operation inspection list

No.	Check item	Condition		Remark
		Yes	No	
1	When the test piece is placed in the detection area Output 1 to 5 switch from ON state to OFF state			
2	When the test piece is removed from the detection area Output 1 to 5 switch from OFF state to ON state			
3	Area switching is according to input signal			
4	Predetermined system operation is carried out as expected			

* Must check items 1 and 2 for all the areas and reference output.

8.3 Daily Inspection

Below Table 8-3 shows an example of the items that should be checked during daily inspection.

Table 8-3 Daily inspection list

No.	Check item	Condition		Remark
		Yes	No	
1	UCT is correctly mounted at the intended location and screws are firmly fastened			
2	All the wirings are correctly connected			
3	When the test piece is placed in the detection area Output 1 to 5 switch from ON state to OFF state			
4	When the test piece is removed from the detection area Output 1 to 5 switch from OFF state to ON state			
5	Area switching is according to input signal			
6	Predetermined system operation is carried out as expected			

* Must check items 3 and 4 for all the areas and reference output.



8.4 Periodical Inspection

Periodical inspection should be performed to ensure the detection capability of UCT. Table 8-4 below shows an example list of periodical inspection items. It is recommended to perform this inspection in six months interval. This inspection should be performed together with daily inspection.

Table 8-4 Periodical inspection list

No.	Check item	Condition		Remark
		Yes	No	
1	Screws are tightly fastened			
2	No displacement from the original mounting position			
3	No scratch or crack on the optical window			
4	Screws are tightly fastened			
5	No visible damage to UCT			
6	Cable connector is in good condition and tightly fastened			
7	When the test piece is placed in the detection area Output 1 to 5 switch from ON state to OFF state			
8	When the test piece is removed from the detection area Output 1 to 5 switch from OFF state to ON state			
9	Area switching is according to input signal			
10	Predetermined system operation is carried out as expected			

* Must check items 7 and 8 for all the areas and reference output.

Note

- For the traceability purposes it is recommended to maintain and store the maintenance and inspection records.

8.5 Cleaning the Optical Window

Dust covering the optical windows affects the detection capability of UCT. When you install UCT in a dusty environment, regular cleaning of the optical window is needed.

According to the contamination situation follow the below method:

- 1) Blow off the dust on optical window using air-blower.
- 2) Wipe the optical window with a clean, soft cloth.
- 3) Clean the optical window with mild detergent if it is contaminated with oil/grease particles.
Next, wipe off the mild detergent with water.
- 4) Finally, wipe the optical window in a vertical direction.

Example of soft cloth ... Bencot M-3 II (Asahi KASEI)



- Disconnect the system when cleaning the optical window.
- If above-mentioned contents are not followed it could lead to serious damage on the machine, critical injury and death.



- Do not use organic solvents (such as thinner, benzene and acetone) for cleaning. Plastics parts and paint might be affected.

9. Troubleshooting

While using this sensor, if problem occurs, then refer to the following table.

Table-9-1 Troubleshooting list

situation	Possible reason	Solution suggestion
UCT is not operating	Power supply is OFF /Over voltage/Under voltage	Make sure power supply is ON. Voltage is within the specification.
	Cable is damaged	Make sure cable is in good condition
Blue LED does not light	Normal voltage is not supplied.	Make sure voltage is within the specification.
UCT does not connect with Area Designer Prime	PC trouble	Check the PC's specification. Make sure the specification is compatible. Close other unrelated applications and reconnect.
	Power supply is OFF	Make sure the power supply is ON. Voltage is within the specification. Power supply cable is in good condition.
	Ethernet cable is not connected to LAN port	Make sure the Ethernet cable is connected to both PC and UCT.
	IP address of PC is not set	Set the IP address of the PC (Refer to below URL) https://www.hokuyo-aut.co.jp/products/data.php?id=4
Obstacles are not detected inside the selected detection area	Power supply is OFF	Voltage is within the specification.
	UCT is in malfunction state	Make sure that power supply LED is in normal state Restart UCT if it is blinking.
	Minimum detectable size configuration	Make sure that object width in detection area is more than minimum detectable size configuration.
Output remains OFF even if no object is in the detection area	Light interference	Install UCT in a location interference light, or set up UCT with an angle to avoid external light interference. Refer to chapter 4 "Light interference" for countermeasures.
	Mutual interference	Please install UCT at an angle to prevent overlap of their detection planes or try using the Interference Reduction Filter. Refer to chapter 4 "Mutual interference" for countermeasures.
	Contaminated optical window	Check for any contamination or damage on the optical window.
	Floor is detected	Make sure floor is not detected. Reconfigure the detection area.
	Background is detected	Make sure that the background is not within the detection area. Reconfigure the detection area.

	Malfunction state due to self-diagnostic function	Make sure power supply LED is not blinking (normal state).
	Hysteresis setting	Reconfirm the hysteresis setting.



- For repairing UCT, please contact our nearest distributor or sales representative. Do not repair or disassemble UCT. Such modifications will void the warranty.

10. Specification

Product name	Scanning Laser Range Finder
Model	UCT-10LCM
Supply voltage	DC12V/DC24V (operation range: 10 to 30V, ripple within 10%)
Power consumption	3W
Light source	Laser semiconductor (905nm)
Laser safety	Class1 (IEC60825-1:2014) Class1 Laser Product
Accuracy *1	± 40mm
Repeated accuracy *1	$\sigma < 20\text{mm}$
Detection range and object *1	<p>■ Scan angle range: -45° to $+45^{\circ}$ 0.05m to 10m (reflectivity 90% white-kent sheet 600mm × 2000mm) 0.05m to 4m (reflectivity 10% black paper 600mm × 2000mm)</p> <p>■ Scan angle range: -50° to -45° and $+45^{\circ}$ to $+50^{\circ}$ 0.05m to 8m (reflectivity 90% white-kent sheet 600mm × 2000mm) 0.05m to 3m (reflectivity 10% black paper 600mm × 2000mm)</p> <p>Maximum measurement distance:30m Minimum detectable size:35mm(at 4m)、90mm(at 10m)</p>
Scan angle	100°
Vertical angles	Layer1: 0° , Layer2: $+3^{\circ}$, Layer3: -3° *Vertical angle in the front step
Scan speed	Multi-layer mode: 16.7ms (motor speed: 2400rpm / 3 layers) Single-layer mode: 50ms
Measurement resolution	1mm
Angular resolution	0.125°
Startup time	Within 10 seconds (may exceed under specific startup conditions)
Outputs	<p>Total 7 outputs (NPN open collector output, DC 30V, 100mA MAX, residual voltage < 2V)</p> <p>Output 1: OFF in case of detection within region 1 Output 2: OFF in case of detection within region 2 Output 3: OFF in case of detection within region 3 Output 4: OFF in case of detection within region 4 Output 5: OFF in case of detection within region 5 Output 6: ON during normal operation, OFF during malfunction Output 7: Reference Output (ON during normal operation)</p> <p>Note: Outputs 1 to 5 and Output 7 are switched OFF during a malfunction state</p>



Inputs	Total 1 input (photo-coupler input) Input 1: For switching the detection area
Output response time	Multi-layer mode: 37ms *2 Single-layer mode: 70ms Note: Additional ON/OFF delay settings are possible (LA mode only).
Area switching time	Multi-layer mode: 24ms Single-layer mode: 57ms
Interface	Ethernet 100BASE-TX
LED display	Power Indicator (blue): Lights up during normal operation, blinks during startup, configuration, reference output operation, and malfunction states. Output Indicators 1 to 5 (orange): Light up when detection occurs in the area (off during LX mode). They light up with a pattern corresponding to the malfunction mode in the event of a malfunction.
Connection	Power and I/O: Connector(1m), Ethernet: RJ45(1m)
Ambient operating temperature	-10 to +50°C ,below 85%RH (without dew, frost)
Storage temperature	-30 to +70°C ,below 85%RH (without dew, frost)
Ambient light *3	Less than 100,000lx (indirect light)
Vibration resistance	10 to 55 Hz, double amplitude of 1.5 mm, 2 hours in each of X, Y, and Z directions 55 to 200 Hz, 98 m/s ² (10 G), 2-minute sweep, 1 hour in each of X, Y, and Z directions
Shock resistance	196m/s ² (20G) X,Y and Z direction each 10 times
Electromagnetic Compatibility (EMC)	EN55011:2016+A1:2017+A2:2021 EN IEC 61000-6-4:2019 EN IEC 61000-6-2:2019
Protective structure	IP65
Weight	100 g (excluding cable)
Material	Optical Window: Acrylic Bottom case: Aluminum Top cover: Polycarbonate
Dimensions (W × D × H)	80mm × 65mm × 20mm
IMU *4	3-axis acceleration and 3-axis angular (TDK InvenSense: IIM-42652) Relative position of the IMU with respect to the measurement origin: X: 17.1 mm, Y: 8.2 mm, Z: -8.3 mm
Communication Protocol *5	SCIP(TCP/UDP) VSSP(TCP)

- *1 Under the factory standard testing conditions using white-kent sheet
- *2 Slowest response time applies when continuous detection is possible in multi-layer mode. If continuous detection is not possible, the response time will be the same as in single-layer mode.
- *3 Detection is not guaranteed under direct sunlight or strong ambient light conditions. Please ensure there is no direct sunlight entering the sensor.
- *4 For details, refer to the data sheet.
- *5 For details, refer to the respective communication specifications (C-42-04609, C-42-04610).



11. Applicable Directives and Standards

Table 11-1 shows the conformant EU directives and EN standards.

Table-11-1 Directives and Standards

Directives/Standard	Details
Directives	EMC Directives RoHS Directives
Electromagnetic Compatibility (EMC)	EN55011:2016+A1:2017+A2:2021 EN IEC 61000-6-4:2019 EN IEC 61000-6-2:2019

● About the laser safety

UCT laser safety standard is class 1.

Average laser power 1mW or less

Wave length..... 905nm(Infrared laser)

Beam size approximately 30 mm × 125 mm (at 10 m distance, front direction)
(for details, refer to Section 3.17)

Standard..... IEC60825-1 (2014)

About Laser Safety Standard Class 1: under normal operation conditions (operations which can be foreseen rationally) it is guaranteed as safety class laser. Additional measures are not necessary to maintain laser safety.

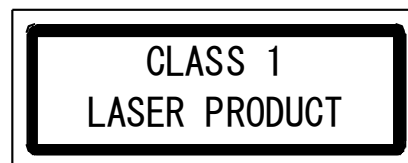
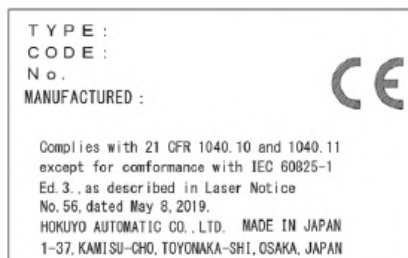
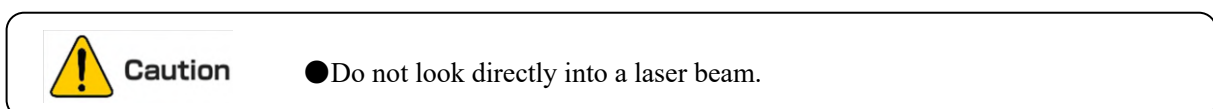

Fig 11-1 FDA Certified labels



12. Package Contents

The following items are included in the package:

- a) UCT-10LCM ×1



- b) User's Manual ×1

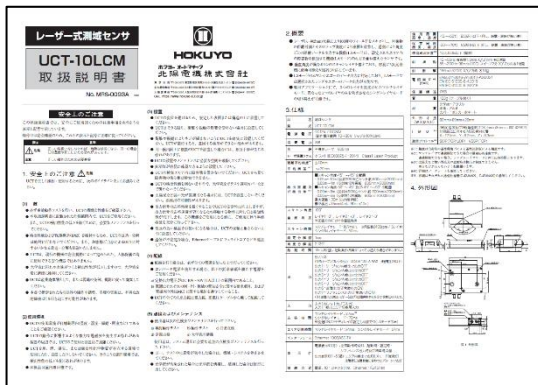

13. External Dimensions

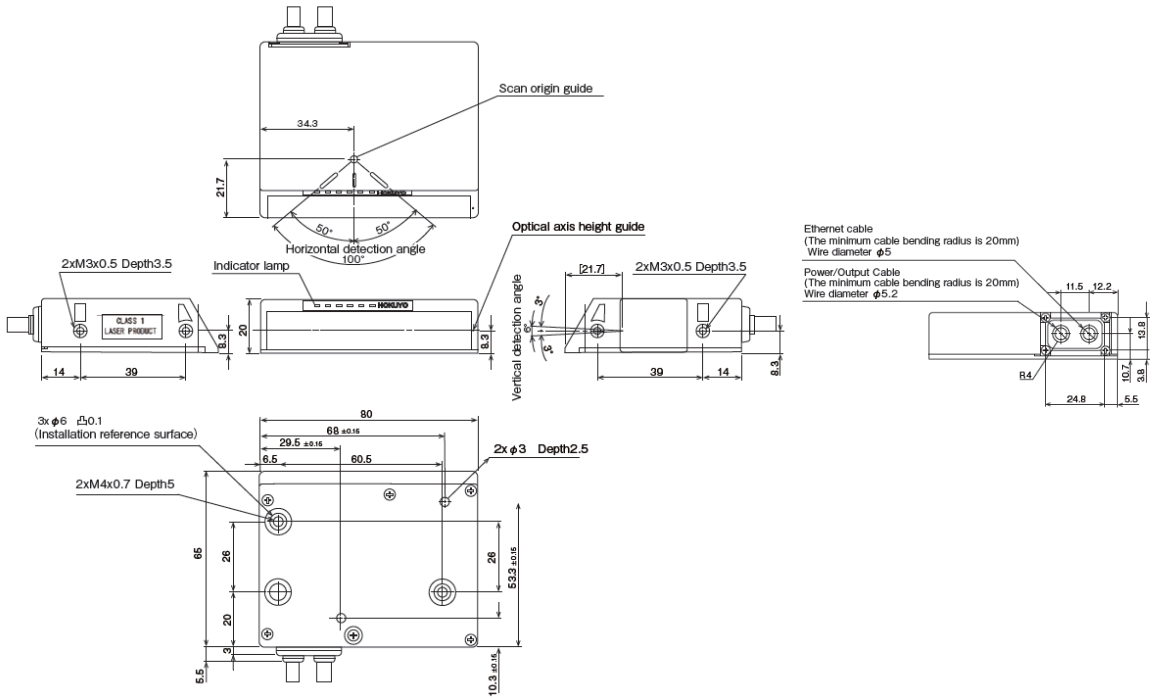

14. Revision History

Document No.	Amended No.	Revision date	Details
—	—	December 2025	First Release

★The contents described in this document are based on the information as of December 2025. The external dimensions; specifications etc. are subject to change without notice.

