



# Epec 6200 Control Unit

Technical Document

MAN000719

---



## Functional Versions

6200-223  
6200-224  
6200-268  
6200-269

## Document version history

Date	Notes
30.03.2020	First released version

Last build time 8:35 – 27 March 2020

## Table of Contents

<b>1</b>	<b>PREFACE</b> .....	<b>4</b>
1.1	<i>Use of Symbols</i> .....	4
1.2	<i>Basic Skills Required</i> .....	5
1.3	<i>Safety Guidelines</i> .....	5
1.4	<i>Warranty</i> .....	5
1.5	<i>Limited Liability</i> .....	6
1.6	<i>Environmental Statement</i> .....	6
<b>2</b>	<b>PRODUCT OVERVIEW</b> .....	<b>7</b>
<b>3</b>	<b>FUNCTIONAL VERSIONS</b> .....	<b>8</b>
<b>4</b>	<b>TECHNICAL DATA</b> .....	<b>10</b>
<b>5</b>	<b>CONNECTORS AND PIN ASSIGNMENTS</b> .....	<b>12</b>
<b>6</b>	<b>DO/DI</b> .....	<b>15</b>
6.1	<i>DO (digital output) mode</i> .....	15
6.2	<i>DI (digital input) mode</i> .....	15
6.3	<i>Functional block diagram</i> .....	17
<b>7</b>	<b>AI/DI</b> .....	<b>18</b>
7.1	<i>AI (Analog Input) mode</i> .....	18
7.2	<i>DI (Digital Input) mode</i> .....	18
7.3	<i>Functional block diagram</i> .....	20
<b>8</b>	<b>DI</b> .....	<b>21</b>
8.1	<i>Functional block diagram</i> .....	22
<b>9</b>	<b>ACCELEROMETER (OPTION)</b> .....	<b>23</b>
<b>10</b>	<b>+5 V REF</b> .....	<b>24</b>
10.1	<i>Protection features</i> .....	24
10.2	<i>Voltage monitoring</i> .....	24
10.3	<i>Functional block diagram</i> .....	25
<b>11</b>	<b>POWER SUPPLY</b> .....	<b>26</b>
11.1	<i>Overvoltage Protection</i> .....	26
11.2	<i>Power Consumption</i> .....	26
<b>12</b>	<b>INTERFACES</b> .....	<b>28</b>
12.1	<i>CAN Bus</i> .....	28
12.1.1	<i>CAN bus connection pins</i> .....	28
12.2	<i>RS-232</i> .....	30
12.3	<i>USB</i> .....	31
12.4	<i>Ethernet</i> .....	32
12.5	<i>Cellular GSM/UMTS/LTE</i> .....	33
12.6	<i>WLAN</i> .....	35
12.7	<i>GPS/GLONASS</i> .....	37
12.8	<i>LTE Diversity</i> .....	39
<b>13</b>	<b>INTERNAL DIAGNOSTICS</b> .....	<b>41</b>
13.1	<i>Temperature and Voltage Monitoring</i> .....	41
13.1.1	<i>Temperature Monitoring</i> .....	41
13.1.2	<i>Supply Voltage Monitoring</i> .....	41
13.2	<i>LED Indicator</i> .....	42
13.3	<i>+ 5 V REF Diagnostics</i> .....	44
13.3.1	<i>OVERLOAD</i> .....	44
13.3.2	<i>OVERVOLTAGE</i> .....	44

*Epec Oy reserves all rights for improvements without prior notice*

<b>14</b>	<b>APPROVALS AND SAFETY .....</b>	<b>45</b>
14.1	<i>EMC Tests.....</i>	45
14.2	<i>RF Tests .....</i>	46
14.3	<i>Environmental Tests .....</i>	55
14.4	<i>Simplified EU Declaration of Conformity .....</i>	56
14.4.1	<i>Frequency, mode and maximum transmitted power .....</i>	56
14.4.2	<i>Country Limitations .....</i>	56
<b>15</b>	<b>MECHANICS AND CABLING .....</b>	<b>57</b>
15.1	<i>Unit Dimensions .....</i>	57
15.2	<i>Mounting and Cleaning.....</i>	57
15.3	<i>Plugging and unplugging the cables/connectors .....</i>	59
15.4	<i>Cabling .....</i>	61
15.4.1	<i>System Topologies .....</i>	61
15.4.2	<i>CAN Bus Cabling .....</i>	63
15.4.3	<i>I/O Cabling.....</i>	66
15.4.4	<i>Ethernet Cabling.....</i>	68
15.4.5	<i>RS-232 Cabling.....</i>	70
15.4.6	<i>USB Cabling.....</i>	70
15.4.7	<i>Power Supply Cabling .....</i>	71
15.4.8	<i>Antenna Installation .....</i>	72
15.5	<i>Welding .....</i>	73
15.6	<i>Accessories and Ordering Codes .....</i>	74
15.6.1	<i>Related products .....</i>	74
15.6.2	<i>AMPSEAL Connectors .....</i>	76
15.6.3	<i>AMPSEAL cable dimensions .....</i>	76
<b>16</b>	<b>GLOSSARY .....</b>	<b>77</b>

*Epec Oy reserves all rights for improvements without prior notice*

# 1 PREFACE

---

## 1.1 Use of Symbols

This manual uses the following symbols to point out important information or safety instructions:



The information icon indicates important information and issues to be noted for the reader.



The caution icon indicates very important information or a warning. If the advices are ignored, it can result in personal injury or damage to software or equipment.



The (electrical) warning icon indicates a hazard which could cause an electrical danger and/or a personal injury.

The following symbols may be used on Epec's product labels:



Caution, surface may be hot.



CE compatibility

This symbol indicates that the product complies with the requirements set in the CE Standard.



WEEE symbol

This symbol indicates that the product must be sent to separate collection facilities for recovery and recycling when the end-user wishes to discard the product.



E17 Approval

This symbol indicates that the product is certified with normal automotive (E17) EMC (electromagnetic compatibility) standards.



FCC Logo

FCC Logo Devices authorized under the SDoC procedure have the option to use the FCC logo to indicate compliance with the FCC rules, 12 and the logo may be included in the instruction materials or as part of an e-label.



RCM (Regulatory Compliance Mark)

This symbol indicates that the product complies with the ACMA (Australian Communications and Media Authority) regulatory arrangements concerning electromagnetic compatibility and radio equipment.

*Epec Oy reserves all rights for improvements without prior notice*

## 1.2 Basic Skills Required

The user of this document must have basic knowledge of machine controlling, CAN communication, PLCopen programming according to IEC61131-3 and should have skills to use CODESYS 3.5 programming environment.

Refer to CODESYS manual for further information concerning the programming environment and required installations.

Refer to CAN and CANopen documentation from CAN in Automation (CiA) for further information on communication issues.

## 1.3 Safety Guidelines

The user of this documentation should follow general machine safety guidelines, directives and regulation appropriate to their country or market area.

A separate safety analysis is always recommended for the machine and its control system. The features of this product should be well documented in machine and control system documents so that the machine operator has the right information how to operate the machine correctly and safely.

The manufacturer does not assume any responsibility for this product being fit for any particular application, unless otherwise expressly stated in writing by the manufacturer.

This product complies with those certifications and standards that are mentioned in this manual. The manufacturer does not guarantee that this product complies with any other certification, standard or test other than mentioned in this manual.

This product is not field serviceable, so it should not be opened in any situation.

External fuses should be installed for the product or the system power supply.

The system should be designed and constructed according to the Epec general mounting and cabling instruction document.

Epec Oy reserves a right to improve its products without a further notice.

## 1.4 Warranty

Information concerning the warranty of this product can be found from *Epec General Sales and Warranty Terms*.

For more information, contact [sales@epec.fi](mailto:sales@epec.fi)

*Epec Oy reserves all rights for improvements without prior notice*

## 1.5 Limited Liability

The manufacturer shall under no circumstances be liable for loss of production, loss of profit, loss of use or any other consequential damages and/or indirect losses, whatever their cause may be. In case claims based on product liability are brought against the Manufacturer for which claims the manufacturer may be liable, the manufacturer's liability is limited to the extent normally covered under normal product liability insurances.

The buyer shall compensate the manufacturer to the extent that the manufacturer might be liable to pay damages as a result of claims based on product liability according to paragraph above.

## 1.6 Environmental Statement

The manufacturer has a certified ISO 14001: 2015 environmental management system and certified processes to manufacture products. The manufacturer acts in an environmentally responsible manner and always complies with valid environmental legislation and directives .

The manufacturer is committed to comply with all relevant product regulations and directives concerning product safety, and responsible sourcing of raw materials and components. The position paper on [REACH and RoHS compliance and Conflict Minerals](#) can be found from Epec Oy's website.

The manufacturer undertakes to arrange for the recycling and scrapping of products that are returned to the manufacturer by the buyer and/or products that are received by the manufacturer in connection with maintenance services and deemed unusable by the manufacturer.

This product complies with the European Community Directive 2012/19/EU on waste electrical and electronic equipment (WEEE) encouraging and setting specific criteria for the collection, handling and recycling of electric and electronic waste. Outside of the European Union, local guidelines for recycling shall be followed.



This product includes a lithium battery soldered on the PCB's bottom side (placed on the upper right part of the PCB). When recycling the product, make sure that the battery is removed from the PCB and recycled separately.

*Epec Oy reserves all rights for improvements without prior notice*

## 2 PRODUCT OVERVIEW

---

Epec 6200 Remote Access Unit (RAU) is a high-performance, programmable, control and communication unit for mobile machines. Epec 6200 RAU has multiple use cases such as data collection, communication gateway, remote access or edge computing. Epec 6200 RAU is fully compatible with the existing Epec control units and supports Epec GlobE remote management platform, Epec GatE secure access solution, CODESYS 3.5 WebVisu functionality, Epec MultiTool, Epec CANmoon and Epec PLCopen libraries.

Epec 6200 Remote Access Unit has some unique features listed below:

### Processing power and connectivity

- Powerful Dual/Quad Core Cortex-A9 ARM processor
- Internal Graphics Processing Unit (GPU)
- High internal memory capacity
- Linux embedded
- Supports wired interfaces: CAN, Ethernet USB and Serial port
- Wireless interface options: GSM, UMTS, LTE, GNSS, WLAN
- Supports Epec GlobE and GatE for remote access

### Mechanics & connectors

- Full aluminum housing, robust and heavy duty
- Light weight, small form factor
- Three point anchorage confirms firm mounting also on irregular surfaces
- Industrial connectors
- SIM card slot
- Programmable status LEDs

### Application programming

- CODESYS 3.5
- Epec MultiTool and CANmoon
- Supports PLCopen and CANopen®, easily scalable to meet the requirements of both small and large machines
- Open I/O and communication interface, possible to connect sensors, actuators, joysticks and other devices from other manufacturers to optimize the whole machine environment.
- For more information about programming, see *Epec Programming and Libraries Manual*, MAN000538 (provided in Epec Extranet)

*Epec Oy reserves all rights for improvements without prior notice*

### 3 FUNCTIONAL VERSIONS

This section describes the different product variants, also known as functional versions. The functional version and hardware revision can be found on your product's label.

Functional Version (HW revision)	6200-223 (6200C02)	6200-224 (6200C04)	6200-268 (6200C01)	6200-269 (6200C03)
Technical Manual ID	MAN000719			
Antenna for GSM/UMTS/LTE	x	x	x	x
Antenna for WLAN	x	x	x	x
Antenna for GPS/GLONASS	x	x	x	x
Antenna for LTE Diversity	x	x	x	x
CAN	2	2	6	6
RS-232	1	1	1	1
USB	1	1	1	1
Ethernet	2	2	2	2
SIM slot	x	x	x	x
5 V REF	1	1	1	1
Accelerometer	-	x	-	x
DO/DI	2	2	2	2
AI/DI	1	1	1	1
DI	2	2	2	2
Connectors	1xAMP23 1xmini-B USB (M12) 1xM12 4xSMA	1xAMP23 1xmini-B USB (M12) 1xM12 4xSMA	1xAMP23 1xmini-B USB (M12) 3xM12 4xSMA	1xAMP23 1xmini-B USB (M12) 3xM12 4xSMA

*Epec Oy reserves all rights for improvements without prior notice*

<b>Flash</b>	4 GByte	32 GByte
<b>RAM</b>	1024 MByte	
<b>NVRAM</b>	512 kByte	
<b>NVRAM Type</b>	MRAM	
<b>Processor</b>	32 bit CPU 792 MHz, Includes GPU	32 bit QuadCore CPU 792 MHz, Includes GPU
<b>IP Class</b>	IP67	
<b>OVP</b>	70 VDC	
<b>Temperature range</b>	-30... +60 °C -22...+140 °F	
<b>CODESYS version</b>	3.5	
<b>Supported CAN higher layer protocols</b>	CANopen SAE J1939	

*Epec Oy reserves all rights for improvements without prior notice*

## 4 TECHNICAL DATA

### General

<b>Processor</b>	32 bit Dual/Quad Core CPU 792 MHz  Processor is hardware specific
<b>Memory</b>	Flash memory: 4 GByte – 32 GByte RAM memory (DDR3): 1024 MByte Non-volatile memory: 512 kByte  Memory sizes are hardware specific, <i>6000SystemParameters.library</i> can be used for checking the memory sizes (for more information, refer to <i>Epec Programming and Libraries manual</i> ).
<b>Operating system</b>	Linux
<b>Programming</b>	CODESYS 3.5
<b>Power</b>	Nominal supply voltage 12/24 VDC systems (8,4 ... 36 VDC) Power consumption 85 W (+24 VDC, full load), 3,6 W (+24 VDC, idle)
<b>REF voltage outputs</b>	+5 V
<b>Diagnostics</b>	Supply voltage Unit temperature Software cycle time REF voltage monitoring 3 x Signal LED (green/red/blue)

### Mechanics

<b>Size / Outer dimensions</b>	182 mm x 153 mm x 55 mm 7.16 in x 6.02 in x 2.16in
<b>Weight</b>	1,2 kg 2.6 lbs
<b>Protection class</b>	IP 67
<b>Case material</b>	Aluminum
<b>Operating temperature</b>	-30... +60 °C

*Epec Oy reserves all rights for improvements without prior notice*

	-22...+140 °F
<b>Storage temperature</b>	-40... +80 °C -40...+176 °F

### Connectors and communication

<b>Connectors</b>	1 x AMP23 1 x mini-B USB (M12) 1 x M12 1-4 x SMA antenna connector (Hardware specific)		
<b>Communications / Interfaces</b>	<b>Interface</b>	<b>Amount</b>	<b>Connector</b>
	CAN 2.0 B	2-6 (Hardware Specific)	AMP23
	RS-232	1	AMP23
	USB	1	M12 miniB-USB: high speed (480 Mbps)
	Ethernet	2	M12 (8 pin)
	GSM/UMTS/ LTE/ WLAN/ GPS/GLONASS	1-4 (Hardware Specific)	SMA antenna SIM card slot
<b>Other features</b>	RTC (Real-time Clock) with battery Accelerometer (option)		
<b>I/O pins total</b>	5		
<b>Outputs</b>	2x	DO/DI (sourcing, up to 1 A)	
<b>Inputs</b>	2x	DI (pull-down to GND)	
	1x	AI/DI (0-5 V / 0-22 mA and pull-up selection by application)	

*Epec Oy reserves all rights for improvements without prior notice*

## 5 CONNECTORS AND PIN ASSIGNMENTS



This manual describes the full hardware version. Some of the features are optional and not implemented in all hardware versions.

The connectors are placed in the unit according to the following figures:

Connector	Option	Connector type
X7	GSM/UMTS/LTE	RP-SMA FEM
X8	WLAN	SMA FEM
X9	GPS/GLONASS	SMA FEM
X10	LTE Diversity	RP-SMA FEM

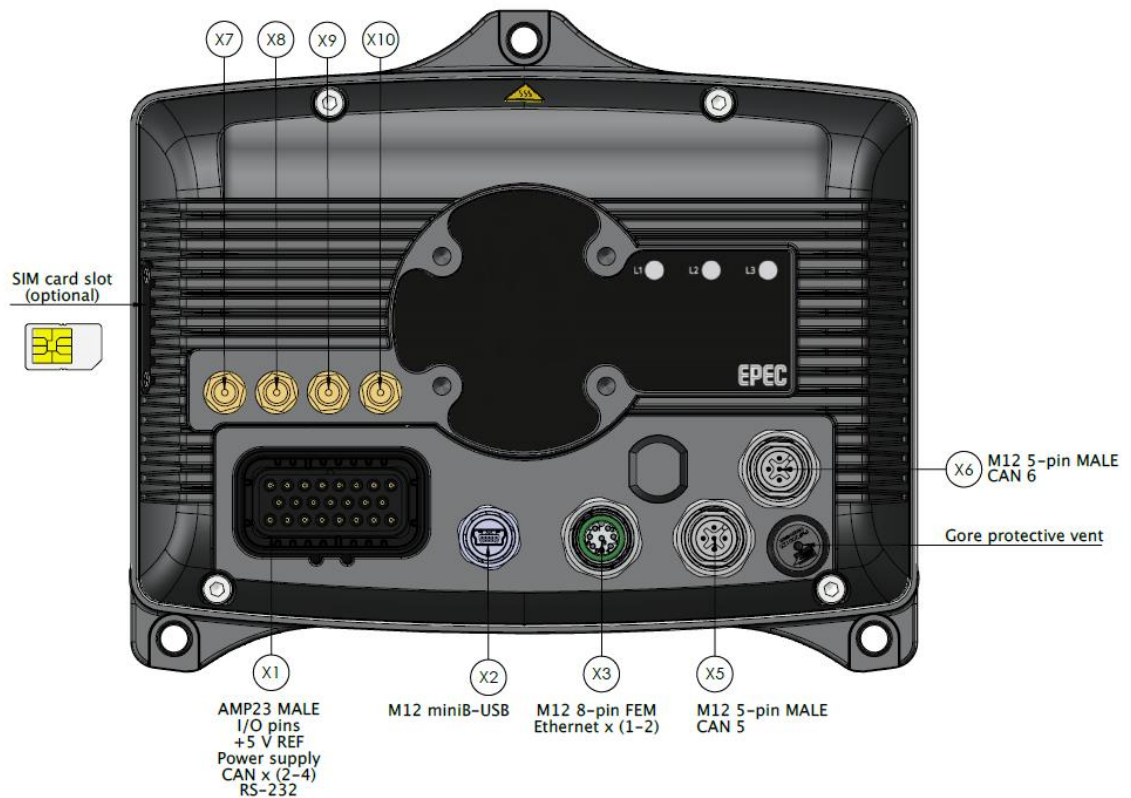

*Epec Oy reserves all rights for improvements without prior notice*

**X1, AMP23 male connector (USB, RS-232, CAN1, CAN2, DI, AI/DI, DO/DI, + 5V REF, power supply)**

Picture	Pin	Signal	I/O Type
	1	CAN3_L*	
	2	CAN3_H*	
	3	RS-232_TXD	
	4	RS-232_RXD	
	5	CAN4_L*	
	6	CAN4_H*	
	7	CAN1_L	
	8	CAN1_H	
	9	DATA_GND	
	10	DATA_GND	
	11	DIGITAL_INPUT_1	<a href="#">DI</a>
	12	DIGITAL_INPUT_2	<a href="#">DI</a>
	13	CAN2_L	
	14	CAN2_H	
	15	CAN_SHIELD	
	16	+5 V REF	
	17	ANALOG_INPUT	<a href="#">AI/DI</a>
	18	AI GND	
	19	I/O_GND	
	20	DIGITAL_OUTPUT_1	<a href="#">DO/DI</a>
	21	DIGITAL_OUTPUT_2	<a href="#">DO/DI</a>
	22	PWR_GND	
	23	PWR_IN	

*\*Hardware specific*

**X2, mini-B-USB connector**

Picture	Pin	Signal
	1	+5 V (max 500 mA)
	2	D-
	3	D+
	4	ID
	5	GND

*Epec Oy reserves all rights for improvements without prior notice*

### X3, M12 connector (8 pin FEM, ethernet)

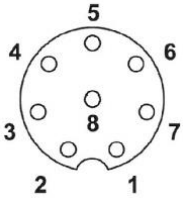
Picture	Pin	Signal
	1	RD2+
	2	TD2+
	3	TD2-
	4	RD1-
	5	TD1+
	6	RD1+
	7	RD2-
	8	TD1-

### X5, M12 connector (5 pin MALE)

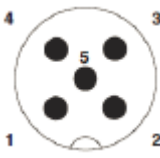
Picture	Pin	Signal
	1	CAN shield
	2	NC
	3	GND
	4	CAN5 H
	5	CAN5 L

### X6, M12 connector (5 pin MALE)

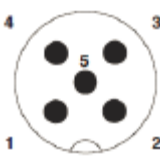
Picture	Pin	Signal
	1	CAN shield
	2	NC
	3	GND
	4	CAN6 H
	5	CAN6 L

*Epec Oy reserves all rights for improvements without prior notice*

## 6 DO/DI

---

Possible pin modes:

- Sourcing DO mode (pull-up)
- Sourcing DO mode (pull-down)
- DI mode (pull-up)
- DI mode (pull-down)

### 6.1 DO (digital output) mode

- This pin type is a current sourcing output with a pull-up selection
- The pin connects the load to a positive supply voltage
- This pull-up feature is for open load detection when the pin is used as an output
- These outputs have a switching element called a smart FET. It has integrated features to protect itself and also the external pin, wiring and actuator.
- When used as an output, the input feature indicates the output FET's state



It is recommended to use the function blocks in *DigitalOutputDiagnostics* library to protect and diagnose outputs when used as digital outputs. For more information, refer to *Epec Programming and Libraries Manual*.

### 6.2 DI (digital input) mode

- This pin can be used as a digital input (DI) by using the output state monitoring feature
- In this case, the output (DO) functionality of the pin type must be kept OFF
- This pin can be used also with NPN-type sensors – sensors with open collector/open drain
- It's highly recommended to use closed loop connections when the output pin is used as an input. By keeping this simple principle in your mind you will avoid many unknown problems later on

*Epec Oy reserves all rights for improvements without prior notice*

**Electrical characteristics**

Symbol	Parameter	Conditions	Min	Max	Units
$V_{Level}$	Output voltage	Output Off, Pull-up selected, Unconnected pin, $U_{in} = 24\text{ V}$ $V_{Level} = U_{in}/1,3$	typ. 18,5		V
$I_o$	Nominal Output Current	Output On (Note 3, 4)	0	1	A
$I_{o-lim}$	Internal current limitation	Output On (Note 2, 6)	typ. 12		A
Digital status input					
$R_i$	Input Resistance	Output Off, Pull-up resistor not selected, $V_i < U_{in}$ (referenced to GND)	typ. 44		k $\Omega$
		Output Off, Pull-up resistor selected, (referenced to $U_{in} / 1,3$ )	typ. 8,1		k $\Omega$
$V_{IH}$	High Voltage level	Output Off (Note 3, 8)	4,2	$U_{in}$	V
$V_{IL}$	Low Voltage level	Output Off (Note 8)		3,2	V
$V_{I-range}$	Input voltage range	(Note 7)	-0,5	$U_{in}$	V
$t_i$	Digital Status Input Pulse Width	(Note 1, 5)	> tC		ms
$C_i$	Input pin capacitance		typ. 1		nF

**Note 1:** tC denotes software cycle time.

**Note 2:** Current limit for short circuit protection to protect cabling and to limit internal power dissipation.

**Note 3:** Exceeding the max value might cause damage to input.

**Note 4:** The maximum output current depends on the load and temperature.

**Note 5:** Pulse width must be greater than the software cycle time. For example with 50/50 pulse ratio, the pulse frequency is  $1 / (2 \cdot \text{pulse width})$

**Note 6:** When the limit is exceeded, the output voltage circuit starts to limit the current by switching the output voltage. The switching does not affect the application software.

**Note 7:** Overload conditions

**Note 8:** Includes hysteresis. The input state is maintained until the second voltage limit is exceeded.

*Epec Oy reserves all rights for improvements without prior notice*

**6.3 Functional block diagram**

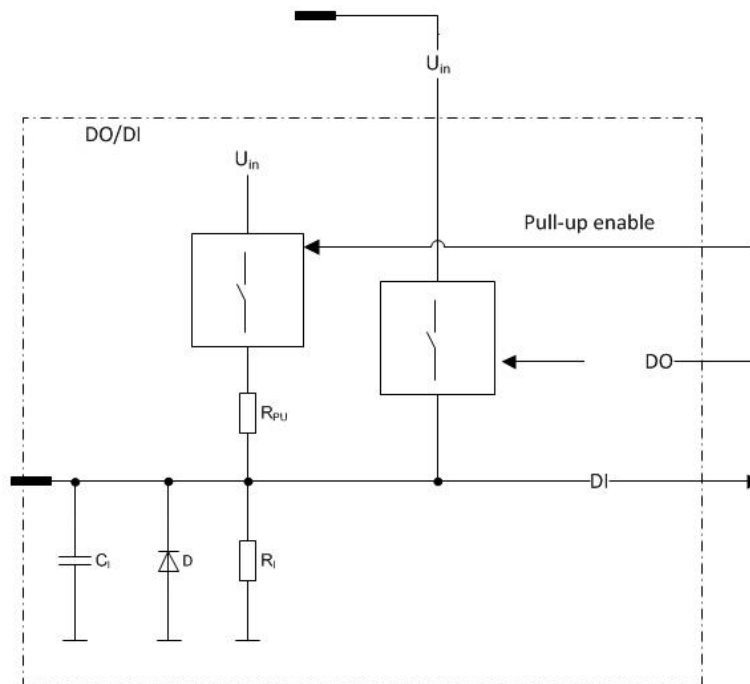

*Epec Oy reserves all rights for improvements without prior notice*

## 7 AI/DI

---

Possible pin modes:

- +5 V AI voltage mode (pull-down)
- +5 V AI voltage mode (pull-up)
- +20 mA AI current mode
- DI mode



This pin has a dedicated AI GND pin (X1.18) that is internally connected to the I/O ground and data ground pins.

### 7.1 AI (Analog Input) mode

- The configurable features are controlled by two control signals:
  - One control signal is for selecting:
    - Voltage mode: High impedance input for signal from 0 to 5 V with or without pull-up
    - Current mode: Low impedance input for signal from 0 to 22 mA
  - One control signal is for selecting (when in voltage mode):
    - Pull-up mode to +5 V by a resistor
    - Pull-down mode to GND by a resistor

### 7.2 DI (Digital Input) mode

- This pin can also be used as a digital input by using an application library
- The pin must be configured to voltage mode when used as a digital input



Configure the pin to current mode before applying the current signal.



A switch will disconnect the measurement circuit if an overvoltage event is detected.

Overvoltage protection mode is indicated with a dedicated signal (*DEV\_DSC\_OVP\_STATE\_X1\_17*). The protection mode is active as long as the overvoltage persists.

The protection circuit can be bypassed (the switch will reconnect the measurement circuit) momentarily with a reset signal (*DEV\_DSC\_OVP\_RESET\_X1\_17*). The signal is edge activated and the bypass time is fixed.

*Epec Oy reserves all rights for improvements without prior notice*

**Electrical characteristics**

Symbol	Parameter	Conditions	Min	Max	Units
$V_i$	Input Voltage measuring range	Voltage mode	0	5,5	V
	Overvoltage Detection Threshold	Protection mode not active (Note 5)	typ. 7,2		V
		Protection mode active (Note 5)	typ. 5,6		V
	Scaling factor	Voltage mode (Note 4)	10/11		
		Current mode (Note 4)	10/11		
$V_{PU}$	Pull-up voltage	(Note 1)	typ. 5		V
$I_i$	Input Current measuring range	Current mode	0	22	mA
$R_i$	Input Resistance	Voltage mode, pull-up resistor not selected (referenced to GND)	typ. 70		k $\Omega$
		Voltage mode, pull-up resistor selected (referenced to + 5 V)	typ. 2200		$\Omega$
		Current mode (referenced to GND)	typ. 220		$\Omega$
		Overvoltage protection mode, $V_i >$ Overvoltage detection threshold (referenced to GND)	typ. 9,6		k $\Omega$
BW	Input Low Pass Filter Bandwidth	Voltage mode (Note 3)	typ. 1		kHz
		Current mode (Note 3)	typ. 1		kHz
$I_E$	Input Error	Voltage mode		0,25	V
		Current mode		1,1	mA
$C_i$	Input pin capacitance		typ. 4,4		nF
$V_{I-range}$	Input Voltage Range	Voltage mode (Note 2)	-0,5	43	V
		Current mode (Note 2)	-0,5	43	V

**Note 1:** Temperature-dependent.

**Note 2:** Exceeding the max value might cause damage to input.

**Note 3:** 2nd order low pass filter

**Note 4:** HW multiplies the measurement by 10/11. The effect is compensated in *6107Int.library* (the measurement is multiplied by 11/10), so the measurement is automatically accurate when using Epec programming libraries. For more information about conversions, refer to *Epec Programming and Libraries* manual.

**Note 5:** When protection mode is active the measurement circuit is disconnected from the input.

*Epec Oy reserves all rights for improvements without prior notice*

**7.3 Functional block diagram**

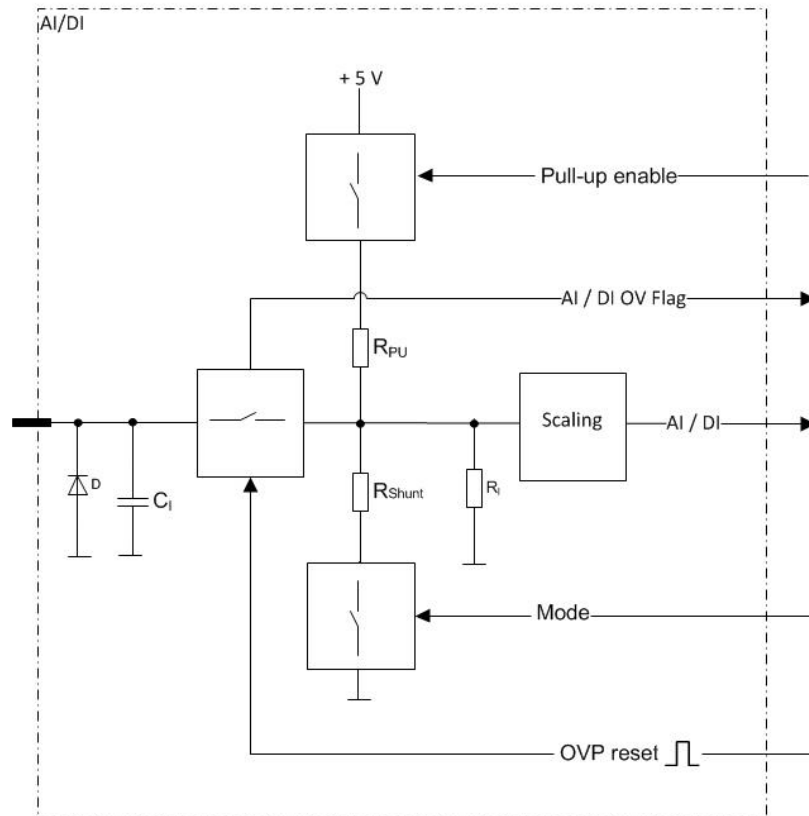

*Epec Oy reserves all rights for improvements without prior notice*

## 8 DI

- This type of pin is a ground referenced input (DI)
- This type of pin has no configurable features

### Electrical characteristics

Symbol	Parameter	Conditions	Min	Max	Units
$R_i$	Input Resistance	Referenced to GND	typ. 44		k $\Omega$
$V_{IH}$	Input High Voltage level	(Note 1, 3)	4,2	36	V
$V_{IL}$	Input Low Voltage level	(Note 3)	0	3,4	V
$V_{I-max}$	Max Input voltage	(Note 2)	-0,5	43	V
$C_i$	Input pin capacitance		typ. 1		nF

**Note 1:** Exceeding the max values might cause damage to input.

**Note 2:** Overload conditions.

**Note 3:** Includes hysteresis. The input state is maintained until the second voltage limit is exceeded

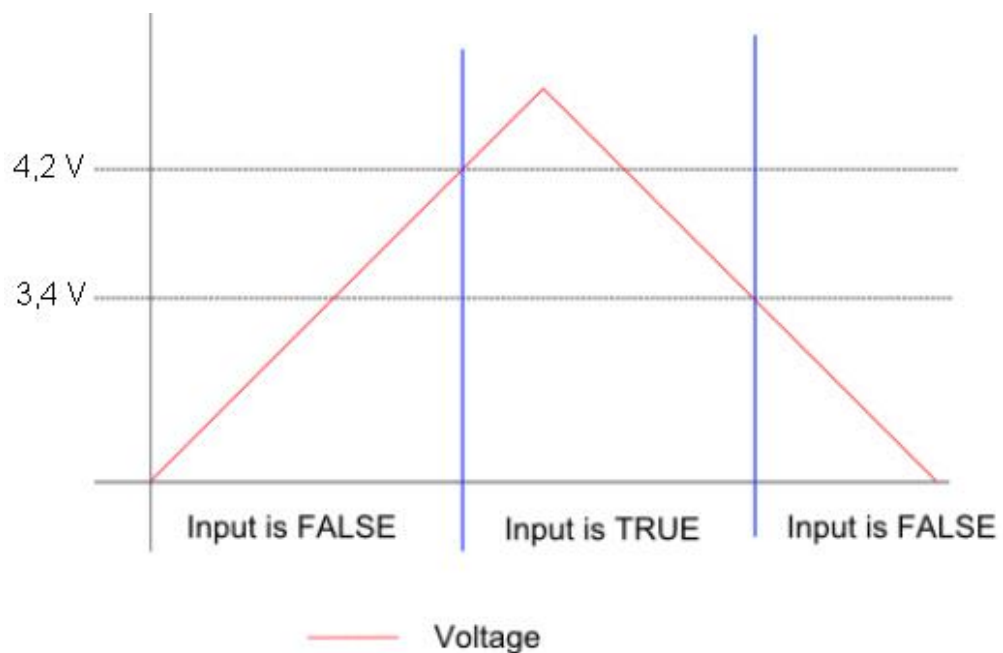

*Epec Oy reserves all rights for improvements without prior notice*

## 8.1 Functional block diagram

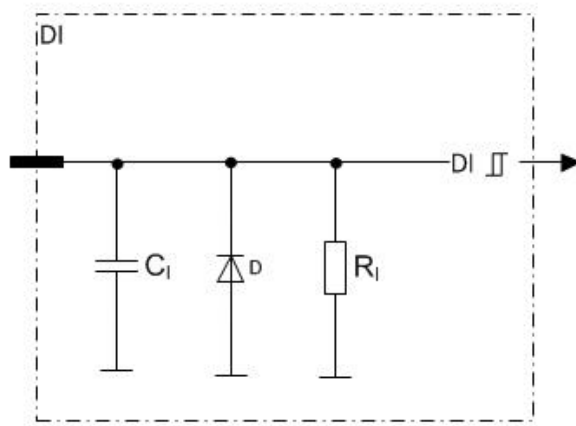

*Epec Oy reserves all rights for improvements without prior notice*

## 9 ACCELEROMETER (OPTION)

---

The accelerometer can be used to find out the control unit's

- position
- acceleration direction
- acceleration speed

<b>Measurement range, X-axis:</b>	±2 g
<b>Measurement range, Y-axis:</b>	±2 g
<b>Measurement range, Z-axis:</b>	±2 g
<b>Related programming libraries:</b>	Accelerometer.lib (For more information, see <i>Epec Programming and Libraries manual</i> )

*Epec Oy reserves all rights for improvements without prior notice*

## 10 +5 V REF

- This is an internally regulated and monitored reference voltage supply for external devices.
- This reference output can be switched on/off by application.

### 10.1 Protection features

- Overcurrent
- External voltage protection
- Errors are indicated with a fault signal

### 10.2 Voltage monitoring

The level of the output voltage can be monitored by application.

#### *Electrical characteristics*

Symbol	Parameter	Conditions	Min	Max	Units
$V_{o-level}$	Output voltage	Output On; Unconnected pins	typ. 5		V
$R_o$	Output Resistance	Output On		2	$\Omega$
$I_o$	Nominal Output Current	Output On;	0	100	mA
$I_{o-lim}$	Internal Current Limitation	Output On (Note 2, 3)	typ. 500		mA
$I_{o-sc}$	Short-circuit Current Limit	Output On; Overcurrent, $R_L = 0$	typ. 350		mA
$C_o$	Output Capacitance		typ. 47		$\mu$ F
	Fault-signal overvoltage threshold level	External overvoltage conditions	typ. 5,7		V
$V_{I-max}$	Max Input voltage	Overload conditions (Note 1)	0	36	V
Voltage monitoring					
$V_i$	Nominal Voltage measuring range		0	7	V
	Scaling Factor	(Note 4)	typ. 0,5		V/V

**Note 1:** When output voltage is under overload conditions, for example, short circuit to supply voltages. Exceeding the max value might cause damage to output.

**Note 2:** Current limit for overcurrent protection to limit internal power dissipation.

**Note 3:** When the limit is exceeded, the output current is regulated. In regulation, the output is switched into overcurrent mode.

**Note 4:** The measurement is scaled down before the conversion. The effect is compensated in Epec software libraries. For more information, see *Epec Programming and Libraries* manual.

*Epec Oy reserves all rights for improvements without prior notice*

**10.3 Functional block diagram**

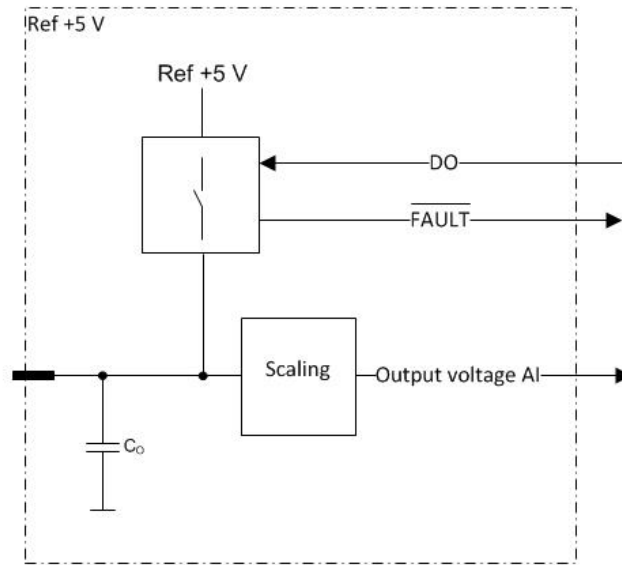

*Epec Oy reserves all rights for improvements without prior notice*

## 11 POWER SUPPLY

- Nominal supply voltage 12/24 VDC
- Operating range 8,4...36 VDC
- Undervoltage reset  $\leq 8$  VDC

### 11.1 Overvoltage Protection

- Max. 70 V continuous (Stresses above this value may cause permanent damage to the unit.)
- The unit has a shutdown circuit which protects the unit and loads against overvoltage. The shutdown circuit cuts off the power feed for the logic and loads in case of overvoltage. The shutdown circuit is activated when voltage exceeds circa 36,8 V. Power feed is restored when supply voltage drops under 36,8 V.

### 11.2 Power Consumption

- Supply voltage ( $U_m$ ) maximum continuous current 6 A (with full external load)
- GND current sum max 6 A

In this unit, there is only one power supply pin (X1.23). The ground pin (X1.22) is the recommended pin for the power supply return line. The following table shows the power supply pin locations.

#### Power supply pins

Designation	Connector / pin number	Potential
Supply voltage (for logic and power)	X1.23	+12/+24 VDC (8,4...36 VDC)
Ground (for supply voltage)	X1.22	GND
Data ground (for CAN, RS-232)	X1.9 X1.10	GND
AI ground	X1.18	GND (max current is 100 mA)
I/O ground	X1.19	GND
Supply outputs		
Reference supply (for external devices)	X1.16	+5 VDC / max 100 mA



Always use an external fuse to protect the unit. The fuse is needed for reverse voltage and overload protection. For more information, see section [Power Supply Cabling](#).

*Epec Oy reserves all rights for improvements without prior notice*

**Electrical characteristics**

Symbol	Parameter	Conditions	Min	Max	Units
$V_I$	Nominal Input Voltage		8,4	36	V
$V_{I-Load-dump}$	Max Input Transient Voltage Level	(Note 1)		123	V
$V_{I-max}$	Max Continuous Input Voltage Level	(Note 2)	-20	70	V
$V_{I-ovp}$	Overvoltage Threshold Level		typ. 37		V
$V_{I-uvp}$	Undervoltage Threshold Level		typ. 8		V
Supply voltage monitoring					
$V_{I-range}$	Nominal Input Voltage measuring range		0	36	V

**Note 1:** Load dump protection according to ISO7636-2: 2004 pulse 5,  $U_s = +123$  V

**Note 2:** Limited functionality when the voltage is higher than the nominal. If the voltage is less than 7,7 V, the unit is in non-operational state.

*Epec Oy reserves all rights for improvements without prior notice*

## 12 INTERFACES

### 12.1 CAN Bus



This manual describes the full hardware version. Some of the features are optional and not implemented in all hardware versions.

<b>Supported CAN amount:</b>	2-6 (Hardware Specific)
<b>Bit rate:</b>	All interfaces support bit rates 50, 125, 250, 500,1000 kbit/s
<b>CAN interface features:</b>	<ul style="list-style-type: none"> <li>• Implementations of higher layer protocols are user programmable. Epec provides implementations for CANopen and SAE J1939 as PLCopen libraries.</li> <li>• The physical interface of CAN is according to ISO 11898 and CAN 2.0B protocol</li> <li>• 11-bit and 29-bit message receive and transmit are supported</li> <li>• Transmitting of remote frames is supported in all CAN interfaces</li> </ul>
<b>Cabling instructions:</b>	See section <i>CAN Bus Cabling</i>

#### 12.1.1 CAN bus connection pins

The CAN1 communication pins are located in the control unit's AMP23 (X1) connector as follows:

Picture	Pin	Signal
	7	CAN1 L
	8	CAN1 H
	9	GND (DATA GROUND)
	10	GND (DATA GROUND)

The CAN2 communication pins are located in the control unit's AMP23 (X1) connector as follows:

Picture	Pin	Signal
	13	CAN2 L
	14	CAN2 H
	9	GND (DATA GROUND)
	10	GND (DATA GROUND)

*Epec Oy reserves all rights for improvements without prior notice*

The CAN3 communication pins are located in the control unit's AMP23 (X1) connector as follows:

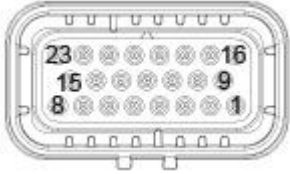
Picture	Pin	Signal
	1	CAN3 L
	2	CAN3 H
	9	GND (DATA GROUND)
	10	GND (DATA GROUND)

The CAN4 communication pins are located in the control unit's AMP23 (X1) connector as follows:

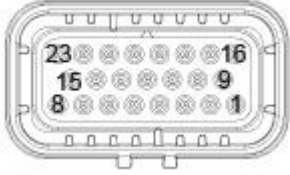
Picture	Pin	Signal
	5	CAN4 L
	6	CAN4 H
	9	GND (DATA GROUND)
	10	GND (DATA GROUND)

The CAN5 communication pins are located in the control unit's M12 (X5) connector as follows:

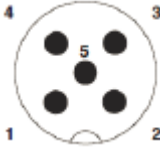
Picture	Pin	Signal
	1	CAN shield
	2	NC
	3	GND
	4	CAN5 H
	5	CAN5 L

The CAN6 communication pins are located in the control unit's M12 (X6) connector as follows:

Picture	Pin	Signal
	1	CAN shield
	2	NC
	3	GND
	4	CAN6 H
	5	CAN6 L

*Epec Oy reserves all rights for improvements without prior notice*

## 12.2 RS-232

<b>Supported RS-232 amount:</b>	1
<b>Mode:</b>	DTE (data terminal equipment)
<b>Cabling:</b>	See section <i>RS-232 Cabling</i>
<b>Related programming libraries:</b>	<ul style="list-style-type: none"> <li>Serial.library (For more information, see <i>Epec Programming and Libraries manual</i>)</li> <li>3S SysCom.library (For more information, see <i>3S CODESYS manual</i>)</li> </ul>

The serial bus communication pins are located in the control unit's X1 (AMP23) connector as follows:

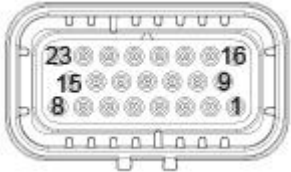
Picture (AMP23 male connector, front)	Pin	Signal
	3	TXD, transmit data
	4	RXD, receive data
	9	GND (DATA GROUND)
	10	GND (DATA GROUND)

*Epec Oy reserves all rights for improvements without prior notice*

## 12.3 USB



The USB port is intended for service use only.

USB ports provide a flexible way to attach peripheral devices. However, it should be noted that the core of the unit is based on embedded processor architecture. Therefore, it is strongly recommended to consult Epec to assess the compatibility with the product when selecting a new USB device.

<b>Supported USB amount:</b>	1
<b>Cabling instructions:</b>	See section <i>USB Cabling</i>
<b>Ordering USB cable:</b>	See section <i>Accessories and Ordering Codes</i>
<b>Related programming libraries:</b>	6000UsbDrive.library (For more information, see <i>Epec Programming and Libraries manual</i> )

### M12 miniB-USB

<b>Bus speed maximum:</b>	480 Mbps (high speed USB)
<b>Features:</b>	<ul style="list-style-type: none"> <li>• Recommended for updating CODESYS application</li> <li>• Recommended for updating firmware</li> <li>• Only host mode supported</li> </ul>

### X2, M12 connector (miniB-USB):

Picture	Pin	Signal
	1	+5 V (max 500 mA)
	2	D-
	3	D+
	4	ID
	5	GND

*Epec Oy reserves all rights for improvements without prior notice*

## 12.4 Ethernet



Firewall can be activated for Ethernet, for more information refer to *Epec Programming and Libraries manual*.

<b>Supported Ethernet amount:</b>	max 2
<b>Bus speed:</b>	Maximum 10/100 Mbps
<b>Cabling instructions:</b>	See section <i>Ethernet Cabling</i>
<b>Ordering Ethernet cables:</b>	See section <i>Accessories and Ordering Codes</i>

### X3, M12 connector (8 pin FEM, ethernet):

Picture	Pin	Signal
	1	RD2+
	2	TD2+
	3	TD2-
	4	RD1-
	5	TD1+
	6	RD1+
	7	RD2-
	8	TD1-

*Epec Oy reserves all rights for improvements without prior notice*

## 12.5 Cellular GSM/UMTS/LTE



This manual describes the full hardware version. Some of the features are optional and not implemented in all hardware versions.



Make sure SIM card slot is properly closed to ensure tightness protection.

SIM slot cover is tightened with two Torx TX6 M2x4 (DIN 965) screws. Switch off system power when changing the SIM card.



Firewall can be activated for the modem, for more information refer to *Epec Programming and Libraries Manual*.

<b>SMA connector in the unit:</b>	2 x RP-SMA female
<b>SMA connector type for antenna:</b>	2 x RP-SMA male *
<b>SMA tightening torque:</b>	brass: 0,3 – 0,6 Nm steel: 0,8 – 1,1 Nm
<b>Supported frequencies:</b>	Global coverage: <ul style="list-style-type: none"> <li>• B1/B2/B3/B4/B5/B7/B8/B12/B13/B18/B19/B20/B25/B26/B28@LTE-FDD</li> <li>• B38/B39/B40/B41@LTE-TDD</li> <li>• B1/B2/B4/B5/B6/B8/B19@WCDMA</li> <li>• 850/900/1800/1900MHz@GSM</li> </ul>
<b>SIM card size:</b>	Mini-SIM (2FF)
<b>SIM requirements:</b>	Switch off the PIN code request
<b>SIM card slot type:</b>	Push-push
<b>Ordering antenna:</b>	See section <i>Accessories and Ordering Codes</i>
<b>Related programming libraries:</b>	Modem.library (For more information, see <i>Epec Programming and Libraries manual</i> )

\*) Recommended to use Plantec Planar Combination Antenna K98LLVR (for using other antenna types, additional testing is required)

*Epec Oy reserves all rights for improvements without prior notice*

Correct SIM card position and antenna connector location:

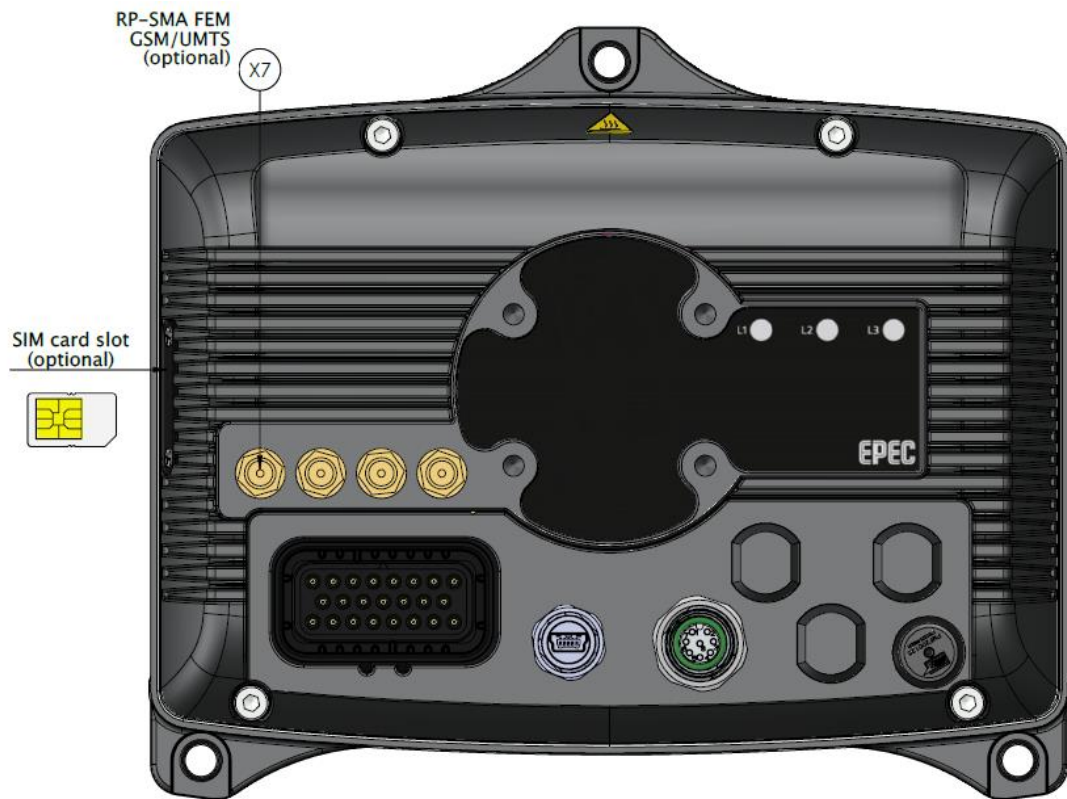

*Epec Oy reserves all rights for improvements without prior notice*

## 12.6 WLAN



This manual describes the full hardware version. Some of the features are optional and not implemented in all hardware versions.



A Firewall can be activated for the WLAN. For more information, refer to *Epec Programming and Libraries Manual > Programming > Programming 6000 Series Units > Using Firewall (6000 Series)*.



Electrostatic-sensitive connector (WLAN SMA connector tested with +/- 2 kV direct contact discharge)  
Higher voltage levels may cause disturbance to the unit.

<b>SMA connector type in device:</b>	SMA female
<b>SMA connector type for antenna:</b>	SMA male *
<b>SMA tightening torque:</b>	brass: 0,3 – 0,6 Nm steel: 0,8 – 1,1 Nm
<b>Encryption</b>	WPA
<b>Standard Conformance</b>	802.11 ac/a/b/g/n
<b>Supported frequencies:</b>	2,4 GHz
<b>Ordering antenna:</b>	See section <i>Accessories and Ordering Codes</i> *
<b>Related programming libraries:</b>	WLAN.library (For more information, see <i>Epec Programming and Libraries manual</i> )

\*) Recommended to use Plantec Planar WLAN Antenna M70XFR (Antenna Gain -3.0 dBi) (for using other antenna types, additional testing is required)

*Epec Oy reserves all rights for improvements without prior notice*

Correct antenna connector location:

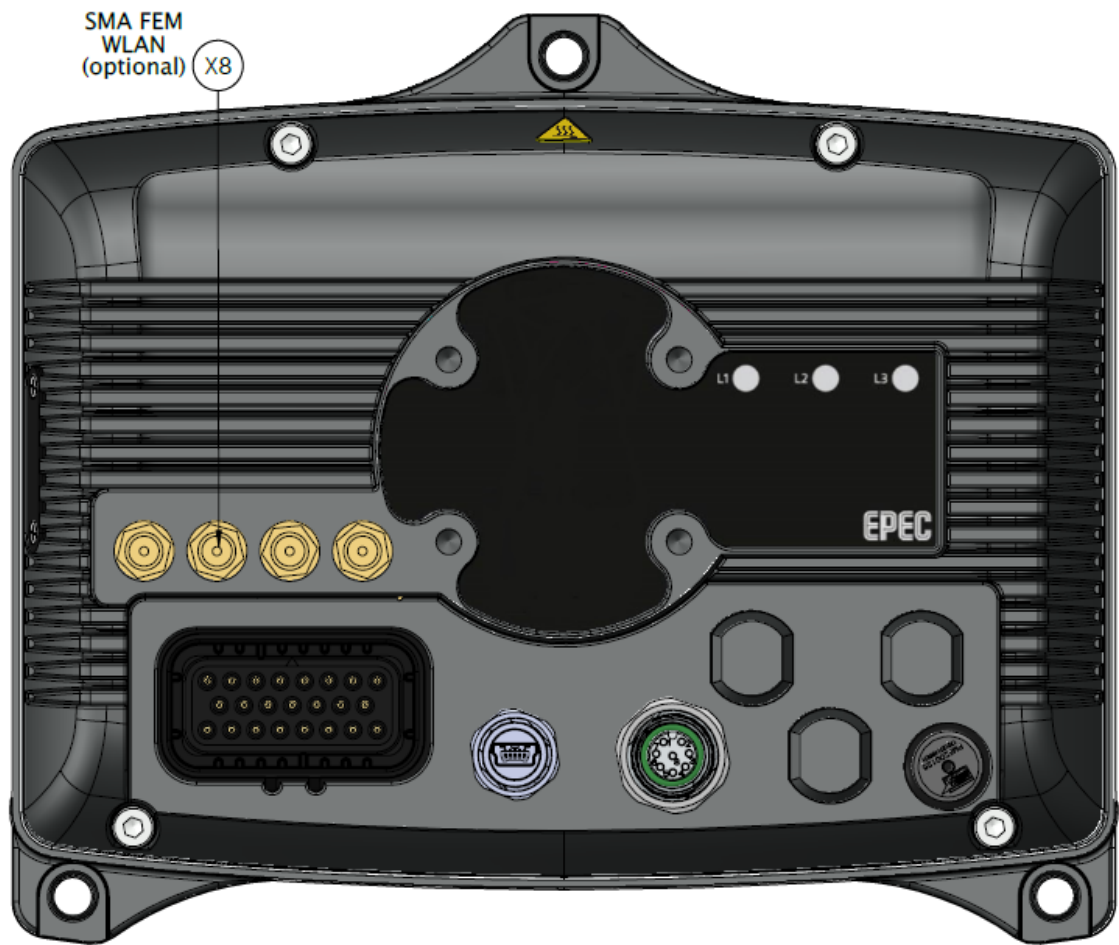

*Epec Oy reserves all rights for improvements without prior notice*

## 12.7 GPS/GLONASS



This manual describes the full hardware version. Some of the features are optional and not implemented in all hardware versions.

In addition to positioning, GPS can be utilized for example for fetching the UTC time for the unit's real-time clock.

<b>SMA connector in the unit:</b>	SMA female
<b>SMA connector type for cable:</b>	SMA male *
<b>SMA tightening torque:</b>	brass: 0,3 – 0,6 Nm steel: 0,8 – 1,1 Nm
<b>Antenna:</b>	It is recommended to use active antenna *
<b>Internal power supply for active antenna:</b>	2,85 V
<b>Max current for active antenna:</b>	10 mA
<b>Ordering antenna:</b>	See section <i>Accessories and Ordering Codes</i> *
<b>Related programming libraries:</b>	GPS.library (For more information, see <i>Epec Programming and Libraries manual</i> )

\*) Recommended to use Plantec Planar Combination Antenna K98LLVR (for using other antenna types, additional testing is required)

*Epec Oy reserves all rights for improvements without prior notice*

Antenna connector location:

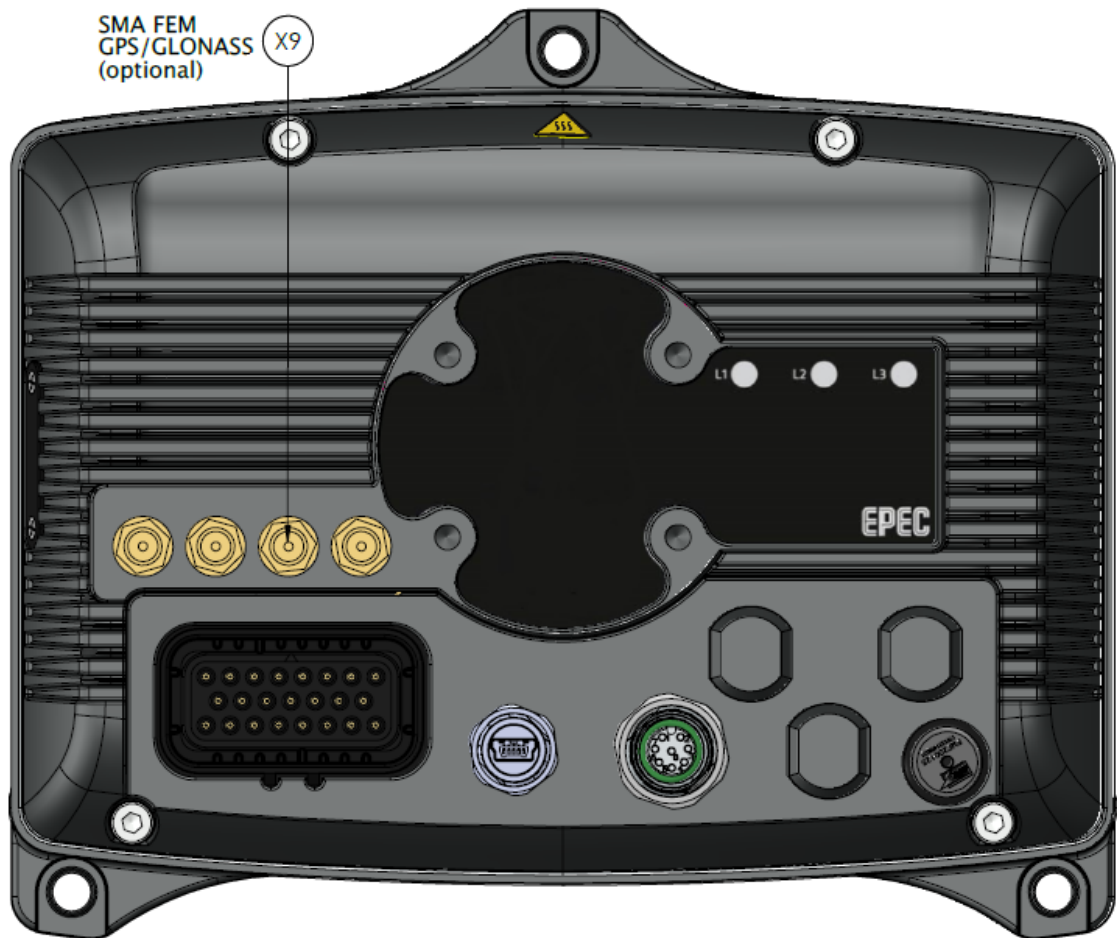

*Epec Oy reserves all rights for improvements without prior notice*

## 12.8 LTE Diversity



This manual describes the full hardware version. Some of the features are optional and not implemented in all hardware versions.



4G versions support LTE/WCDMA Rx-diversity. Rx-diversity function is enabled by default.

<b>SMA connector in the unit:</b>	RP-SMA female
<b>SMA connector type for antenna:</b>	RP-SMA male *
<b>SMA tightening torque:</b>	brass: 0,3 – 0,6 Nm steel: 0,8 – 1,1 Nm
<b>Supported frequencies:</b>	Global coverage: <ul style="list-style-type: none"> <li>• B1/B2/B3/B4/B5/B7/B8/B12/B13/B18/B19/B20/B25/B26/B28@LTE-FDD</li> <li>• B38/B39/B40/B41@LTE-TDD</li> </ul>
<b>Ordering antenna:</b>	See section <i>Accessories and Ordering Codes</i> *

\*) Recommended to use Plantec Planar Combination Antenna K98LLVR (for using other antenna types, additional testing is required)

*Epec Oy reserves all rights for improvements without prior notice*

The correct antenna connector location:



*Epec Oy reserves all rights for improvements without prior notice*

## 13 INTERNAL DIAGNOSTICS

### 13.1 Temperature and Voltage Monitoring

#### 13.1.1 Temperature Monitoring

This unit has an internal temperature sensor for monitoring the unit's internal temperature.

The temperature information is useful for self-diagnostic purposes and safety features.

##### *PCB Area Temperature*

Symbol	Parameter	Conditions	Min	Max	Unit
$T_{PCB}$	Nominal PCB Temperature measuring range		-55	+125	°C
$T_{PCB-err}$	Temperature Measurement Error	-40 .. +100 °C		+/- 6	% (FS)
		-55.. +125 °C		+/- 9	% (FS)
<b>Diagnostics</b>			<b>Low</b>	<b>High</b>	<b>Unit</b>
	Recommended warning levels		-30	+80	°C

##### *Processor Core Temperature*

Symbol	Parameter	Conditions	Min	Max	Unit
$T_{Core}$	Nominal Core Temperature measuring range		-40	+125	°C
<b>Diagnostics</b>			<b>Low</b>	<b>High</b>	<b>Unit</b>
	Recommended warning levels		-30	+80	°C
	Lowering CPU clock frequency to half	Non-configurable		+95	°C
	Shut-down	Non-configurable		+100	°C

#### 13.1.2 Supply Voltage Monitoring

Supply voltage of the control unit can be monitored.

Symbol	Parameter	Conditions	Min	Max	Unit
$U_{in}$	Nominal Supply Voltage measuring range		0	36	V
<b>Diagnostics</b>			<b>Low</b>	<b>High</b>	<b>Unit</b>
	Recommended supply voltage warning level		9	30	V

For additional electrical characteristics refer to section [Power Supply](#).

*Epec Oy reserves all rights for improvements without prior notice*

## 13.2 LED Indicator

Three LEDs are situated on the connector side of the unit. LED2 and LED3 are user programmable; refer to *Epec Programming and Libraries Manual* for more information.

LED1 is described in this chapter. The LED1 indicator is the left LED, according to the following image:

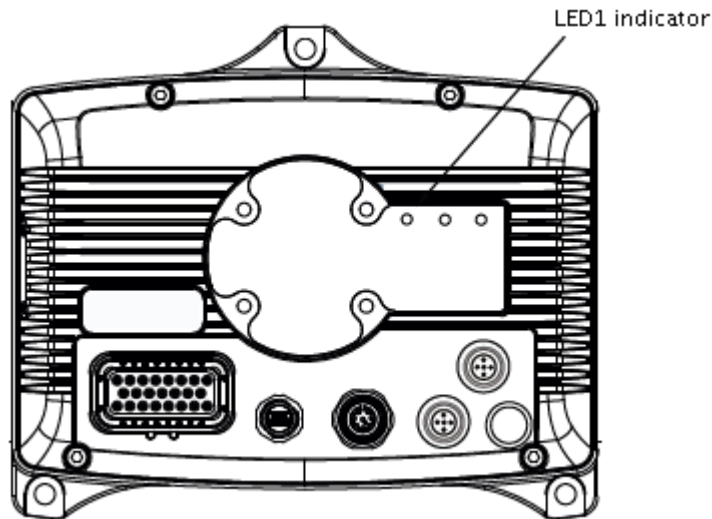

Some of the states must be implemented by using the EXT programming library. For more information about the EXT programming library, refer to *Epec Programming and Libraries Manual*.

The LED has green and red indicators and they indicate different operating conditions according to the following table:

LED State	LED 1	Implemented in device firmware or hardware	Implement by using in device CODESYS runtime or code template	Explanation
OFF	-	X		No supply voltage
Power ON	Red LED is constantly ON	X		Supply voltage is on, software is not running.
Booting-up	Yellow LED is constantly ON	X		System is starting up.

*Epec Oy reserves all rights for improvements without prior notice*

Booted	Yellow LED is blinking	X		There is no application or runtime. ApplicationLoader has nothing to start-up.
CODESYS runtime status	Green LED is constantly ON		X	CODESYS application stopped or update is in progress
CODESYS application status	Green LED blinks 2 times/second		X	CODESYS application running and SystemOk TRUE
CODESYS application status	Red LED blinks 2 times/second		X	CODESYS application running and SystemOk FALSE
No CODESYS Application	Green LED blinks 5 times/second		X	CODESYS runtime is running, no PLCopen application
Rescue	Blue LED constantly ON	X		Rescue is initializing
Firmware update	Red/Green LEDs blink alternately	X		Firmware update in progress
Application Exception	Red LED constantly ON		X	Application exception, for example, division by zero.

*Epec Oy reserves all rights for improvements without prior notice*

### 13.3 + 5 V REF Diagnostics

The +5 V reference supply has two diagnostics checks:

- analog output voltage monitoring and
- dedicated digital fault-signal

Both can be used to indicate overload and overvoltage situations. The diagnostics are independent from each other.



For fastest and most reliable error detection, it is recommended to use both output voltage monitoring and fault-flag diagnostics to detect errors.

#### 13.3.1 OVERLOAD

The diagnostics can detect overcurrent situation. The fault-signal is activated when excessive current is taken from the output. The output current is regulated when internal current limit is reached. The regulation current is always smaller than the limit. Current regulation causes the output voltage to drop with increasing load. This can be detected, using the output voltage monitoring feature, by setting a minimum (low) value limit for the output voltage.

With large enough loads, the output voltage drops to 0,1 V and the output current is limited to  $I_{o-sc}$  value to protect the output from overheating. This is indicated by the fault-signal. The fault-signal is deactivated, when the error source is removed by decreasing the load (and reducing the output current below  $I_{o-sc}$  value ) or when the output is turned off.



It is recommended to turn off the output when fault-signal becomes active.

#### 13.3.2 OVERVOLTAGE

Overvoltage event caused by an external source can be detected by using a combination of the diagnostic features. The fault-signal is activated when pin voltage goes above the fault-signal overvoltage threshold level. If the output voltage monitoring value is above nominal and/or the fault-signal is active, it can be determined that an external voltage source is connected to the output pin.

The output pin is protected against external voltages, but it is not recommended to connect external voltage sources to this pin.



In case of a limit violation, the output should be disabled as soon as possible. The unit can handle short term errors, but long term (e.g. several hours) exposures should be avoided with application/system design. Long term exposure to overvoltage or overload can cause permanent damage to the unit.

*Epec Oy reserves all rights for improvements without prior notice*

## 14 APPROVALS AND SAFETY

### 14.1 EMC Tests

Epec 6200 units are tested according to EMC tests that are described in this section.

The following tables provide a summary of performed EMC tests:

Measurement / test	Reference standard
Conducted Emissions from the Mains Cable	EN 55032:2015
Radiated Emissions	EN 55032:2015
Electrostatic Discharge Immunity	EN 61000-4-2:2009
Radiated RF-field Immunity	EN 61000-4-3:2006, A1:2008, A2:2010
Electrical Fast Transient	EN 61000-4-4:2012
Surge Immunity	EN 61000-4-5:2014
Conducted RF-field Immunity	EN 61000-4-6:2009

Measurement / test	Reference standard
Conducted Emissions	ISO 7637-2:2004, Amendment 1:2008
Radiated Emissions	CISRP 25:2002, Corrigendum 2004
Immunity to Electromagnetic Radiation	ISO 11452-2:2004 ISO 11452-4:2005, Corrigendum 1:2009
Conducted Transient Immunity	ISO 7637-2:2004, Amendment 1:2008

*Epec Oy reserves all rights for improvements without prior notice*

## 14.2 RF Tests

Epec 6000 series units comply with Radio Equipment Directive (2014/53/EU).

Epec 6200 units are tested according to following RF requirements:

Measurement / test	Reference standard
Radiated spurious emissions — MS allocated a channel	EN 301 511 V12.5.1
Radiated Emissions (UE)	EN 301 908-1 V11.1.1
Transmitter unwanted spurious emissions in the spurious domain	EN 300 328 V2.1.1
Global navigation satellite system (GNSS)	EN 303 413 V1.1.1
Transmitter unwanted emissions outside the 5 GHz RLAN bands	EN 301 893 V2.1.1
Common technical requirements, Broadband data transmission systems, Receive only mobile earth stations, Cellular communication mobile and portable radio	EN 301 489-1 V2.1.1, -17 V3.1.1, -19 V2.1.0, -52 V1.1.0
Information and Communication Technology Equipment – Safety	IEC 62368-1:2014

*Epec Oy reserves all rights for improvements without prior notice*

The following tables provide more detailed descriptions about the performed EMC tests:

Emission tests according to the E/ECE Regulation No. 10, Revision 5 (2012)									
Radiated disturbance emission test	<ul style="list-style-type: none"> <li>Test method E/ECE Reg. No. 10, Annexes 7 and 8, CISPR 25</li> </ul> <table border="1" data-bbox="818 510 1374 763"> <thead> <tr> <th>Frequency (MHz)</th> <th>Limit value (dBmV/m)</th> </tr> </thead> <tbody> <tr> <td>30 - 1000</td> <td>62/52/63 (Broadband QP)</td> </tr> <tr> <td>30 - 1000</td> <td>52/42/53 (Narrowband AVE)</td> </tr> </tbody> </table>	Frequency (MHz)	Limit value (dBmV/m)	30 - 1000	62/52/63 (Broadband QP)	30 - 1000	52/42/53 (Narrowband AVE)		
Frequency (MHz)	Limit value (dBmV/m)								
30 - 1000	62/52/63 (Broadband QP)								
30 - 1000	52/42/53 (Narrowband AVE)								
Conducted disturbances emission test	<ul style="list-style-type: none"> <li>Test method E/ECE Reg. No. 10, Annex 10, ISO 7637-2: 2004/Amd.1:2008</li> </ul> <table border="1" data-bbox="818 918 1374 1164"> <thead> <tr> <th>Port</th> <th>Limit level (V)</th> </tr> </thead> <tbody> <tr> <td rowspan="2">12 V DC input</td> <td>+75</td> </tr> <tr> <td>-100</td> </tr> <tr> <td rowspan="2">24 V DC input</td> <td>+150</td> </tr> <tr> <td>- 450</td> </tr> </tbody> </table>	Port	Limit level (V)	12 V DC input	+75	-100	24 V DC input	+150	- 450
Port	Limit level (V)								
12 V DC input	+75								
	-100								
24 V DC input	+150								
	- 450								

*Epec Oy reserves all rights for improvements without prior notice*

## Immunity tests according to the E/ECE Regulation No. 10, Revision 5 (2012)

Immunity to transient disturbances conducted along supply lines test

- Test method E/ECE Reg. No. 10, Annex 10, ISO 7637-2: 2004/Amd.1:2008
- Performance criterion:

Pulse	Criterion
1	C
2a	A
2b	C
3a	A
3b	A
4	C (12 V) A (24 V)
5a	C

- 12 V input, Pulse:

Pulse	Pulse parameters
1	-150 V, $R_i$ 10 $\Omega$ , 5 s, 5000 pulses
2a	+112 V, $R_i$ 2 $\Omega$ , 200 ms, 5000 pulses
2b	+10 V, 500 ms, 10 pulses
3a	-220 V, 10/90 ms, 60 min
3b	+150 V, 10/90 ms, 60 min
4	$t_d$ 25 ms -6,0 V, 5 s -2,5 V, 10 pulses
5	$t_d$ 400 ms, $R_i$ 0,5 $\Omega$ , +70 V, 1 pulse

- 24 V input, Pulse:

Pulse	Pulse parameters
1	-600 V, $R_i$ 50 $\Omega$ , 5 s, 5000 pulses
2a	+112 V, $R_i$ 2 $\Omega$ , 200 ms, 5000 pulses
2b	+20 V, 500 ms, 10 pulses
3a	-300 V, 10/90 ms, 60 min
3b	+290 V, 10/90 ms, 60 min
4	$t_d$ 100 ms -12 V, 20 s -5 V, 10 pulses

*Epec Oy reserves all rights for improvements without prior notice*

	<table border="1"> <tr> <td data-bbox="820 239 919 320">5</td> <td data-bbox="919 239 1377 320"><math>t_d</math> 350 ms, <math>R_i</math> 1 <math>\Omega</math>, +123 V, 1 pulse</td> </tr> </table>	5	$t_d$ 350 ms, $R_i$ 1 $\Omega$ , +123 V, 1 pulse																		
5	$t_d$ 350 ms, $R_i$ 1 $\Omega$ , +123 V, 1 pulse																				
<p>Immunity of ESAs to electromagnetic radiation</p>	<ul style="list-style-type: none"> <li>• Test method E/ECE Reg. No. 10, Annex 9, ISO 11452-2</li> <li>• Performance criterion: A</li> </ul> <table border="1"> <thead> <tr> <th data-bbox="756 1494 956 1608">Specification</th> <th data-bbox="956 1494 1035 1608">Step</th> <th data-bbox="1035 1494 1147 1608">Dwell time</th> <th data-bbox="1147 1494 1342 1608">Frequency Range (MHz)</th> <th data-bbox="1342 1494 1441 1608">Test level</th> </tr> </thead> <tbody> <tr> <td data-bbox="756 1608 956 1722">Modulation AM80% 1 kHz</td> <td data-bbox="956 1608 1035 1722">5%</td> <td data-bbox="1035 1608 1147 1722">3 s</td> <td data-bbox="1147 1608 1342 1722">20-80</td> <td data-bbox="1342 1608 1441 1722">60 mA</td> </tr> <tr> <td data-bbox="756 1722 956 1836">Modulation AM80% 1 kHz</td> <td data-bbox="956 1722 1035 1836">2%</td> <td data-bbox="1035 1722 1147 1836">3 s</td> <td data-bbox="1147 1722 1342 1836">80-1000</td> <td data-bbox="1342 1722 1441 1836">30 V/m</td> </tr> <tr> <td data-bbox="756 1836 956 1919">PM 577/4600 <math>\mu</math>s</td> <td data-bbox="956 1836 1035 1919">1%</td> <td data-bbox="1035 1836 1147 1919">3 s</td> <td data-bbox="1147 1836 1342 1919">800-1000</td> <td data-bbox="1342 1836 1441 1919">30 V/m</td> </tr> </tbody> </table>	Specification	Step	Dwell time	Frequency Range (MHz)	Test level	Modulation AM80% 1 kHz	5%	3 s	20-80	60 mA	Modulation AM80% 1 kHz	2%	3 s	80-1000	30 V/m	PM 577/4600 $\mu$ s	1%	3 s	800-1000	30 V/m
Specification	Step	Dwell time	Frequency Range (MHz)	Test level																	
Modulation AM80% 1 kHz	5%	3 s	20-80	60 mA																	
Modulation AM80% 1 kHz	2%	3 s	80-1000	30 V/m																	
PM 577/4600 $\mu$ s	1%	3 s	800-1000	30 V/m																	

*Epec Oy reserves all rights for improvements without prior notice*

	PM 577/4600 $\mu$ s	1%	3 s	1000-2000	30 V/m
--	------------------------	----	-----	-----------	-----------

**Classification of functional status**

*Class A:*

All functions of a device/system perform as designed during and after exposure to disturbance.

*Class B:*

All functions of a device/system perform as designed during and after exposure to disturbance. However, one or more of them can go beyond specified tolerance. All functions return automatically to within normal limits after exposure is removed. Memory functions shall remain class A.

*Class C:*

One or more functions of a device/system do not perform as designed during exposure but return automatically to normal operation after exposure is removed.

*Class D:*

One or more functions of a device/system do not perform as designed during exposure and do not return to normal operation until exposure is removed and a device/system is reset by simple "operator/use" action.

*Class E:*

One or more functions of a device/system do not perform as designed during exposure and cannot be returned to operation without repairing the device/system.

*Epec Oy reserves all rights for improvements without prior notice*

<b>EN 61000-6-3 (2006), Amd. A1 (2010)</b> <b>Electromagnetic compatibility-generic emission standard</b> <b>part6-3: residential, commercial and light-industrial environments</b>									
Radiated disturbance emission test	<ul style="list-style-type: none"> <li>Test method EN 55032: 2015</li> </ul> <table border="1"> <thead> <tr> <th>Frequency (MHz)</th> <th>Limit value (dBmV/m)</th> </tr> </thead> <tbody> <tr> <td>30 – 1000</td> <td>30/37 (QP)</td> </tr> <tr> <td>1000 – 6000</td> <td>70/74 (QP)</td> </tr> </tbody> </table>	Frequency (MHz)	Limit value (dBmV/m)	30 – 1000	30/37 (QP)	1000 – 6000	70/74 (QP)		
Frequency (MHz)	Limit value (dBmV/m)								
30 – 1000	30/37 (QP)								
1000 – 6000	70/74 (QP)								
Conducted disturbance at main ports emission test	<ul style="list-style-type: none"> <li>Test method EN 55032: 2015</li> </ul> <table border="1"> <thead> <tr> <th>Frequency (MHz)</th> <th>Limit value (dBmV)</th> </tr> </thead> <tbody> <tr> <td>0,15 – 30</td> <td>66/56/60 (QP)</td> </tr> <tr> <td>0,15 – 30</td> <td>56/46/50 (AVE)</td> </tr> </tbody> </table>	Frequency (MHz)	Limit value (dBmV)	0,15 – 30	66/56/60 (QP)	0,15 – 30	56/46/50 (AVE)		
Frequency (MHz)	Limit value (dBmV)								
0,15 – 30	66/56/60 (QP)								
0,15 – 30	56/46/50 (AVE)								
Conducted disturbance at wired network ports	<ul style="list-style-type: none"> <li>Test method EN 55032: 2015</li> </ul> <table border="1"> <thead> <tr> <th>Frequency (MHz)</th> <th>Limit value (dBmV)</th> </tr> </thead> <tbody> <tr> <td>0,15 – 30</td> <td>84/74 (QP)</td> </tr> <tr> <td>0,15 – 30</td> <td>74/64 (AVE)</td> </tr> </tbody> </table>	Frequency (MHz)	Limit value (dBmV)	0,15 – 30	84/74 (QP)	0,15 – 30	74/64 (AVE)		
Frequency (MHz)	Limit value (dBmV)								
0,15 – 30	84/74 (QP)								
0,15 – 30	74/64 (AVE)								
<b>EN 61000-6-2 (2005)</b> <b>Electromagnetic compatibility-generic immunity standard</b> <b>part6-2: industrial environment</b>									
Conducted radio-frequency common mode immunity test	<ul style="list-style-type: none"> <li>Test method EN 61000-4-6</li> <li>Performance criterion A</li> </ul> <table border="1"> <thead> <tr> <th>Specification</th> <th>Port</th> <th>Test level</th> </tr> </thead> <tbody> <tr> <td rowspan="2">Frequency range 0,150-80 MHz, Modulation AM80% 1 kHz, Dwell time 2 s</td> <td>DC input port</td> <td>10 V<sub>RMS</sub></td> </tr> <tr> <td>Signal ports )</td> <td>10 V<sub>RMS</sub></td> </tr> </tbody> </table>	Specification	Port	Test level	Frequency range 0,150-80 MHz, Modulation AM80% 1 kHz, Dwell time 2 s	DC input port	10 V <sub>RMS</sub>	Signal ports )	10 V <sub>RMS</sub>
Specification	Port	Test level							
Frequency range 0,150-80 MHz, Modulation AM80% 1 kHz, Dwell time 2 s	DC input port	10 V <sub>RMS</sub>							
	Signal ports )	10 V <sub>RMS</sub>							
Radiated radio-frequency electromagnetic field immunity test	<ul style="list-style-type: none"> <li>Test method EN 61000-4-3</li> <li>Performance criterion A</li> </ul> <table border="1"> <thead> <tr> <th>Specification</th> <th>Range (MHz)</th> <th>Test level</th> </tr> </thead> <tbody> <tr> <td>Modulation</td> <td>80-1000</td> <td>10 V/m</td> </tr> </tbody> </table>	Specification	Range (MHz)	Test level	Modulation	80-1000	10 V/m		
Specification	Range (MHz)	Test level							
Modulation	80-1000	10 V/m							

*Epec Oy reserves all rights for improvements without prior notice*

	<table border="1"> <tr> <td>AM 80% 1 kHz, Dwell time 3s</td> <td>1000– 6000</td> <td>3 V/m</td> </tr> </table>	AM 80% 1 kHz, Dwell time 3s	1000– 6000	3 V/m							
AM 80% 1 kHz, Dwell time 3s	1000– 6000	3 V/m									
Electrical fast transient (EFT/B) immunity test	<ul style="list-style-type: none"> <li>• Test method EN 61000-4-4</li> <li>• Performance criterion B</li> </ul> <table border="1"> <thead> <tr> <th>Test pulse</th> <th>Port</th> <th>Test level</th> </tr> </thead> <tbody> <tr> <td rowspan="2">Repetition frequency 5 kHz, Duration 1 minute</td> <td>DC input port</td> <td>± 2,0 kV</td> </tr> <tr> <td>Signal ports</td> <td>± 1,0 kV</td> </tr> </tbody> </table>	Test pulse	Port	Test level	Repetition frequency 5 kHz, Duration 1 minute	DC input port	± 2,0 kV	Signal ports	± 1,0 kV		
Test pulse	Port	Test level									
Repetition frequency 5 kHz, Duration 1 minute	DC input port	± 2,0 kV									
	Signal ports	± 1,0 kV									
Surge Immunity	<ul style="list-style-type: none"> <li>• Test method EN 61000-4-5</li> <li>• Performance criterion B</li> </ul> <table border="1"> <thead> <tr> <th>Specification</th> <th>Port</th> <th>Path</th> <th>Test level</th> </tr> </thead> <tbody> <tr> <td rowspan="2">Pulses: 5 Repetition rate: 60 s</td> <td rowspan="2">DC Input port</td> <td>Line to Line</td> <td>± 0,5 kV</td> </tr> <tr> <td>Line to Ground</td> <td>± 1,0 kV</td> </tr> </tbody> </table>	Specification	Port	Path	Test level	Pulses: 5 Repetition rate: 60 s	DC Input port	Line to Line	± 0,5 kV	Line to Ground	± 1,0 kV
Specification	Port	Path	Test level								
Pulses: 5 Repetition rate: 60 s	DC Input port	Line to Line	± 0,5 kV								
		Line to Ground	± 1,0 kV								
Electrostatic discharge (ESD) immunity test	<ul style="list-style-type: none"> <li>• Test method EN61000-4-2</li> <li>• Performance criterion B</li> </ul> <table border="1"> <thead> <tr> <th>Discharge mode</th> <th>Test level (kVp)</th> </tr> </thead> <tbody> <tr> <td>Contact</td> <td>± 2, ± 4, ± 8 (Note 1)</td> </tr> <tr> <td>Indirect contact</td> <td>± 2, ± 4, ± 8</td> </tr> <tr> <td>Air</td> <td>± 2, ± 4, ± 8, ± 15</td> </tr> </tbody> </table> <p>Note 1: WLAN SMA connector tested with ± 2 kV</p>	Discharge mode	Test level (kVp)	Contact	± 2, ± 4, ± 8 (Note 1)	Indirect contact	± 2, ± 4, ± 8	Air	± 2, ± 4, ± 8, ± 15		
Discharge mode	Test level (kVp)										
Contact	± 2, ± 4, ± 8 (Note 1)										
Indirect contact	± 2, ± 4, ± 8										
Air	± 2, ± 4, ± 8, ± 15										
Power-frequency magnetic field immunity test	<ul style="list-style-type: none"> <li>• Test method EN61000-4-8</li> <li>• Performance criterion A</li> </ul> <table border="1"> <thead> <tr> <th>Discharge mode</th> <th>Test level</th> </tr> </thead> <tbody> <tr> <td>Vertical/Horizontal 50/60 Hz, 5 min</td> <td>30 A/m</td> </tr> </tbody> </table>	Discharge mode	Test level	Vertical/Horizontal 50/60 Hz, 5 min	30 A/m						
Discharge mode	Test level										
Vertical/Horizontal 50/60 Hz, 5 min	30 A/m										

*Epec Oy reserves all rights for improvements without prior notice*

Transients and surges in vehicular environment has required EN 301 489-1

- Test method ISO 7637-2
- Performance criterion:

Pulse	Criterion
1	C
2a	A
2b	C
3a	A
3b	A
4	C (12 V) A (24 V)

- 12 V input, Pulse:

Pulse	Pulse parameters
1	-150 V, $R_i$ 10 $\Omega$ , 5 s, 5000 pulses
2a	+112 V, $R_i$ 2 $\Omega$ , 200 ms, 5000 pulses
2b	+10 V, 500 ms, 10 pulses
3a	-220 V, 10/90 ms, 60 min
3b	+150 V, 10/90 ms, 60 min
4	$t_d$ 25 ms -6,0 V, 5 s -2,5 V, 10 pulses

- 24 V input, Pulse:

Pulse	Pulse parameters
1	-600 V, $R_i$ 50 $\Omega$ , 5 s, 5000 pulses
2a	+112 V, $R_i$ 2 $\Omega$ , 200 ms, 5000 pulses
2b	+20 V, 500 ms, 10 pulses
3a	-300 V, 10/90 ms, 60 min
3b	+290 V, 10/90 ms, 60 min
4	$t_d$ 100 ms -12 V, 20 s -5 V, 10 pulses

### Performance criteria for immunity tests

#### *Performance criterion A:*

The EUT shall continue to operate as intended during and after the test. No degradation of performance is allowed.

#### *Performance criterion B:*

*Epec Oy reserves all rights for improvements without prior notice*

The EUT shall continue to operate as intended after the test. However, moderate degradation of performance is allowed. No change of actual operating state or loss of memory functions is allowed.

*Epec Oy reserves all rights for improvements without prior notice*

Epec Oy  
Tiedekatu 6  
FIN-60320 Seinäjoki

Postal address  
PL/P.O.Box 194  
FIN-60101 Seinäjoki, Finland

Phone  
+358-(0)20-7608 111

Internet  
[www.epec.fi](http://www.epec.fi)

### 14.3 Environmental Tests

The following environmental tests have been performed to Epec 6200 units:

Temperature			
Test	Temperature	Duration/ Exposure time	Remarks
Cold IEC 60068-2-1 (2007-03), Test Ad	-30 °C	16 h	<ul style="list-style-type: none"> <li>1 °C/min</li> </ul>
Dry heat IEC 60068-2-2 (2007-07), Test Be	+60 °C	16 h	<ul style="list-style-type: none"> <li>1 °C/min</li> </ul>
Damp heat cycling IEC 60068-2-30 (2005-08), Test Db	+25 °C/+55 °C	24 h	<ul style="list-style-type: none"> <li>rel. humidity &gt;90 %</li> <li>cycle duration 24 h</li> <li>two test cycles</li> </ul>
Change of temperature IEC 60068-2-14 (2009-01) Test Nb	-40 °C/+70 °C	3h	<ul style="list-style-type: none"> <li>change time between temperatures 2,5 °C/min</li> <li>2 test cycles</li> </ul>
Mechanical resistance			
Test	Duration and direction	Remark	
Shock test IEC 60068-2-27 (2008-02) Test Ea	<ul style="list-style-type: none"> <li>pulse duration 6 ms</li> <li>500 impulses in six directions</li> </ul>	<ul style="list-style-type: none"> <li>half sine pulse shape</li> <li>peak acceleration 500 m/s<sup>2</sup></li> </ul>	
Vibration, random IEC 60068-2-64 (2008-04), Test Fh	<ul style="list-style-type: none"> <li>test duration 60 min in every three test direction</li> </ul>	<ul style="list-style-type: none"> <li>ASD-level 5 m<sup>2</sup>/s<sup>3</sup>, 10 ... 200 Hz</li> <li>ASD-level 1,0 m<sup>2</sup>/s<sup>3</sup>, 200 ... 500 Hz</li> <li>total spectral acceleration 3,54 grms</li> </ul>	
Tightness tests for IP67			
Test	Duration and procedure	Remark	
Water test for IPX7 according to IEC 60529	<ul style="list-style-type: none"> <li>immersion duration 30 minutes</li> <li>immersion depth 1000 mm</li> <li>water temperature +20 °C</li> </ul>	<ul style="list-style-type: none"> <li>no ingress of water noticed inside</li> <li>complies with the requirements stated for the protection class IPX7</li> </ul>	

*Epec Oy reserves all rights for improvements without prior notice*

## 14.4 Simplified EU Declaration of Conformity

Epec Oy hereby declares that this device is in compliance with Directive 2014/53/EU.

The full text of the EU declaration of conformity is available at the following internet address:

[http://extranet.epec.fi/Public/Declarations/Epec6200\\_4G\\_DeclarationOfConformity.pdf](http://extranet.epec.fi/Public/Declarations/Epec6200_4G_DeclarationOfConformity.pdf)

### 14.4.1 Frequency, mode and maximum transmitted power

Frequency	Mode	Maximum transmitted power (EIRP)
2,4 GHz: 2,412 – 2,472 GHz	802.11b, 802.11g, 802.11n (HT20):13 802.11n (HT40):9	19,99 dBm
850 MHz	GSM	33 dBm ± 2 dB
900 MHz	EGSM	33 dBm ± 2 dB
1800 MHz	DCS	30 dBm ± 2 dB
1900 MHz	PCS	30 dBm ± 2 dB
850 MHz (8-PSK)	GSM	27 dBm ± 3 dB
900 MHz (8-PSK)	EGS	27 dBm ± 3 dB
1800 MHz (8-PSK)	DCS	26 dBm ± 3 dB
1900 MHz (8-PSK)	PCS	26 dBm ± 3 dB
B1/B2/B4/B5/B6/B8/B19	WCDMA	24 dBm +1/-3 dB
B1/B2/B3/B4/B5/B7/B8/B12/B13/B18/B19/B20/B25/B26/B28	LTE-FDD	23 dBm ± 2
B38/B39/B40/B41	LTE-TDD	23 dBm ± 2

### 14.4.2 Country Limitations



Use of this radio equipment (WLAN) is not allowed in the geographical area within a radius of 20 km from the centre of Ny-Ålesund, Svalbard, Norway.

*Epec Oy reserves all rights for improvements without prior notice*

## 15 MECHANICS AND CABLING

### 15.1 Unit Dimensions

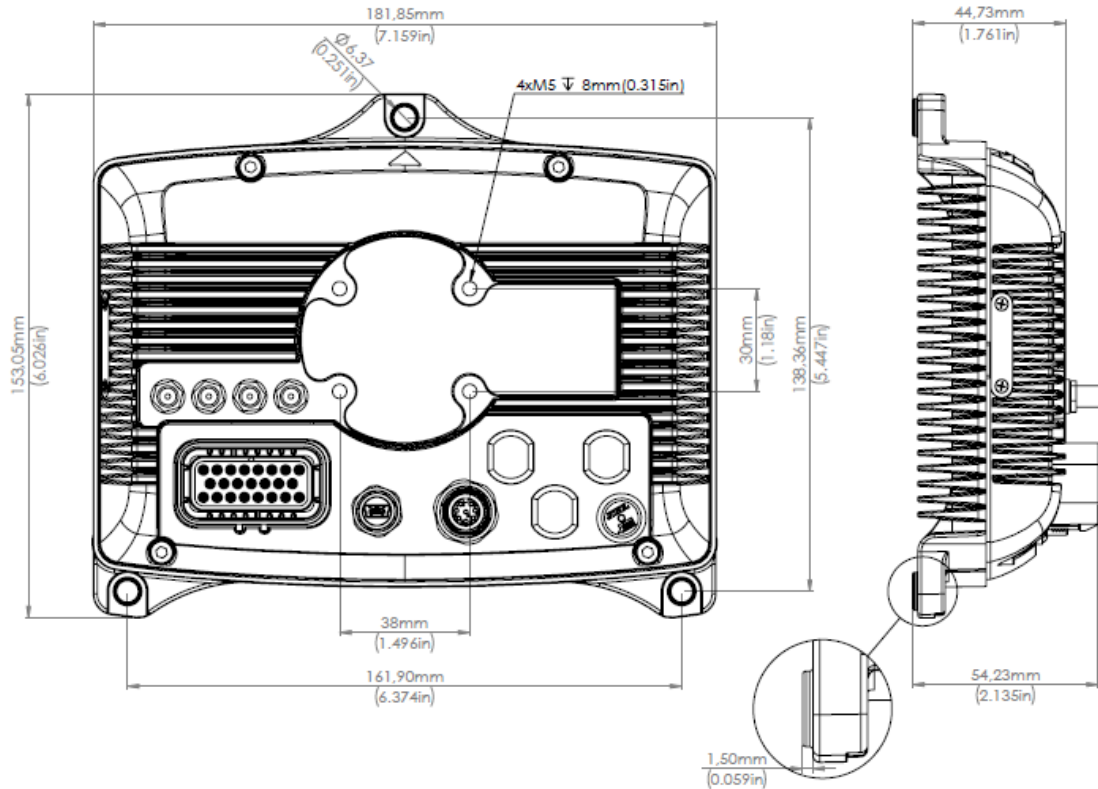

### 15.2 Mounting and Cleaning



It is required that the unit housing has a galvanic connection to machine frame.



Control unit mounting location should be planned so that the machine's washing does not damage the unit.

A direct water jet towards the control units should be avoided, especially when using high pressure. Also, the use of any such solvent that causes damage to electronic devices should be avoided when handling the control units.



When cleaning the control unit, do not use highly alkaline / acidic substances, too hot water, or too heavy mechanical abrasion.



In moist conditions, the unit must be mounted and oriented so that the connectors are not filled with water.

*Epec Oy reserves all rights for improvements without prior notice*



Make sure that all the unused connectors are sealed properly using the provided covers (sealing cap protection class is IP67).

- The mounting is done with 3 pieces of M6 screws to DIN 912
- It is possible to use a spring washer under the screw head
- Mounting is recommended to be done on to a conductive metal base. It is recommended that the control unit's aluminum housing has a galvanic connection to the machine frame
- The paint can be removed from the control unit under each screw head before mounting, to ensure a galvanic connection to the control unit frame. Also, the paint can be removed from the machine frame, where the control unit will be attached.
- 3-point mounting allows mounting on a slightly uneven surface
- Reserve 10 cm installation space for the connector cables
- Mounting position must be horizontal or vertical to allow water, etc. flowing away from connectors, see the figures below.

Do not mount the unit in a position where the connector side is facing upwards:

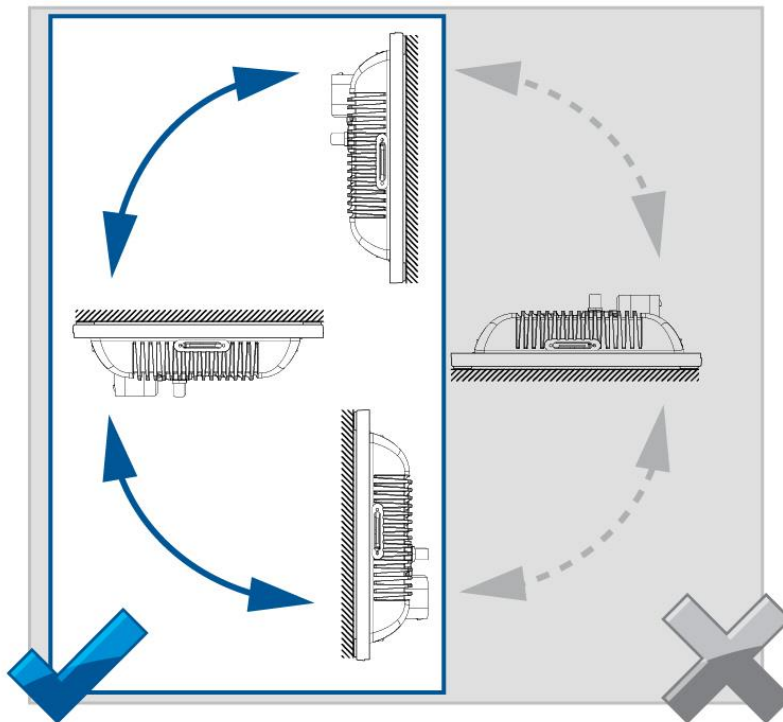

*Epec Oy reserves all rights for improvements without prior notice*

### 15.3 Plugging and unplugging the cables/connectors

Epec control units use heavy duty gold plated, locked and sealed AMPSEAL connectors. The following figure shows an example of an AMPSEAL connector:

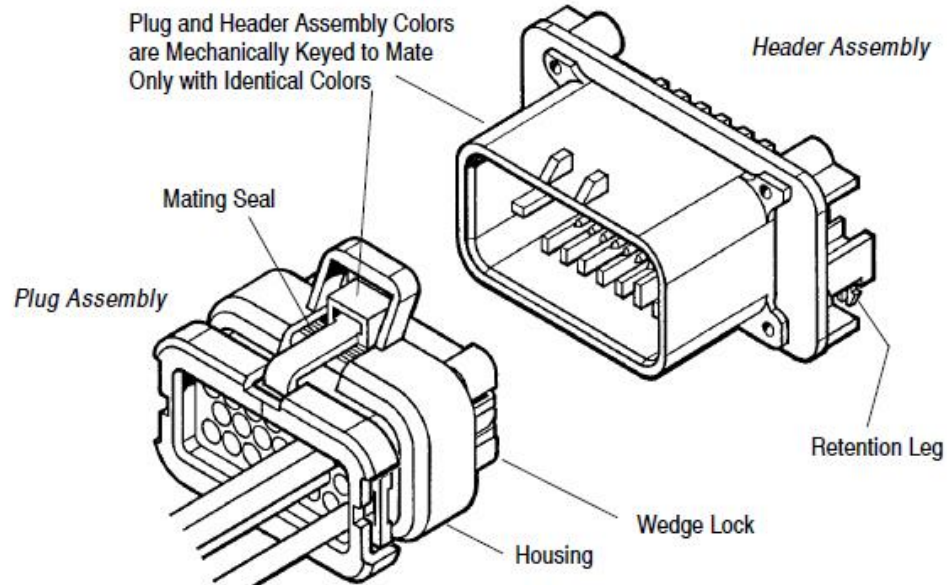

- Gold plated AMPSEAL connectors pack a current of 15 amperes per contact and tolerate operating temperature range.
- All module connectors are mechanically keyed to mate only with identical colors (blue, grey and black).



When connecting, make sure that:

- connectors are pressed down to the bottom and that they are locked
- connectors are clean (avoid moisture or dirt inside the connector)
- unused connectors are covered with empty connectors of the same color (this helps to keep the control unit connectors dry and protected)
- all cables, connectors and tools are of correct type, and sufficiently high quality, and suitable for this kind of use (protection for moisture, mechanical stability, power durability, coupling resistance among other things)
- there is a sufficient margin (slack) left in the cables to prevent the torsion of the connectors
- wires are bound to the control unit cover base knob with cable ties

*Epec Oy reserves all rights for improvements without prior notice*

The following figure describes some general instructions about the connectors.

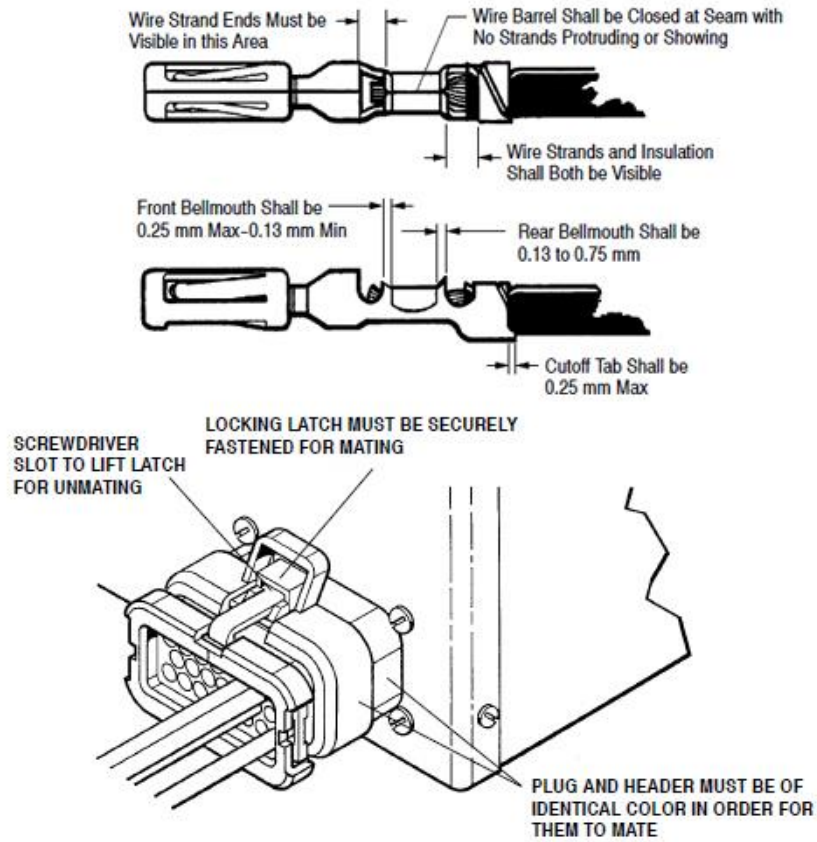

Refer to AMP Application Specification 114-16016 for more detailed information on connectors and cable recommendations.

Ordering codes for the AMPSEAL connectors, crimps and tools are listed in Section [Accessories and Ordering Codes](#).

*Epec Oy reserves all rights for improvements without prior notice*

## 15.4 Cabling

### 15.4.1 System Topologies



Generally, cabling should be properly designed and documented to help the initial assembly and maintenance.  
It is highly recommended to mark each cable on both ends to avoid confusion and errors.



The cables must be run in a safe route along the machine frame.  
When routing cables, avoid interfering objects and pay particular attention to moving parts of the machine.  
It is also good to minimize the amount of the connection points of the cable harness to maximize reliability.  
Also, all valid safety instructions should be observed when coupling.

- The control units are connected with each other using standardized CAN bus.
- The idea of the Epec embedded control system, is that all the control units are installed close to sensors, encoders and other equipment connected to them.
  - This way the amount of the traffic on the CAN bus is minimized and connections can be made using short wires.

#### 15.4.1.1 Termination resistors

- Generally, the bus cable is terminated at both ends with termination resistors (ISO 11898:1993).
- External termination resistor (120 Ω) has to be connected at both ends between CAN H and CAN L.
- 



The cable lengths presented here are approximates. Actual cable lengths also depend on the cable quality, the cable type and also on the machine environment (possible interference).

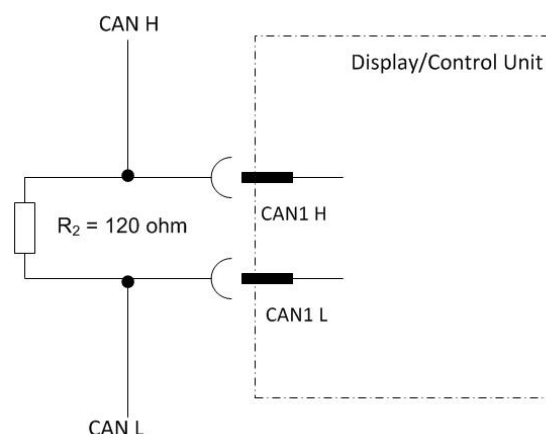

**Example1.** The figure shows a connection example of an external termination resistor in CAN1

*Epec Oy reserves all rights for improvements without prior notice*

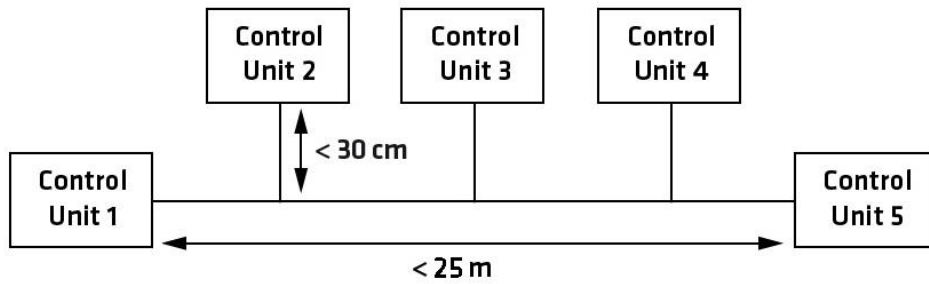

**Example 2.** Control system topology in theory with maximum bus speed (1000 kbit/s); Control Units in traditional bus arrangement. Termination resistor must be connected at control unit 1 and control unit 5. For more information about the bus speeds, refer to CiA DS-102 standard.

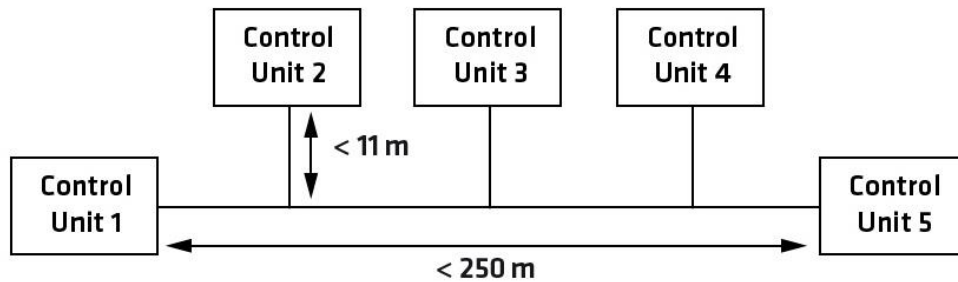

**Example 3.** Control system topology in theory with 250 kbit/s bus speed; Control Units in traditional bus arrangement. Termination resistor must be connected at control unit 1 and control unit 5. For more information about the bus speeds, refer to CiA DS-102 standard.



**Example 4.** The usage of the termination resistor (TR) in a conventional bus. The maximum recommended bus length is directly dependent on the bus speed. In theory, the maximum length with the maximum speed can be up to 25 meters. If the bus speed is lower, the length can be extended. The maximum length of the bus depends on the bus speed. For more information about the bus speeds, see the table below / refer to CiA DS-102 standard.

*Epec Oy reserves all rights for improvements without prior notice*

The following table shows some baud rates in general purpose CAN bus networks as well as the maximum bus length for a given baud rate, that CAN in Automation (CiA) international users and manufacturers group has recommended to be used. For more information, refer to CiA DS-102 standard.

***CAN bus baud rates and bus lengths according to CiA DS-102 standard***

Baudrate	Bus length
1 Mbits/s	25 m
800 kbits/s	50 m
500 kbits/s	100 m
250 kbits/s	250 m
125 kbits/s	500 m
50 kbits/s	1000 m

## 15.4.2 CAN Bus Cabling



The CAN bus cable is the neural backbone of the whole system and should be designed and constructed with extra care.

- For information about the CAN bus lengths and baud rates, refer to section [System Topologies](#).

### 15.4.2.1 Cable

- It is recommended to use high quality and twisted (approx. 1 round / 1 inch) CAN bus cable.
- Normal UTP (Unshielded Twisted Pairs) cable is well suited for distances under approximately 10 meters.
- In longer distances, and especially if there is possibility for electromagnetic interference, it is highly recommended to use shielded and twisted cable for CAN bus, also for shorter distances.
- To avoid electromagnetic interference (EMI), locate the bus cable as far away from high-current carrying cables as possible. Generally, the amount of the connections and connectors should be minimized to maximize security; also all connections should be done carefully.
- The shield grounding must be done only in one end of the cable

*Epec Oy reserves all rights for improvements without prior notice*

## 15.4.2.2 Cable shield

Connection example when there is a GND pin (X1.22) available in the control unit:

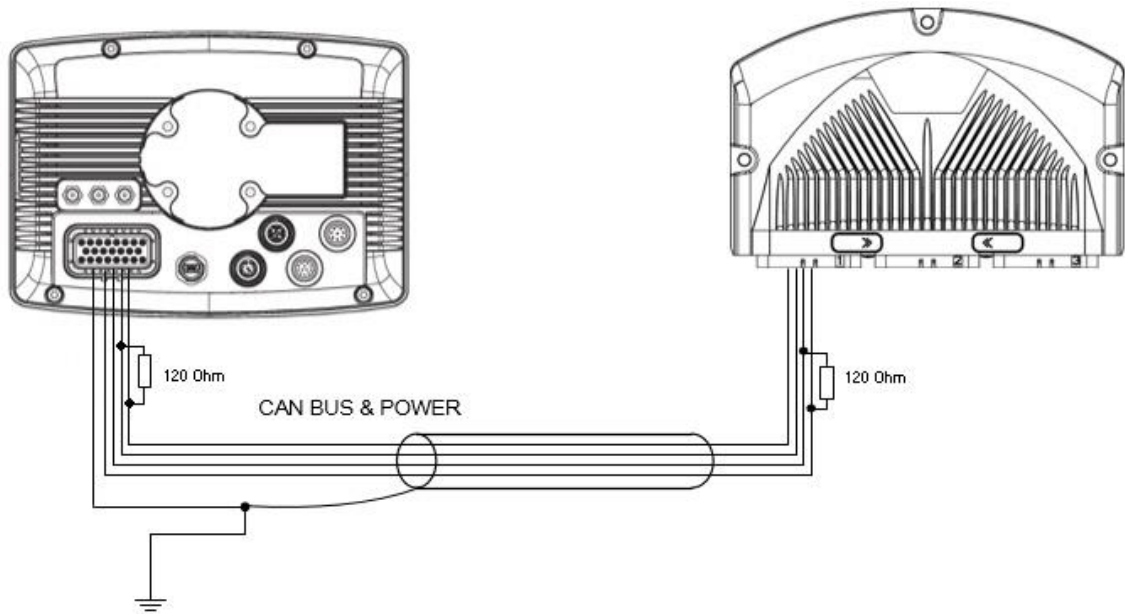

Connection example when there is not a GND pin available in the control unit:

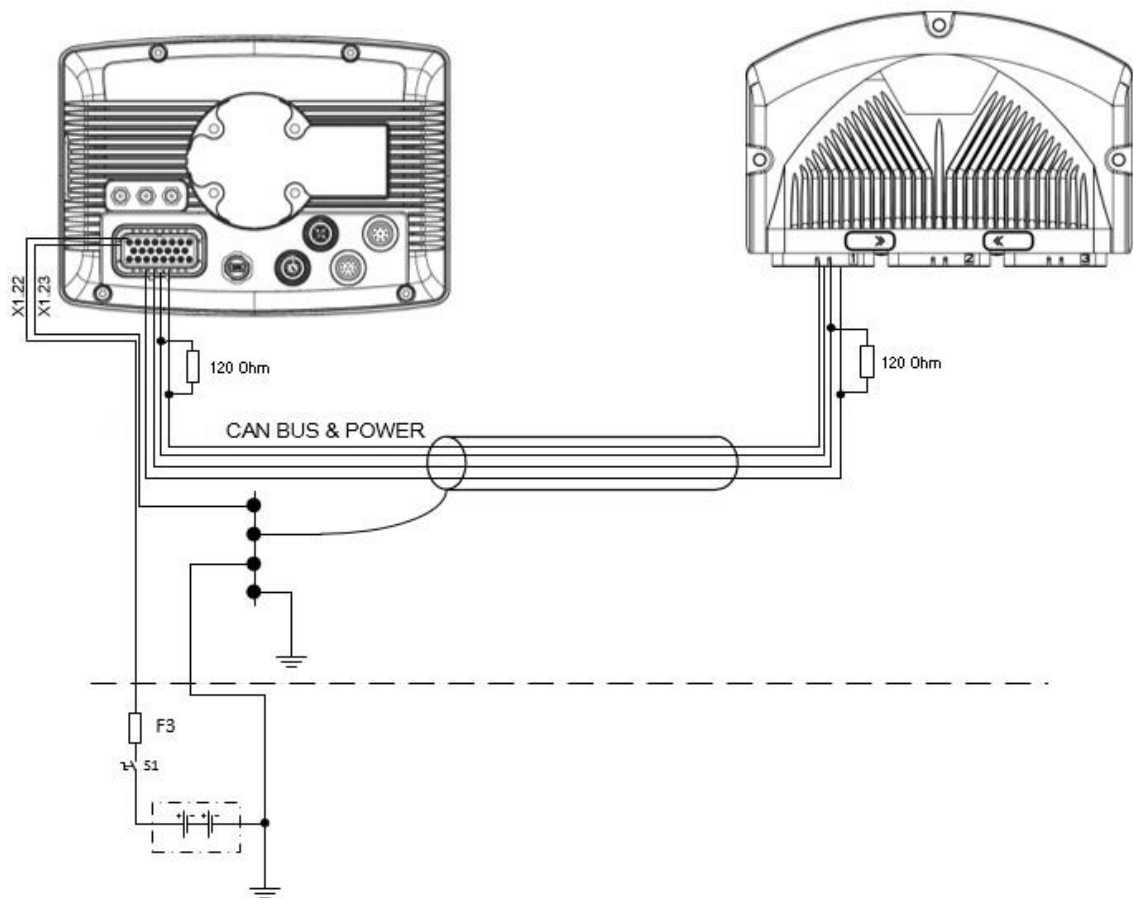

*Epec Oy reserves all rights for improvements without prior notice*

### 15.4.2.3 CAN cabling for system developers

The following figure describes cabling for CAN communication between Epec control units and a PC.

Ordering codes for the needed hardware are included in the figure.



An external termination resistor (120 Ω) has to be connected at both ends between CAN H and CAN L.

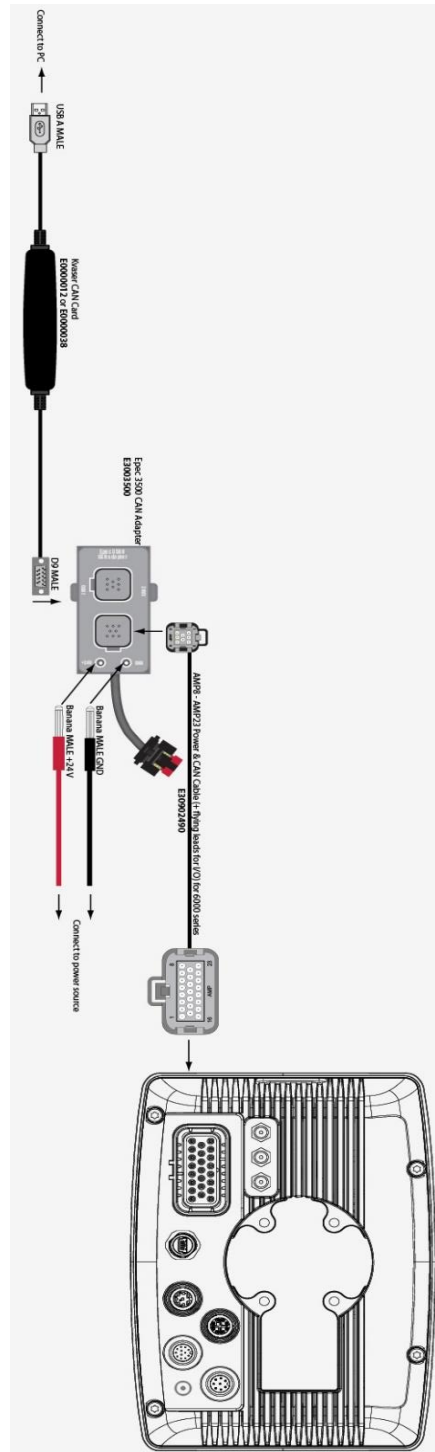

*Epec Oy reserves all rights for improvements without prior notice*

### 15.4.3 I/O Cabling



Closed circuit loops are always recommended and mandatory when you are using DO or PWM pin as an input.



To ensure correct measurement, reserve separate GND pin(s) for AI pin(s) and don't use it/them for any other purposes. See cabling example below.

- The cabling for encoders etc. is in many cases supplied together with them.
- In many cases, very simple basic cable may be used, e.g. automobile R2 cable (0,5 or 1,0) by NK Cables.
- Dimensions of the cable should be appropriate for AMP contacts (so that crimping is possible).
  - Refer to AMPSEAL table (in section [Accessories and Ordering Codes](#)) for dimensions.
  - Take extra care for protecting the cables against physical wear and damage.
- Only one wire can be connected to one AMPSEAL connector pin. However, if more than one wire has to be connected to one connector pin, it has to be connected by branch wiring.
- Some voltage inputs use relatively low voltages.
  - Consider using shielded cables for these encoders etc. especially for longer distances to increase safety
- Using shielded cable is recommended also in joystick connections.

The following figure describes four different ways to connect closed circuit loop through the control unit:

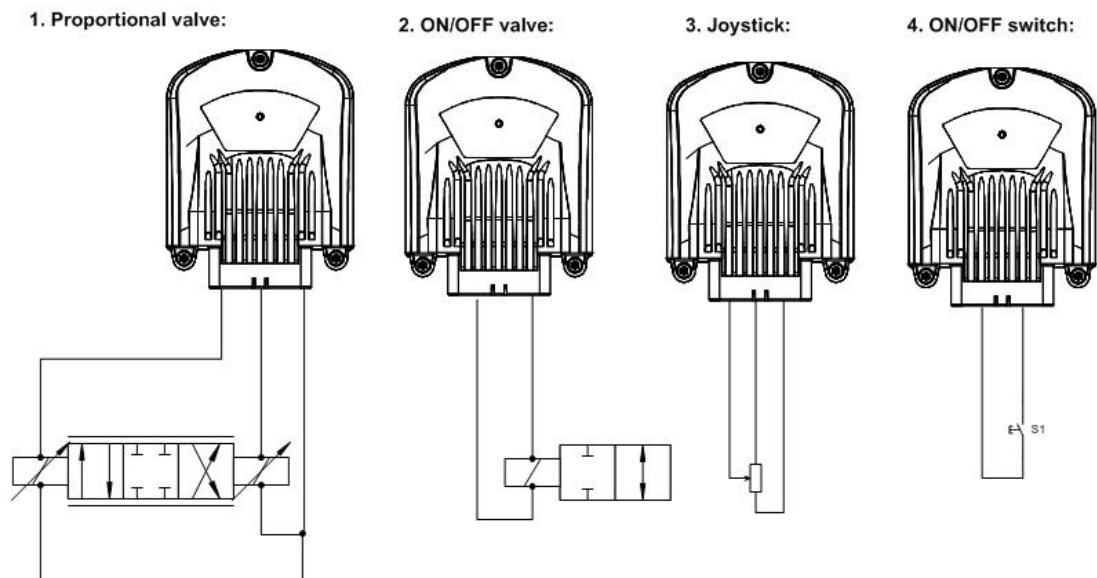

*Epec Oy reserves all rights for improvements without prior notice*

The following figure describes three different ways to connect open circuit loop (from the control unit's point of view):

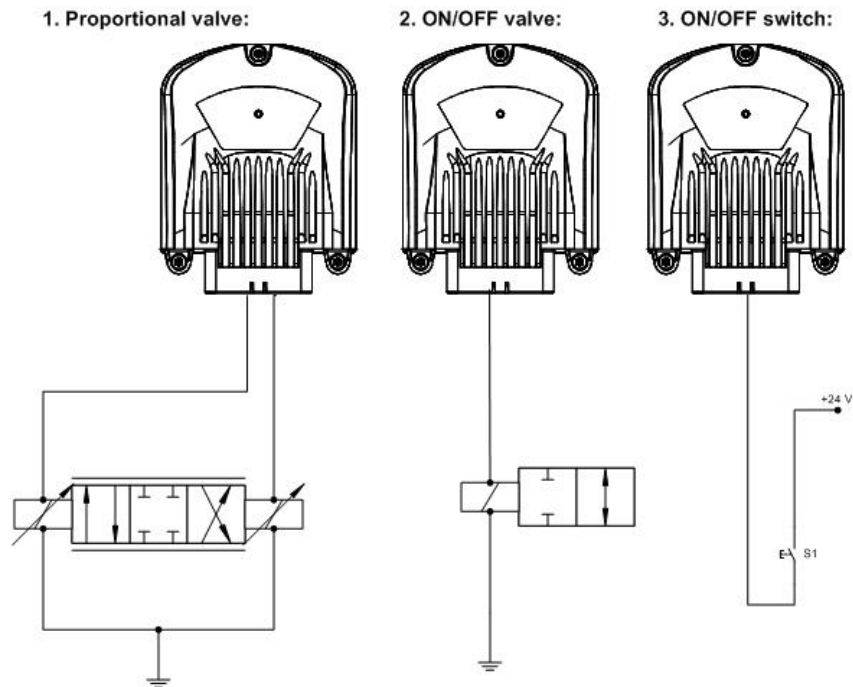

AI – GND cabling examples (use separate GND pin for AI pins):

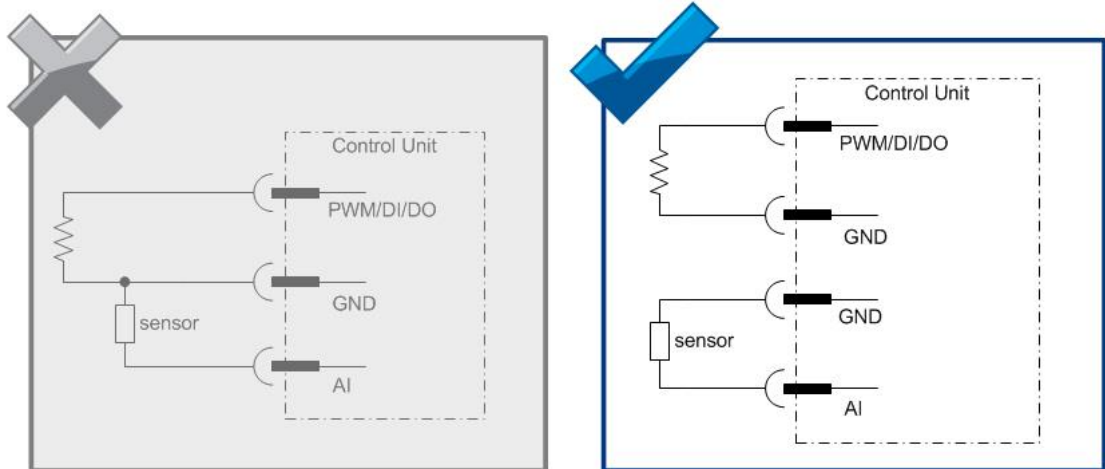

- sensors and encoders must be wired according to the closed-loop principle, i.e. the power for the sensors and encoders is supplied by the control unit they are connected to. This way, it is possible to avoid potential harmful differences, so the MOSFET driven output power switching operates properly.

When designing the sensor and encoder connections, observe single-point grounding. All Each control unit connector has several GND pins which should be used. Refer to section *Power Supply* for accurate pin allocation of connectors.

*Epec Oy reserves all rights for improvements without prior notice*

## 15.4.4 Ethernet Cabling



In order that the electromagnetic interference (EMI) would not affect the data transfer, the installation of the cable should be done as close as possible to the body of the machine.

It is recommended to wire the cable under the shelter of mechanical hits if the installation environment makes it possible.

The cable must be installed as far away as possible from other cables with high power.

The maximum length of a connection is 30 meters.

- This Ethernet connection is based on 10BASE-T/100BASE-T connection where two twisted pairs are used.
- M12 connector is not a standard connecting format and to get the best operation reliability the following issues should be considered in circuitry and installation; type of the used cable, connecting the cable and the installation method.

### 15.4.4.1 Cable

If the installation environment requires a cable that takes heat and low temperature, the minimum demand for the cable is under 20 m with connection Outdoor UTP Cat5E 4Pairs (Water Blocking / UV Resistant).

For longer connections it is recommended to use cable Outdoor UTP Cat6 4Pairs (Water blocking / UV Resistant), similar to it or better.

- (SFTP = Shielded Foiled Twisted Pair)
- (FTP = Foiled Twisted Pair)
- (STP = Shielded Twisted Pair)
- (UTP= Unshielded Twisted Pair)

#### Ethernet cable connection with Epec 6000 series unit:

M12 male connector (front)	M12 pin (Ethernet)	M12 pin (Ethernet 2)	RJ45 male pin	T568B Pair	Color (according to T568B standard)	RJ45 male connector (front)
	6 (rxd1+)	1 (rxd2+)	3 (rxd+)	3	White/green	
	5 (txd1+)	2 (txd2+)	1 (txd+)	2	White/orange	
	4 (rxd1-)	7 (rxd2-)	6 (rxd-)	3	Green	
	8 (txd1-)	3 (txd2-)	2 (txd-)	2	Orange	
			4	1	Blue	
			5	1	White/blue	
			7	4	White/brown	
			8	4	Brown	

*Epec Oy reserves all rights for improvements without prior notice*

**15.4.4.2 Ethernet cabling for system developers**

The following figure describes a cabling example for Ethernet communication between Epec control units and a PC. Ordering codes for the needed hardware are included in the figure.

To check 6000 series unit's IP addresses, use ApplicationLoader (device software). For more information, see *Epec Programming & Libraries Manual: Programming > Programming 6000 Series Units > Configuring Ethernet and DNS Settings* (available from Epec's Extranet).

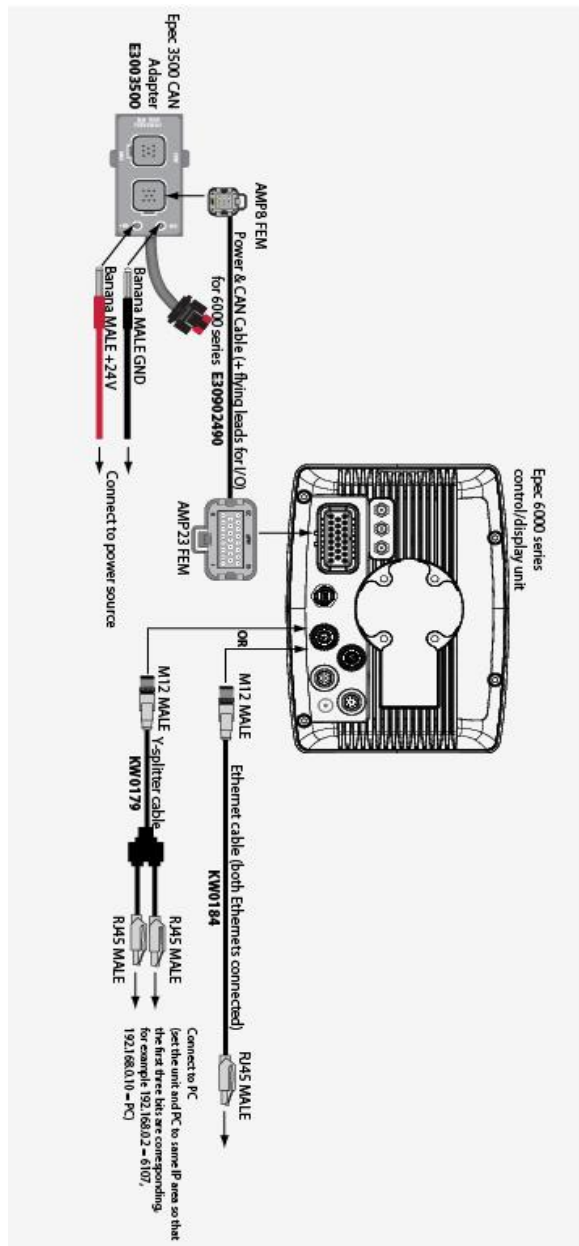

*Epec Oy reserves all rights for improvements without prior notice*

**15.4.5 RS-232 Cabling**

- Minimum requirement for creating the RS-232 data link is a 3-wire connection.
  - RX = Receive Data
  - TX = Transmit Data
  - GND = Signal Ground
- The maximum length of the cable is 3 m
- The following picture is an example of a connection between Epec 6000 series unit and PC with 3-wire connection.

**RS-232 cabling connection:**

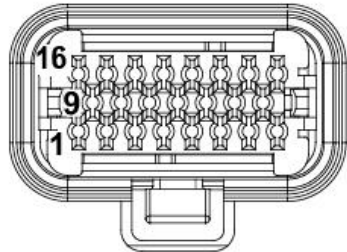
AMP23 female connector (front)	AMP23 pin
	3 (TXD, transmit data)
	4 (RXD, receive data)
	10 (GND)

**15.4.6 USB Cabling**

- It is recommended to use full speed rated USB cable.
- Full speed cable consists of twisted signal pairs, VBUS, GND and an overall shield.
- When using an appropriate cable, the operation reliability of the connected device is assured.
- The maximum length (2 m) of the used cable is determined of transit time delay, attenuation, communication speed and the power consumption of the connected device.
- In practise, it is not recommended to use longer cable than 1 m.
- The previous things should be considered when connecting the device directly to the USB connection.

**M12 miniB-USB**

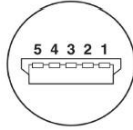
Picture	Pin	Signal
	1	+5V (max 500 mA)
	2	D-
	3	D+
	4	ID
	5	GND

*Epec Oy reserves all rights for improvements without prior notice*

### 15.4.7 Power Supply Cabling



The maximum continuous current per pin is 6 A.



The power for sensors, encoders and other equipment should be supplied from the very same unit that the equipment is connected to, to ensure the best performance of the system. No external power (or ground) connections are allowed.

- The nominal operating voltage for Epec control units is 12 and 24 VDC. The full operating range is 8,4...36 VDC
- See section [Power Supply](#) for accurate pin allocation of the connectors
- Single point grounding should be used for power supply for all the control units
- The type and parameters of the power supply fuse should be selected depending on the machine type and product use case

#### Power supply's wiring example:

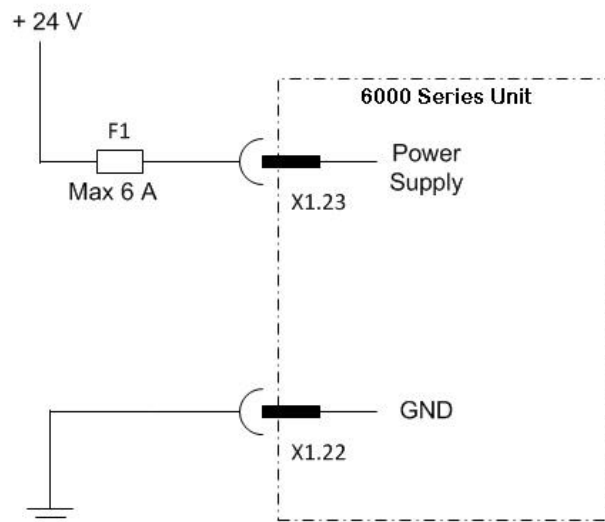

#### 15.4.7.1 Emergency Stop



In all European Community countries, the emergency stop should be implemented in accordance with standard EN ISO 13850, which complies to the EC Machinery directive 2006/42/EC. In other countries, the emergency stop should be implemented according to local standards and/or to local legislation.

*Epec Oy reserves all rights for improvements without prior notice*

#### 15.4.8 Antenna Installation



To avoid coexistence interference with 2,4 GHz WLAN and LTE (e.g. band 7) communication, a minimum distance of 70 cm should be maintained between LTE and WLAN antennas in all installations.



Due to potential coexistence interference in wireless communication, LTE/WLAN combination antenna is not recommended.

*Epec Oy reserves all rights for improvements without prior notice*

## 15.5 Welding



Welding causes some high current flows and voltage peaks in the machine. It should be noted that the electronics of the control system may be damaged, if the welding current can get through the control unit itself.

So, when welding, it should be taken care to prevent high currents from going through the control units or through the CAN bus.

Follow carefully the following instructions.



Disconnect all the connectors from the control units before welding.



Generally, even if the control system power is disconnected, welding should be done carefully and by following appropriate safety measures. Welding grounding should be connected close to the welding point to avoid long distance high current flow through machine frame.

*Epec Oy reserves all rights for improvements without prior notice*

## 15.6 Accessories and Ordering Codes



### 15.6.1 Related products

Picture	Product Name	Epec ordering code	Epec data sheet code
	3500 CAN Adapter Box	E3003500	MAN000385
	Epec Measuring Adapter	E3002014	MAN000387
	Ethernet Y-splitter cable 0,8 m	KW0179	MAN000585
	Ethernet cable 3 m	KW0184	MAN000585
	USB cable & Panel Mounting Adapter, 2 m Cable connectors: M12 USB mini-B – USB A male Adapter Connectors: USB A fem – USB A fem	E30902489	MAN000614
	USB cable (M12 USB mini-B – USB A male) 2 m	KW0186	MAN000614
	Ethernet Cable M12/M12	KW0209	MAN000585

*Epec Oy reserves all rights for improvements without prior notice*

	GSM UMTS / GPS antenna	KY0035	MAN000627
	MIMO LTE/GNSS Antenna	KY0044	MAN000720
	WLAN antenna	KY0037	MAN000687
	Camera (Brigade)	KH0038	MAN000626
	Camera cable (M12 FEM – Mini-DIN4 FEM) 30 m (for Brigade)	KW0201	MAN000626
	Camera Y- splitter cable (M12 FEM– 2 x M12 MALE) 1 m (for Brigade)	E30902496	MAN000626
	Small Mounting Pedestal	E30802473	MAN000578
-	M12 sealing cap for male connector (IP67)	KX0423	-
-	M12 sealing cap for female connector (IP67)	X0058261	-

*Epec Oy reserves all rights for improvements without prior notice*

	Power supply & CAN cable for 6000 series (AMP23 - AMP8 + 17 x flying leads) 2 m	E30902490	MAN000615
	Kvaser D-Sub Termination Adapter	E0000039	MAN000696
-	Kvaser CAN Card	E0000038	-

### 15.6.2 AMPSEAL Connectors

Epec uses gold plated, locked and sealed AMPSEAL heavy duty connectors for all Epec CAN Control Unit Family products to ensure endurance under extreme conditions.

- All connectors are mechanically keyed to mate only with identical colors

AMPSEAL product	TE Connectivity ordering code	Epec ordering code
Contact for AMP plug assembly	770854-3	KX0010
Crimping tool	58529-1	TT0018
AMP 23-pin Plug Assembly, Black	770680-1	KX0008
AMP 23-pin Plug Assembly, Black with 2 m leads	-	E30901311

### 15.6.3 AMPSEAL cable dimensions

Size		Insulation diameter range	Strip length ±0,4
mm <sup>2</sup>	AWG		
0,5	20	1,7 to 2,7	5,1
0,8	18		
1,4	16		
1,5	---	2,2 to 2,4	

Typical hand crimping tool e.g.: AMP Procrimper 58529-1 (TE Connectivity), Epec ordering code TT0018

*Epec Oy reserves all rights for improvements without prior notice*

16 GLOSSARY

---

**A**

**API:** Application Programming Interface

**B**

**Boot loader:** Boot loader is a software that is needed to load and run the device system. Epec boot loader cannot be updated by the customer.

**C**

**CAN:** Controller Area Network

**CANopen:** Communication protocol and device profile specification for embedded systems used in automation by CAN in automation (CiA) <http://www.can-cia.org/>

**CODESYS:** Controller Development System

**CPU:** Central Processing Unit

**E**

**ECC:** Error-correcting code memory

**F**

**Firmware:** Firmware is the device software programmed into memory contained in the hardware. Epec firmware can be updated by the customer, Epec firmware does not include boot loader.

**G**

**GFG:** Glass-Film-Glass. A touchscreen panel with a robust glass surface designed for harsh environmental conditions.

**GPS:** Global Positioning System

**H**

**HMI:** Human Machine Interface

**I**

**IP class:** Ingress Protection Rating, protection class. Classifies the degree of protection provided against the intrusion dust, water etc in mechanical casings and with electrical enclosures. It is published by the International Electrotechnical Commission (IEC).

**J**

*Epec Oy reserves all rights for improvements without prior notice*

**J1939:** SAE J1939 protocol Vehicle bus standard used for communication and diagnostics

## L

**LCD:** Liquid-Crystal Display. A display that uses liquid crystals' light modulating properties

**LED:** Light-Emitting Diode. A semiconductor light source used for example in lamps and displays.

## M

**MB:** Megabyte

## N

**NBR:** Nitrile Rubber

## O

**OVP:** Overvoltage Protection

## P

**PCAP:** Projected Capacitive Touch

**PCB:** Printed Circuit Board

**PLC:** Programmable Logic Controller

**PLCopen:** PLCopen is a global standard for industrial control programming. IEC61131

**PWM:** Pulse-Width Modulation

## R

**RTC:** Real-Time Clock

**RTR:** Remote Transmission Request

## S

**SIM:** Subscriber Identity Module. An integrated circuit that stores securely the international mobile subscriber identity (IMSI) and the related key. They are used for identifying and authenticating subscribers on mobile telephony devices

## T

**TFT:** Thin-Film-Transistor display. A display that uses thin-film transistor technology to improve image qualities such as addressability and contrast.

## U

*Epec Oy reserves all rights for improvements without prior notice*

**USB:** Universal Serial Bus. An industry standard developed to standardize the connection of computer peripherals.

**UTC:** Coordinated Universal Time

**UVP:** Undervoltage Protection

## **W**

**WVGA:** Wide Video Graphics Array. A display resolution with the same 480 pixel height as VGA but wider, such as 800×480 (5:3).

*Epec Oy reserves all rights for improvements without prior notice*