

# Sentronic<sup>LP</sup> IO-Link CLASS A | 617 Series

617 Series IO-Link CLASS A with Display and Controls  
Installation Manual

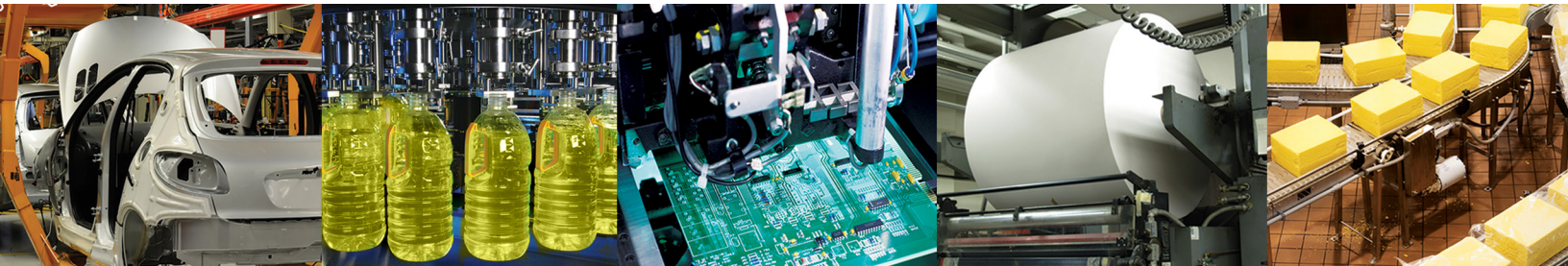

# Table of Contents

## Sentronic<sup>LP</sup>

<b>Description</b>	<b>2</b>
How To Order	2
Operating Elements	3
Manual Pressure Adjustment	3
Operating Modes	3
<b>Electrical Connection</b>	<b>4</b>
<b>Analog Target Value - Output Pressure</b>	<b>5</b>
<b>Pneumatic Connection</b>	<b>6</b>
<b>Information on the Factory Settings</b>	<b>6</b>
<b>Technical Characteristics</b>	<b>7</b>
Fluid Characteristics	7
Key Values	7
<b>Care and Maintenance</b>	<b>8</b>
<b>Dimensions and Weights</b>	<b>9</b>



**CAUTION**  
OBSERVE PRECAUTIONS  
FOR HANDLING  
ELECTROSTATIC SENSITIVE  
DEVICES

This product contains electronic components sensitive to electrostatic discharge. An electrostatic discharge generated by a person or object coming in contact with the electrical components can damage or destroy the product.

To avoid the risk of electrostatic discharge, please observe the handling precautions and recommendations contained in standard EN 100015-1. Do not connect or disconnect the device while it is energised.



**CAUTION!** Dangerous operating conditions may occur when using the programming interface on the valve as the valve may possibly not react to the analog setpoint any more.  
Provide for protection against uncontrolled movement of equipment when putting the valve into operation and before making any modifications to the valve settings.

We herewith declare that the version of the product described in this installation manual is intended to be incorporated into or assembled with other machinery and that it must not be put into service until the machinery into which it is to be incorporated has been declared in conformity with the provisions of Council Directive 2006/42/EC.

Handling, assembly and putting into service and all settings and adjustments must be done by qualified, authorised personnel only.



This product complies with the essential requirements of the EMC Directive 2014/30/EU and its amendments. It is CE-approved. A separate Declaration of Conformity is available on request.  
Please provide ordering code and serial numbers of products concerned.

## NOTICE

**The information in this manual is subject to change without notice.**

In no event shall ASCO NUMATICS be liable for technical or editorial errors or omissions. Neither is any liability assumed for accidental or consequential damages arising out of or in connection with the supply or use of the information contained herein.

**THIS MANUAL CONTAINS INFORMATION PROTECTED BY COPYRIGHT. NO PART OF THIS DOCUMENT MAY BE PHOTOCOPIED OR REPRODUCED IN ANY FORM OR MANNER WHATSOEVER WITHOUT PRIOR WRITTEN PERMISSION FROM ASCO NUMATICS.**

## Description

The Sentronic<sup>LP</sup> valve operates with pulsed pilot valves which change the pressure in a control chamber. A downstream flow amplifier (pressure booster) converts the control pressure into an output pressure. The output pressure is measured by a pressure sensor and fed to the integrated digital control circuit.

Sentronic<sup>LP</sup> is particularly suitable for pressure control procedures where a constant pressure is required with different flow rates, such as air dosing via nozzles or turbine rotation speed control.

Using the available DaS software (Data Acquisition Software), the valve can be adapted to the application if necessary.

- The pressure connections and the air vent connections are designed in the same size, which results in short response times both for increasing the pressure and for reducing the pressure.
- Digital pressure control in a closed circuit: An internal pressure sensor measures the output pressure. The output pressure is adjusted in real time.
- The control parameters can be changed with the additional DaS software. The variability of the parameters used by the valve is ensured by the DaS software. This flexibility makes it possible to adapt the valve to a very wide range of applications and to optimize the response time and the precision of the valve and prevent it from overshooting.
- After determining the optimum parameters, these can be saved for personal use in a project file, which can be sent into our Product Support Department for future series production.

## How to Order

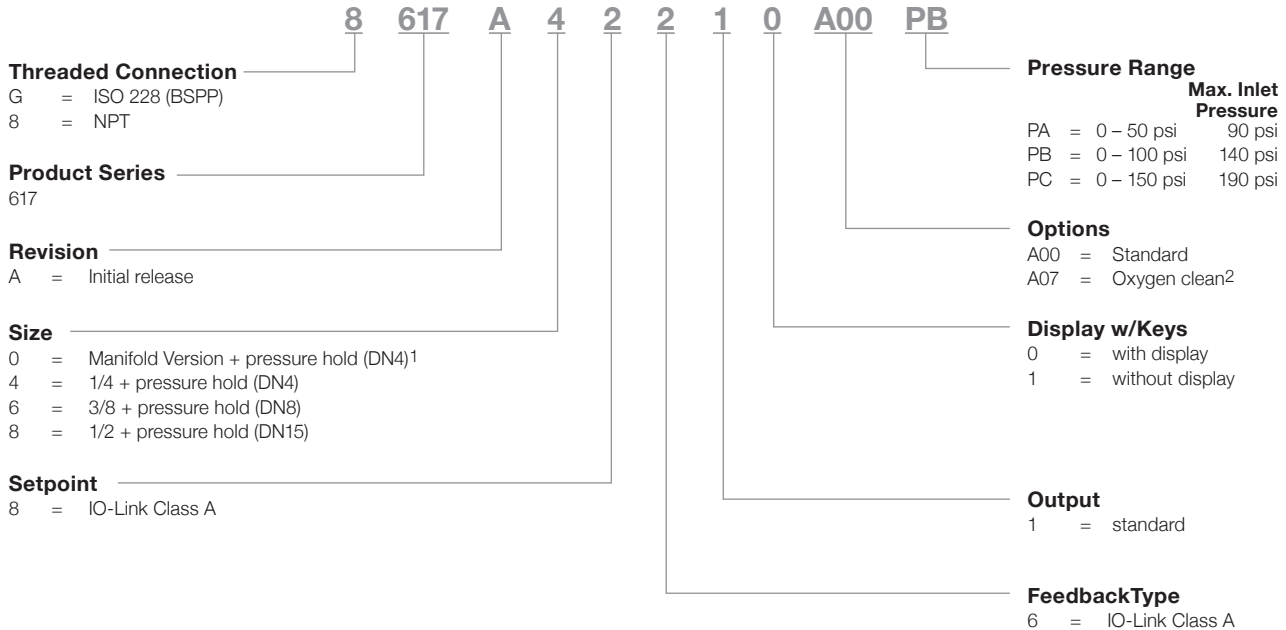

<sup>1</sup> See Accessories for individual subbases for this Manifold Version

<sup>2</sup> No Digital In possible

**Operating Elements**



- 1 Power supply, M12 plug
- 2 Pressure output
- 3 Protective ground - M4 connector
- 4 Exhaust
- 5 Pressure supply
- 6 LC display
- 7 Control keys
- 8 Mounting hole

**Manual Pressure Adjustment**

**(Manual Operation - Only for version with a display)**

If the supply voltage is cut off, after a reconnection of the supply voltage and by pressing the two arrow keys below the display at the same time, the pressure regulator will change to “Manual operation” mode. This operating mode is indicated in the display by the letters “HND”.

The letters “HND” in the display will disappear after the arrow keys are released. The output pressure is shown on the display, followed by the letters “HND” at the top right of the display.

Using the arrow keys, the output pressure can be changed (left arrow key or arrow pointing down => reduce the output pressure, right arrow key or arrow pointing up => increase the output pressure).

This operating mode can be exited by pressing both arrow keys at the same time or by briefly cutting off the supply voltage.

**Operating Modes**

**Shutoff:**

If the setpoint is set to less than 0.5%, the air will be released from the valve and the current supplied to the exhaust valve will be switched off after 10 seconds.

**Over temperature:**

If the internal control electronics reach a temperature above 100°C, the control function will be restricted in order to prevent any more overheating.

**Connector Pin Out / Cable Wiring**

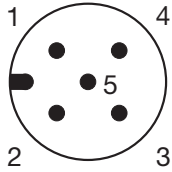

View from soldering side

Pin	Description
1	24 VDC voltage supply
2	not connected
3	Supply common
4	C/Q
5	not connected
Body	EMC screen

**M12 Class A & B Compatible Cables\* and Accessories**



M12 Straight 5 Pin Female Single Ended Cable - Unshielded
TC0505MIE000071P – 5 Meter
TC0510MIE000071P – 10 Meter



M12 Straight 5 Pin Female to Male Double Ended Cable - Unshielded
TC0505MIETA0571P – 5 Meter
TC0510MIETA0571P – 10 Meter



M12 90° 5 Pin Female Single Ended Cable - Unshielded
TD0505MIE000071P – 5 Meter
TD0510MIE000071P – 10 Meter



M12 90° 5 Pin Female to Male Double Ended Cable - Unshielded
TD0505MIETA0571P – 5 Meter
TD0510MIETA0571P – 10 Meter

Manifold (individual subbases that join together)	
Manifold for 617 DN4 with pressure supply/exhaust 3/8 NPT & output 1/4 NPT <sup>1</sup>	N50781800200000
Manifold for 617 DN4 with pressure supply/exhaust G3/8 & output G1/4 (BSPP) <sup>1</sup>	N50781800000000

<sup>1</sup> Manifold ships with required hardware and gaskets for connecting manifolds together.

\*Reference our G3 Fieldbus catalog for M12 4 pin cables if the selected IO-Link® Master does not accept 5 pin cables. Maximum IO-Link cable length is 20m.

## Analog Target Value - Output Pressure

### Setpoint Onset

The maximum adjustment range for the zero point is from 0% to +100%.

Maximum Output Pressure PMR (psi)	Maximum Input Pressure MAP (psi)
50	90
100	140
150	190

WARNING: Output pressures greater than the PMR (Pressure Maximum Range) will not be regulated by the valve, i.e. the maximum output pressure is limited to the PMR.

In order to prevent damage to the sensor, the supply pressure should always be less than the maximum input pressure (MAP) (see table).

### Setpoint span

The pressure range of the target value can be changed using the DaS software. To do this, in the section “Setpoint setting” switch to “Customer”. The adjustment range for the pressure is 10% to 200%.

## Pneumatic Connection

The air flow direction is from connection 1 to 2.



- 1 Pressure supply at connection 1
- 2 Pressure output at connection 2
- 3 Air released at connection 3

Inch screw connections (pipe threads) are to be used.

Each screw connection must be lined with a fitting plastic sealing ring.

Teflon sealing tape and hemp may not be used, because some of these materials may end up inside the valve.

A suitable silencer is to be used at port (3). Depending on the type of silencer used, the time required for the air to be released may be extended.

The cross-section of the pneumatic lines must be adjusted to the nominal diameter of the valve. The output line (2) should have a cross-section greater than or equal to the input line (1).

The supply pressure must always be less than the value specified in the table in section 3, but it must always be greater than the desired output pressure.

## Information on the Factory Settings

- Output pressure: 0 psi with a setpoint of 0
- Pressure range: 50 psi device = 50 psi  
100 psi device = 100 psi  
150 psi device = 150 psi
- Minimal hysteresis
- The control parameters, the zero point and the pressure range are factory-set.

## Set of Parameters: Factory Settings

Zero point: 0%

Pressure range: 100%

Setpoint ramp: none

Shut-off point: ON; with a target value of less than 0.5%, the air will be released from the valve

Control system: PID

## Technical Characteristics

### Fluid Characteristics

Fluids:	Air or neutral gas, filtered at 50 µm condensate-free, lubricated or unlubricated, class 5 according to ISO 8573-1:2010 [7:4:4]	
Minimum Required pressure:	At least 15 psi above the maximum outlet pressure	
Pressure range:	0 – 50 psi, 0 – 100 psi, 0 – 150 psi	
Fluid temperature:	0 °C to 60 °C (32 °F to 140 °F)	
Ambient temperature:	0 °C to 50 °C (32 °F to 122 °F)	
Setpoint:	Digital setpoint in steps of 0.0145 psi 0 – 10345 = 0 – 150 psi (0 – 1000 = 0 – 10 bar)	
Hysteresis:	1.5% of span	
Linearity:	1.5% of span	
Repeatability:	1.5% of span	
Minimum setpoint:	0.5% of span with shut-off function	
Minimum outlet pressure:	1% of span	
Failsafe behavior:	Pressure on hold on loss of power, without control	

### Construction

Body:	Aluminum
Internal parts:	POM (polyacetal)
Seals:	NBR (nitrile)

### Key Values

IO-LINK	
Protocol Version	Specification V1.1
Baudrate	COM3 (230.4 kBaud)
Minimum cycle time	0.5 ms
Process data	2 Byte IN, 2 Byte OUT
Port type	Class A

Electrical Characteristics						
Nominal Diameter DN (mm)	Voltage *	Max. Power (W)	Max. Current (mA)	Insulation Class	Degree of Protection	Electrical Connection
4, 8, 15	24 VDC = ± 10%	3.8 W (< 1 W at pressure)	160	H	IP65	5-pin M12 connector (not supplied)

\* Max. ripple: 10%

Specifications			
Ø Ports NPT or BSPP	Ø Orifice DN (mm)	Flow	
		C <sub>v</sub> Flow Factor (K <sub>v</sub> Nm <sup>3</sup> /h)	at 6 Bar (l/min - ANR)
1/4	4	0.50 (0.43)	470
3/8	8	1.39 (1.20)	1300
1/2	15	5.57 (4.80)	5200

## Care and Maintenance

### Installation and Operating Instructions

1. Before putting the pressure regulator into operation, carry out a careful inspection of the electrical connections and the supply voltage (24 VDC  $\pm$ 10%). An overvoltage can damage the electronic systems.  
Recommended fuse protection T 0.5 A
2. The electrical connection is made using a circular plug connector M12x1. The connector used must comply with the requirements of German standard DIN 60079-15.

#### **Safety notice:**

#### **The plug must not be pulled out when a voltage is running through it!**

When the connector plug is removed from its socket, in order to maintain the IP protection class, the protective cap supplied with the device must be fitted.

3. For the electrical connection of the valve, shielded or unshielded cables may be used. The connection, plug and switch cabinet must comply with EMC requirements. The valve body must be electrically grounded (protective earthing, machine grounding). Do not install control cables parallel to power cables or control cables of servomotors etc.
4. The cable cross-section area of the supply voltage cable should be at least 0.25 mm<sup>2</sup>.  
If long supply cables are used, it may be appropriate for them to have an even larger cable cross-section area.
5. Make sure that the valve is subjected to pressure as soon as a target value signal is sent to the valve (if a target value setting is sent to the valve without the valve being under pressure, this will result in unacceptable excessive heating of the valve).
6. The device is calibrated with factory settings.
7. The device must be sent to the factory if repairs are needed.

### Safety Instructions

These products must only be used in industrial compressed air systems. These products are to be used in locations where the pressures and temperatures listed under "Specifications" are not exceeded. Please take note of the relevant page in the instruction manual.

Before using these products with fluids other than those specified in the manual, or in non-industrial applications, life-support systems, or in other systems which are not specified in the published instruction manuals, please contact ASCO Numatics directly.

The components used in fluid power systems can fail in various ways due to misuse, wear or system malfunctions.

**System designers are warned to make it a priority to take into account the possible types of faults of all component parts used in fluid power systems, and to provide adequate safeguards to prevent injuries to staff or damage to equipment in the event of such faults.**

System designers must provide safety instructions for the end users in the operating manual if protection against faults cannot be sufficiently guaranteed.

System designers and end users are strongly advised to comply with the safety instructions provided with these products.

Dimensions: mm

**DN 4**

**Inline version**

Weight: 0.49kg (1.08lbs)

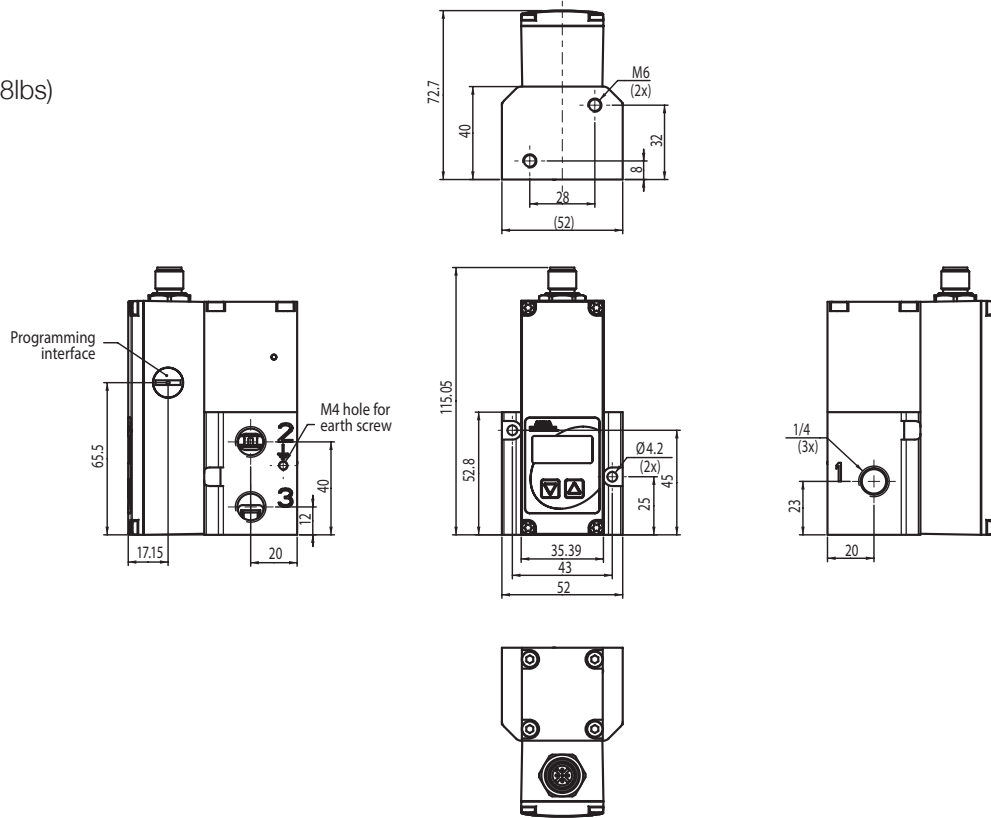

**DN 4**

**Subbase version**

Weight: 0.49kg (1.08lbs)

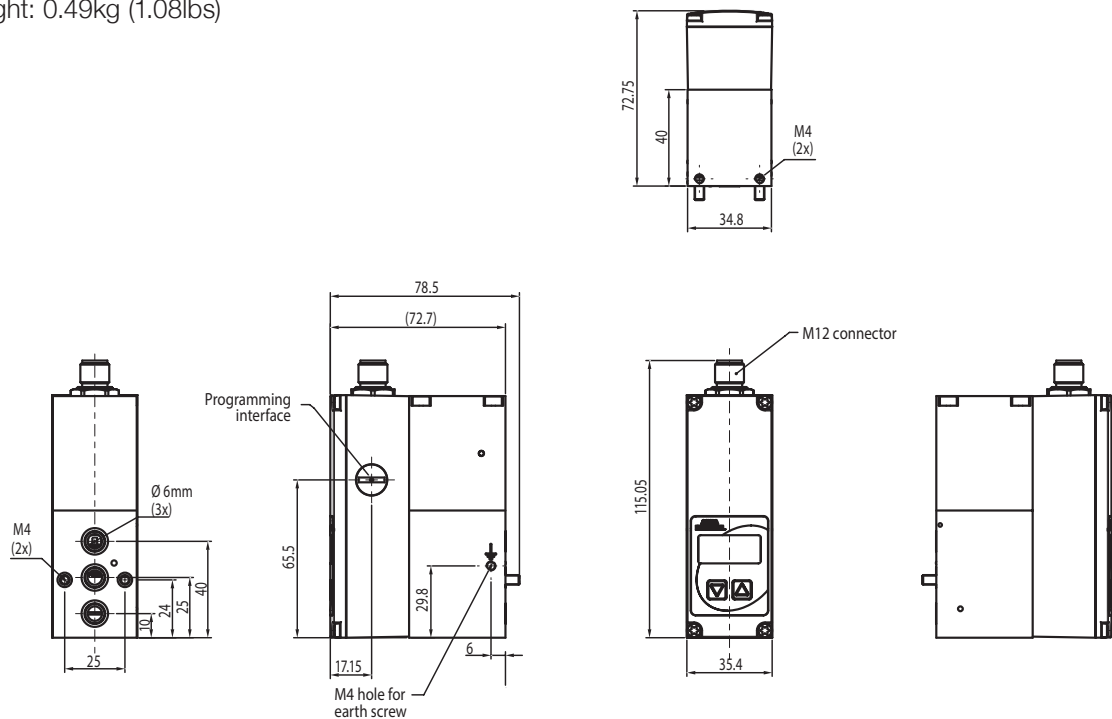

**Dimensions: mm**

**DN 4**

**Joinable subbase**

Weight: 0.3kg (0.66lbs)

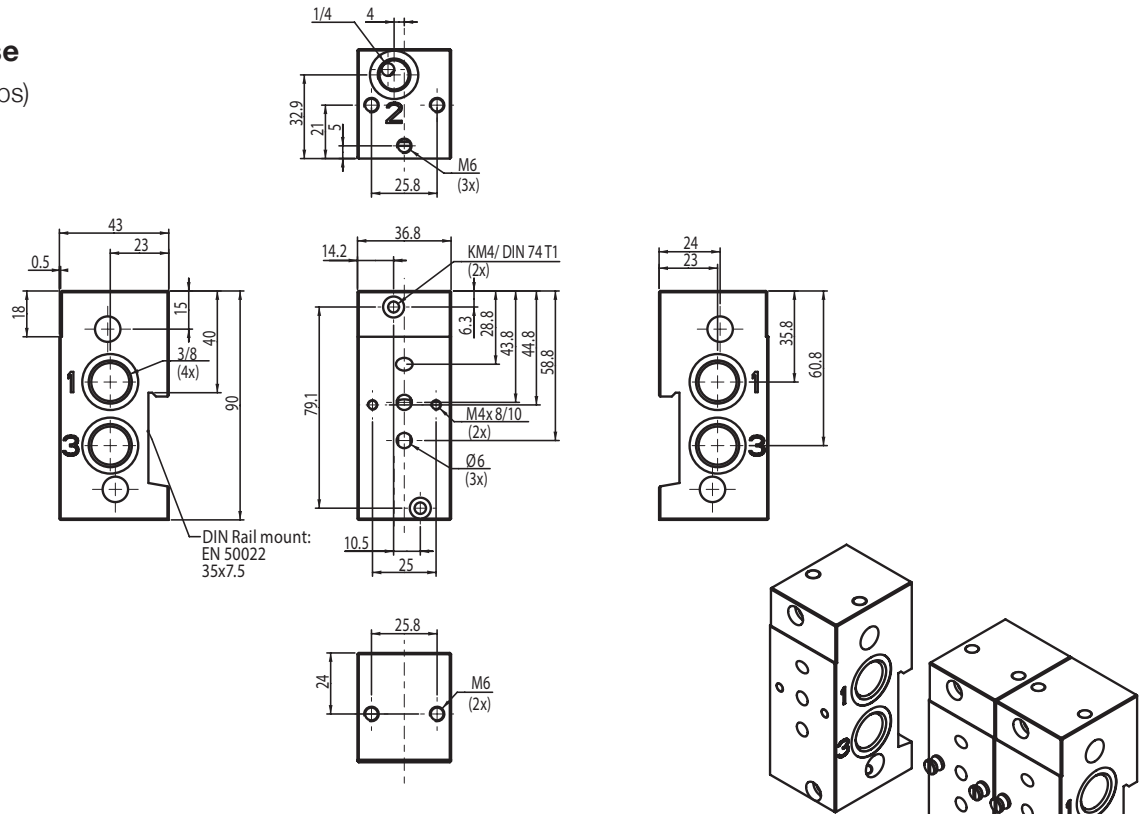

**DN 8**

Weight: 0.93kg (2.05lbs)

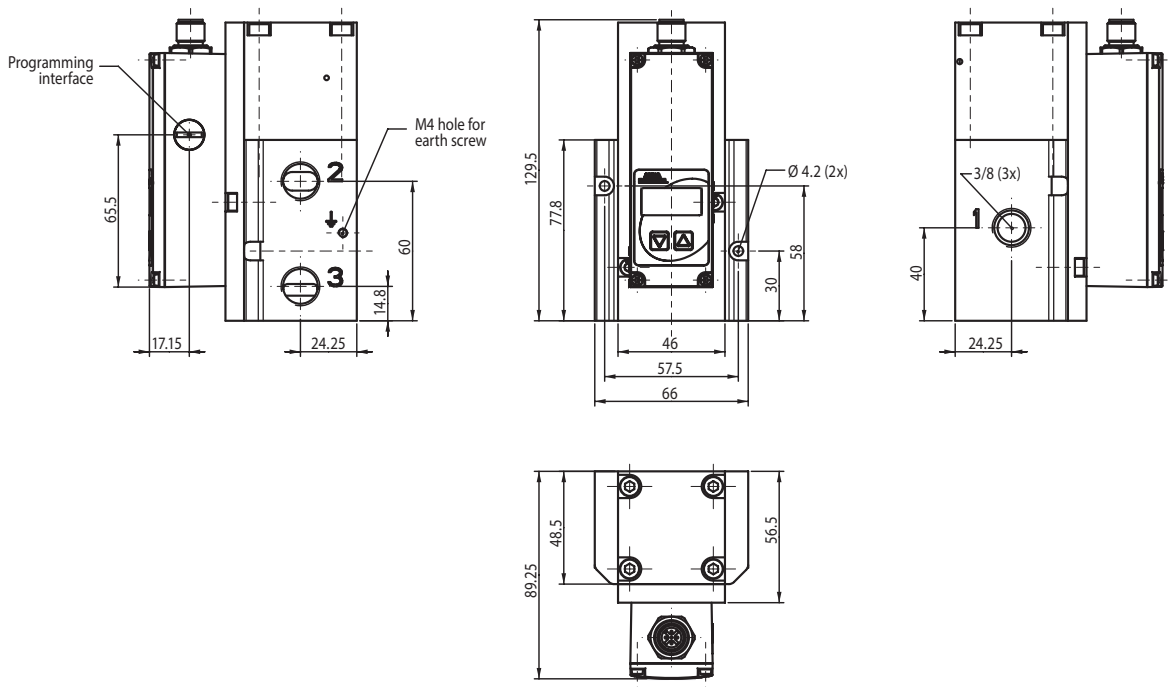

**Dimensions: mm**

**DN 15**

Weight: 1.33kg (2.93lbs)

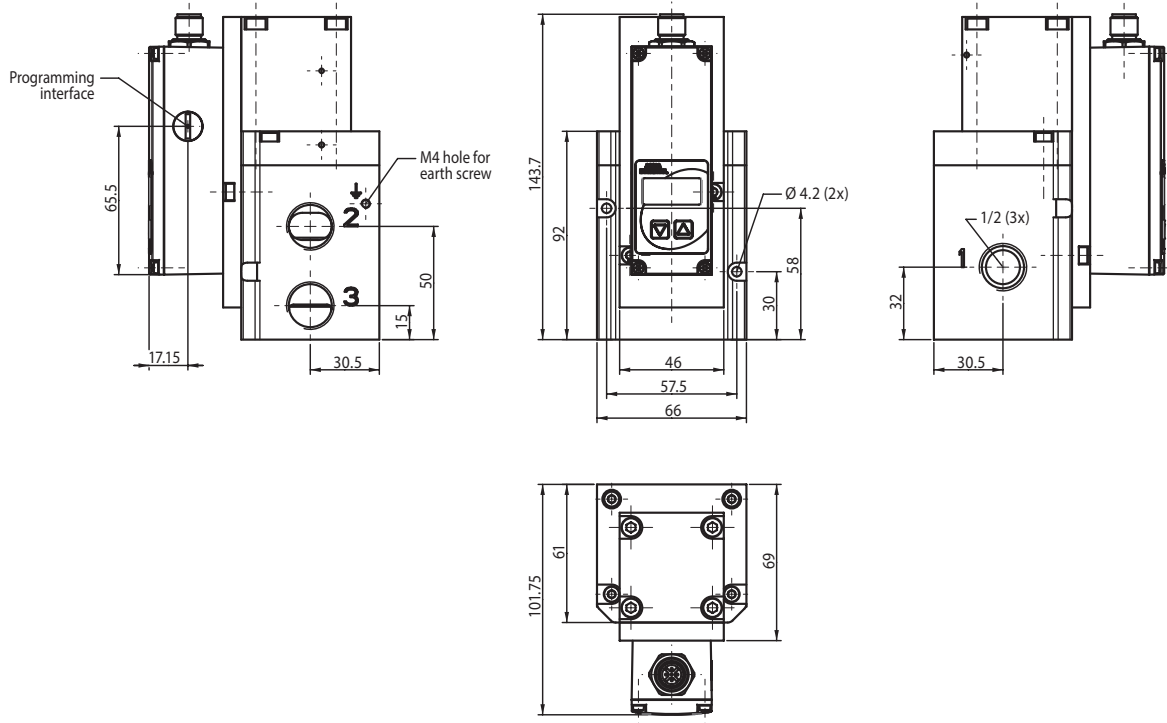



## Global Contacts

Australia	(61) 2-9-451-7077	France	(33) 2-37-24-42-24	Netherlands	(31) 33-277-7911
Brazil	(55) 11-4208-1700	Germany	(49) 7237-9960	Singapore	(65) 6556-1100
Canada	(1) 519-758-2700	India	(91) 44-39197300	South Korea	(82) 2-3483-1570
China	(86) 21-3395-0000	Italy	(39) 02-356931	Spain	(34) 942-87-6100
Czech Republic	(420) 235-090-061	Japan	(81) 798-65-6361	United Kingdom	(44) 1695-713600
Dubai - UAE	(971) 4-811-8200	Mexico	(52) 55-5809-5640		