

STIRNRADGETRIEBE-MOTOREN

spur geared motors



PERFEKTES ZUSAMMENSPIEL - HOHE FLEXIBILITÄT

Perfect interaction - great flexibility

Durch zahlreiche Anpassungsmöglichkeiten und viele Übersetzungen sind sie für den Einsatz in den verschiedensten Anwendungen geeignet – im Gerätebau ebenso wie in harten industriellen Umgebungen. Robuste Sinterbronzelager, gehärtete Stahlräder und eine hochwertige Lebensdauerschmierung machen sie außergewöhnlich langlebig. Und wenn es auf die Laufruhe ankommt, sind natürlich geräuscharme Ausführungen möglich.

Their many customisation options and gear ratios make them suitable for use in a wide range of applications, from equipment manufacturing to heavy-duty industrial environments. The durable sintered bronze bearings, hardened steel gears and premium lifetime lubrication mean they offer an outstandingly long service life. And if smooth running is needed, low-noise variants are of course available.

VORTEILE

benefits

- Hoher Wirkungsgrad auch bei hohen Übersetzungen
high efficiency even at high gear ratios
- Ausgezeichnetes Preis-/ Leistungsverhältnis
excellent cost-performance ratio

EIGENSCHAFTEN

characteristics

- Geringes Getriebeispiel
low backlash
- wartungsfrei
maintenance free

OPTIONEN

options

- Low-Noise-Ausführungen
low-noise versions
- Sonderwellen
customised shafts
- Sonderschmierungen
special lubrication

Allgemeine Angaben <i>general datas</i>	
Gehäuse <i>housing</i>	Aluminium-Druckguss <i>aluminium die-cast</i>
Zahnräder <i>gear wheels</i>	Gehärteter Stahl mit hoher Belastbarkeit <i>hardened heavy duty steel</i>
Wellenlagerung <i>shaft bearings</i>	selbstschmierende Sinterlager <i>self-lubricating sinter bearings</i>
Schmierung <i>lubrication</i>	Lebensdauerfettung <i>lifetime lubrication</i>
Getriebeispiel <i>backlash</i>	ca. 0,8° <i>approx. 0.8</i>
Schutzart <i>protection class</i>	IP40 (optional IP55)
Einbaulagen <i>assembly position</i>	beliebig <i>any</i>
RoHS, WEEE, REACH	✓
Grenzdaten <i>limit datas</i>	
Umgebungstemperaturen <i>ambient temperatures</i>	-25 °C - +50 °C
Max. Radial-/Axiallast <i>max. radial/axial load</i>	
Type G	120 N / 20 N
Type V	150 N / 30 N
Type W	180 N / 40 N

ABMESSUNGEN MOTOREN MIT STIRNRADGETRIEBE G
dimensions motors with spur gear G

Getriebemotor <i>geared motor</i>	Litzenausführung <i>lead wire type</i>		Klemmkastenausführung <i>terminal box type</i>	
	Länge in mm <i>length in mm</i>	Gewicht in kg <i>weight in kg</i>	Länge in mm <i>length in mm</i>	Gewicht in kg <i>weight in kg</i>
RO ... 34 / 36	103	0,90	147	1,00
RO ... 44 / 46	115	1,10	159	1,20
RO ... 64 / 66	133	1,35	177	1,45
RO ... 84 / 86	158	1,75	202	1,85

ABMESSUNGEN MOTOREN MIT STIRNRADGETRIEBE V/W
dimensions motors with spur gear V/W

Getriebemotor <i>geared motor</i>	Litzenausführung <i>lead wire type</i>		Klemmkastenausführung <i>terminal box type</i>	
	Länge in mm <i>length in mm</i>	Gewicht in kg <i>weight in kg</i>	Länge in mm <i>length in mm</i>	Gewicht in kg <i>weight in kg</i>
RO ... 34 / 36	103	1,00	147	1,10
RO ... 44 / 46	115	1,20	159	1,30
RO ... 64 / 66	133	1,45	177	1,55
RO ... 84 / 86	158	1,85	202	1,95

MASSBILD MOTOREN MIT STIRNRADGETRIEBE G
scale drawing motors with spur gear G

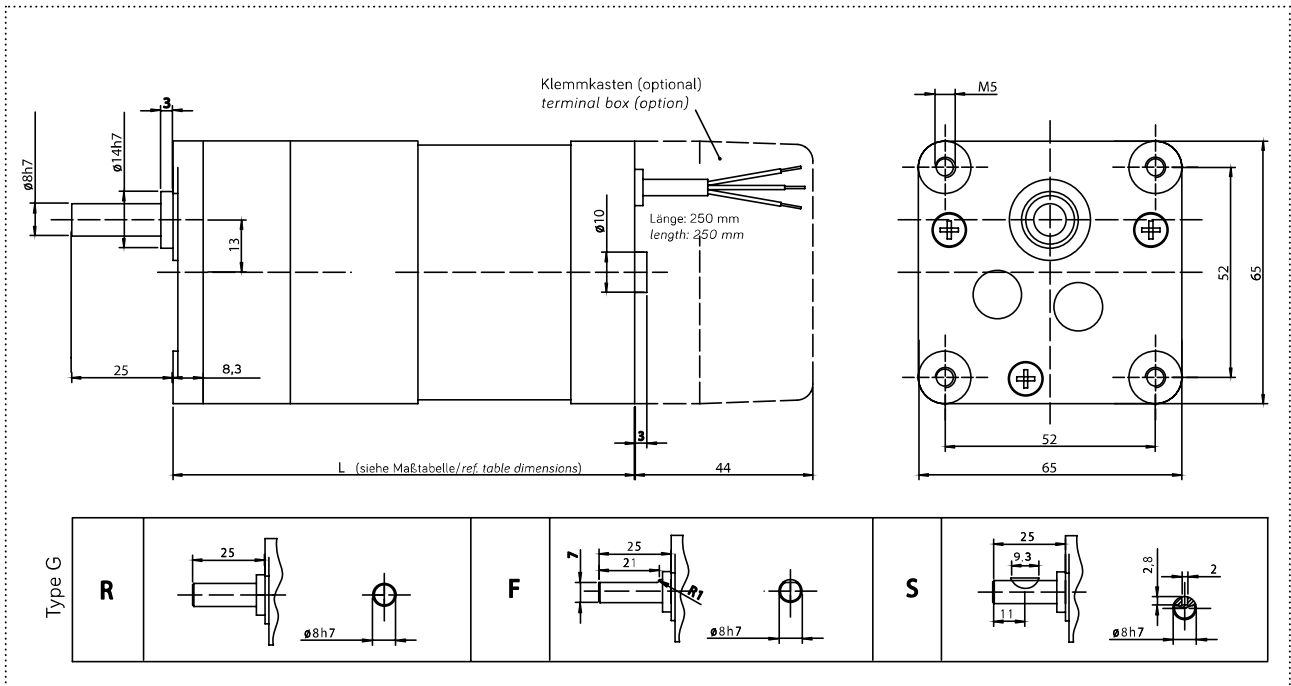

MASSBILD MOTOREN MIT STIRNRADGETRIEBE V/W
dimensions motors with spur gear V/W

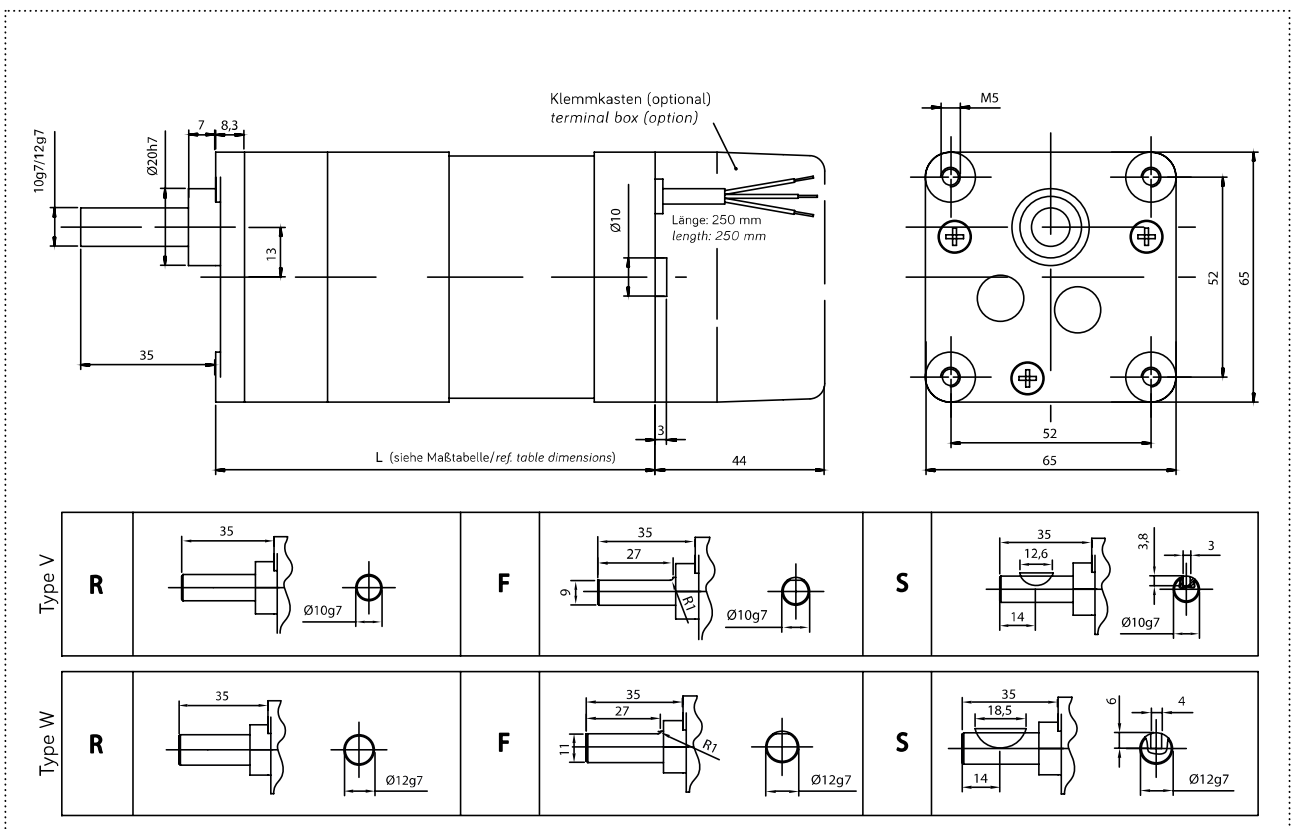

DATEN STIRNRADGETRIEBE-MOTOREN ROBASE (6-POLIG, 1~230 V, 50 HZ)
datas spur geared motors ROBASE (6 poles, 1~230 V, 50 Hz)

Übersetzung ratio	zulässiges Drehmoment (Spitze) permitted torque (peak)			Drehzahl speed	Drehmoment der Motortypen torque of motor types			
	Type G Nm	Type V Nm	Type W Nm		36 Nm	46 Nm	66 Nm	86 Nm
i				1/min				
2-stufig $\eta = 81\%$ 2 stages $\eta = 81\%$								
5	6 (10)	-	-	200	0,30	0,45	0,61	0,85
10	6 (10)	-	8 (13)	100	0,61	0,89	1,22	1,70
13,3	6 (10)	-	-	75	0,81	1,19	1,62	2,26
16,6	6 (10)	-	-	60	1,01	1,48	2,02	2,82
20	6 (10)	-	-	50	1,22	1,78	2,43	3,40
3-stufig $\eta = 73\%$ 3 stages $\eta = 73\%$								
25	6 (10)	-	-	40	1,37	2,01	2,74	3,83
33,3	6 (10)	8 (13)	-	30	1,82	2,67	3,65	5,10
50	6 (10)	-	8 (13)	20	2,74	4,02	5,48	7,67
60	6 (10)	-	8 (13)	16,6	3,29	4,82	6,57	9,20
66,6	6 (10)	-	-	15,0	3,65	5,35	7,29	10,21
4-stufig $\eta = 66\%$ 4 stages $\eta = 66\%$								
75	6 (10)	-	8 (13)	13,3	3,71	5,45	7,43	10,40
100	6 (10)	-	8 (13)	10	4,95	7,26	9,90	13,86
125	6 (10)	8 (13)	8 (13)	8	6,19	9,08	12,38	-
150	6 (10)	-	-	6,6	7,43	10,89	14,85	-
200	6 (10)	-	8 (13)	5	9,90	14,52	-	-
250	6 (10)	8 (13)	8 (13)	4	12,38	-	-	-
5-stufig $\eta = 59\%$ 5 stages $\eta = 59\%$								
500	6 (10)	8 (13)	-	2	22,13	-	-	-
1000	6 (10)	8 (13)	-	1	44,25	-	-	-
1333,3	6 (10)	-	-	0,75	59,00	-	-	-

Bei Überschreiten des zulässigen Drehmoments kann das Getriebe beschädigt werden. Three-phase variants offer 10 to 30% more torque.
 Exceeding the maximum permissible torque may lead to gear damage. Three-phase variants offer 10 to 30% more torque.

DATEN STIRNRADGETRIEBE-MOTOREN ROBASE (4-POLIG, 1~230 V, 50 HZ)
datas spur geared motors ROBASE (4 poles, 1~230 V, 50 Hz)

Übersetzung ratio	zulässiges Drehmoment (Spitze) permitted torque (peak)			Drehzahl speed	Drehmoment der Motortypen torque of motor types			
	Type G Nm	Type V Nm	Type W Nm		34 Nm	44 Nm	64 Nm	84 Nm
2-stufig $\eta = 81\%$ 2 stages $\eta = 81\%$								
5	6 (10)	-	-	300	0,24	0,36	0,49	0,73
10	6 (10)	-	8 (13)	150	0,49	0,73	0,97	1,46
13,3	6 (10)	-	-	112,5	0,65	0,97	1,29	1,94
16,6	6 (10)	-	-	90	0,81	1,21	1,61	2,42
20	6 (10)	-	-	75	0,97	1,46	1,94	2,92
3-stufig $\eta = 73\%$ 3 stages $\eta = 73\%$								
25	6 (10)	-	-	60	1,10	1,64	2,19	3,29
33,3	6 (10)	8 (13)	-	45	1,46	2,19	2,92	4,38
50	6 (10)	-	8 (13)	30	2,19	3,29	4,38	6,57
60	6 (10)	-	8 (13)	25	2,63	3,94	5,26	7,88
66,6	6 (10)	-	-	22,5	2,92	4,38	5,83	8,75
4-stufig $\eta = 66\%$ 4 stages $\eta = 66\%$								
75	6 (10)	-	8 (13)	20	2,97	4,46	5,94	8,91
100	6 (10)	-	8 (13)	15	3,96	5,94	7,92	11,88
125	6 (10)	8 (13)	8 (13)	12	4,95	7,43	9,90	14,85
150	6 (10)	-	-	10	5,94	8,91	11,88	-
200	6 (10)	-	8 (13)	7,5	7,92	11,88	15,84	-
250	6 (10)	8 (13)	8 (13)	6	9,90	14,85	-	-
5-stufig $\eta = 59\%$ 5 stages $\eta = 59\%$								
500	6 (10)	8 (13)	-	3	17,70	-	-	-
1000	6 (10)	8 (13)	-	1,5	35,40	-	-	-
1333,3	6 (10)	-	-	1,125	47,20	-	-	-

Bei Überschreiten des zulässigen Drehmoments kann das Getriebe beschädigt werden. Three-phase variants offer 10 to 30% more torque.
 Exceeding the maximum permissible torque may lead to gear damage. Three-phase variants offer 10 to 30 % more torque.

DATEN STIRNRADGETRIEBE-MOTOREN ROSYNC (4-POLIG, 50 HZ)
datas spur geared motors ROSYNC (4 poles, 50 Hz)

Übersetzung ratio	zulässiges Drehmoment (Spitze) permitted torque (peak)			Drehzahl speed	Drehmoment 1~ Motortypen torque 1~ motor types		Drehmoment 3~ Motortypen torque 3~ motor types	
	Type G Nm	Type V Nm	Type W Nm		44 Nm	84 Nm	44 Nm	84 Nm
i				1/min				
2-stufig $\eta = 81\%$ 2 stages $\eta = 81\%$								
5	6 (10)	-	-	300	0,53	0,93	1,30	-
10	6 (10)	-	8 (13)	150	1,05	1,86	2,59	-
13,3	6 (10)	-	-	112,5	1,40	2,48	3,45	-
16,6	6 (10)	-	-	90	1,75	3,09	4,30	-
20	6 (10)	-	-	75	2,11	3,73	5,18	-
3-stufig $\eta = 73\%$ 3 stages $\eta = 73\%$								
25	6 (10)	-	-	60	2,37	4,20	5,84	-
33,3	6 (10)	8 (13)	-	45	3,16	5,59	7,78	-
50	6 (10)	-	8 (13)	30	4,75	8,40	11,68	-
60	6 (10)	-	8 (13)	25	5,69	10,07	14,02	-
66,6	6 (10)	-	-	22,5	6,32	11,18	15,56	-
4-stufig $\eta = 66\%$ 4 stages $\eta = 66\%$								
75	6 (10)	-	8 (13)	20	6,44	-	-	-
100	6 (10)	-	8 (13)	15	8,58	-	-	-
125	6 (10)	8 (13)	8 (13)	12	10,73	-	-	-
150	6 (10)	-	-	10	12,87	-	-	-
200	6 (10)	-	8 (13)	7,5	17,16	-	-	-
250	6 (10)	8 (13)	8 (13)	6	-	-	-	-
5-stufig $\eta = 59\%$ 5 stages $\eta = 59\%$								
500	6 (10)	8 (13)	-	3	-	-	-	-
1000	6 (10)	8 (13)	-	1,5	-	-	-	-
1333,3	6 (10)	-	-	1,125	-	-	-	-

Bei Überschreiten des zulässigen Drehmoments kann das Getriebe beschädigt werden.
Exceeding the maximum permissible torque may lead to gear damage.