

Original attachment



FLUXTRONIC
® Normal Mode

Page 21 - 38



Achtung

Lesen Sie die Betriebsanleitung für Durchflussmesser und die produkt-spezifischen Anhänge, bevor Sie das Gerät in Betrieb nehmen!



Attention

Read the main operating instructions for flow meters and the included product-specific attachments before operating the device!



Attention

Lisez la notice d'instructions générale pour les compteurs de débit ainsi que les annexes spécifiques aux produits avant de mettre l'équipement en service !

Content

1	Safety	22
1.1	Intended Use.....	22
1.2	Foreseeable misuse.....	22
1.3	Safety instructions.....	22
1.4	Safety information when using the FLUXTRONIC® in hazardous areas	23
1.5	Using pulse redirection in hazardous areas.....	23
2	FLUXTRONIC®	25
2.1	Operating the FLUXTRONIC®	25
2.2	The operating concept.....	26
3	General information	26
3.1	Menu in normal mode	27
4	Technical data	34
5	Change of FLUXTRONIC® or battery	37
6	Commissioning	37
7	In operation	38
8	Repair	38
9	Disposal	38

1 Safety

1.1 Intended Use

Flow meters allow for convenient measuring of liquids.
Do not expose the flow meters to the weather.
Observe the minimum and maximum operating temperatures.
Observe the maximum operating pressure.
Only use clean liquids.

1.2 Foreseeable misuse



Caution!

- > The device may only be used for the purposes given by the manufacturer. Unauthorized changing and the use of spare parts and accessories that are not sold or recommended by the manufacturer may cause damages or physical injuries.
- > Children and other uninstructed persons should be supervised to ensure that they do not play with the device.

1.3 Safety instructions

All safety instructions must be observed and followed.
Failure to follow the safety instructions may lead to serious injury or death or cause environmental and/or property damage.
Adherence to the safety instructions contained in these operating instructions will help you to avoid risks and to ensure that the product is used to its full potential.
Safety instructions on the activities are listed at the start of the respective chapter.
Special safety instructions on individual action steps are given under the respective action step.



Attention!

- > Make sure that the operator has read and understood the operating instructions.



Danger of poisoning from harmful substances / vapours

- > Take off spilled harmful substances.
- > Never eat or drink when filling harmful liquids.



Attention - danger from splashing liquids!

- > The maximum operating pressure and operating temperature must not be exceeded.
- > High operating pressure may result in the containers or the hoses bursting or becoming loose. Make sure that excessive pressure does not result when filling a container.
- > Fill carefully and at an appropriate speed to avoid leakage of the liquid.







Caution!

- > Immediately inform the responsible supervisor about defects on the device.

Caution - risk of injury!

- > Follow internal instructions.
- > Wear protective clothing (face and breathing protection, protective gloves, etc.).

Attention!

- > If the material of the flow meter is not resistant to the liquid to be transferred, it must not be used.
- > Observe the chemical resistance and internal instructions.



Note

- > Always replace defective parts.
- > Only use genuine spare parts.
- > When returning the pump for repair, it must be accompanied by the decontamination certificate (download at www.flux-pumps.com).



1.4 Safety information when using the FLUXTRONIC® in hazardous areas

- > Please refer to the certificates of acceptance and operating instructions of all units used in hazardous areas.



- > Avoid electrostatic charges when installing and operating this equipment.
- > Only clean with a damp cloth.
- > Only clean outside of the hazardous area.



- > Only change the battery outside of the hazardous area.
- > Only operate with a battery in hazardous areas.
- > Remove the electronic display unit when changing the battery.



Information when transporting in explosion-protected areas

- > Avoid electrostatic charges when transporting.
- > Note internal operating instructions.



- > Observe the Technical Guidelines for "Combustible Liquids" and the German Institution for Statutory Accident Insurance and Prevention in the Chemical Industry (BG Chemie) Explosion Protection Guidelines during installation and operation.



1.5 Using pulse redirection in hazardous areas

The use of the FLUXTRONIC® in hazardous areas means that it is necessary to select a signal interface permitted in areas at risk from explosion. The NAMUR* interface has proved itself in this respect (* NAMUR = **N**ormen **A**usschuss **M**ess- und **R**egeltechnik). An isolating amplifier with a NAMUR input, capable of switching up to a minimum of 150 Hz, is needed to use this signal.



- > If you are using your own switching amplifier, it is imperative that you note the certificates of conformity of the electronic analysis unit and the switching amplifier you are using.



- > The switching amplifier and the external units connected to it should only be installed, operated and serviced by trained and qualified personnel.



- > Power should only be switched on once the units have been installed and live parts cannot be touched.



Danger to life from touching live parts!

- > Always keep switching cabinets locked.
- > Do not undertake any work on live parts.
- > Change loose connections and any damaged, scorched or burnt through cables immediately. Only undertake any work when the main switch has been disconnected and shut off.
- > Ensure that no cables are trapped or squashed. Ensure that the cables are laid in such a way that they do not lead to any trip hazards or can be damaged.
- > All work may only be undertaken by skilled personnel who have been instructed and trained on the system.
- > Only authorised personnel with a key or tool are allowed to access the switching cabinets.
- > We recommend that the power supply is fitted with an FI safety switch in damp areas.
- > Power should only be switched on once the equipment has been installed and live parts cannot be touched.



If the switching amplifier and FLUXTRONIC® are located in a hazardous area (zone 1) only approved switching amplifiers (category 2) should be used.



If the switching amplifier is located outside of the hazardous area and the FLUXTRONIC® in the hazardous area (zone 1) only approved switching amplifiers with a control circuit (category 2) should be used.

2 FLUXTRONIC®

The electronic analysis unit FLUXTRONIC® displays the volume of liquid that has flown through a flow meter.

The nutating disc meter generates pulses by volume (e.g. 0.05 l/pulse). The pulses are registered by the electronic analysis unit and converted into the actual volume via a calibration constant.

Number of pulses x calibration constant = volume.

The electronic unit can be used in two different operating modes:

Operating mode 1: Normal mode

In normal mode the volume that flows through a flow meter is displayed.

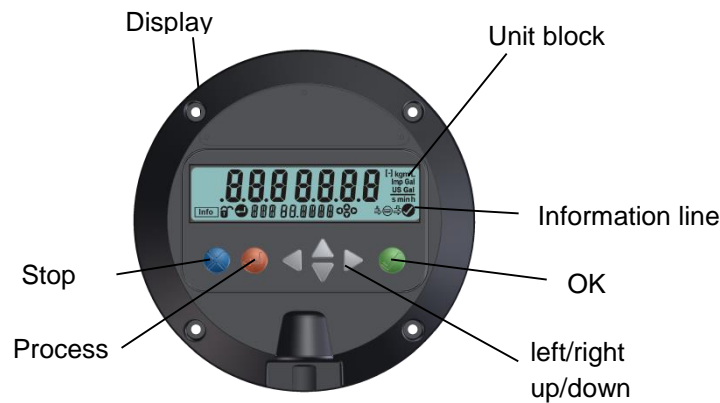

Keep organic solvents away from the keyboard and LCD display.

2.1 Operating the FLUXTRONIC®

The FLUXTRONIC® contains five menu items.

The user can switch between the items at any time using the Up and Down keys.

The key figure for each respective item is displayed.

1. BC RUN: The volume to be filled is displayed
2. TOT: The total volume is displayed
3. FLO: The flow rate is displayed
4. CAL 0: The current calibration constant is displayed
5. SET: General settings

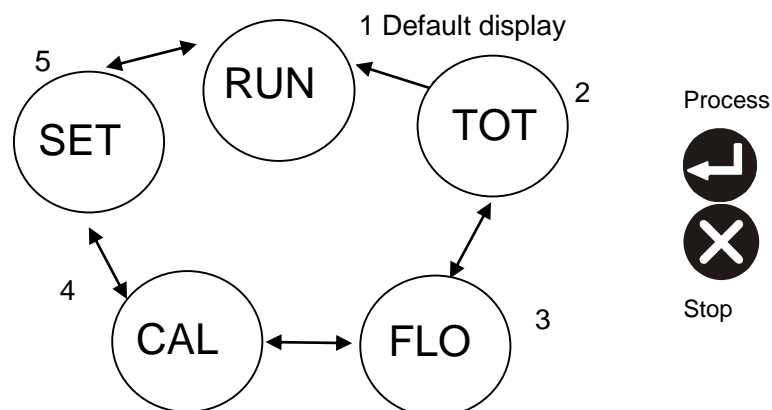

2.2 The operating concept

All of the settings are inputted using the following operating concept.

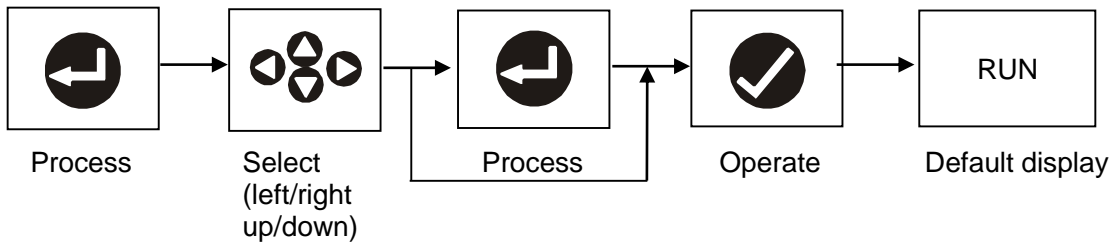

The current and possible settings can be quickly seen by feedback in the info line and by the flashing symbols.

3 General information



The **Stop key can be pressed at any time** and is not shown for this reason. Pressing the key once moves you back one step.



If this symbol appears on the display, the **PIN must firstly be entered** before processing.

For setting, refer to the [SET] group in chapter 5 -> Security Level (5.1) and PIN No. (5.2)



Operation of the unit is permitted when this symbol is shown on the display.



This symbol flashes if **pulses are detected at the input**.



The **display is switched off** if no pulse is measured or if no key is pressed for 5 minutes. The display switches on again as soon as a pulse is detected or a key pressed.

The unit cannot be operated when pulses can still be measured and the **SET range is not displayed**. The unit can be operated one second after the last pulse was measured and the SET range can be accessed again.

If no entries are made during operating in a group for one minute, the unit automatically switches over to [RUN].

Forgotten your PIN?

Reset security level [LOC] to 0 and Reset PIN number to "000"

All other entries are retained.

1. Remove battery from the battery compartment.
2. Press the Stop key before inserting the battery and hold it down while it is being inserted.

When the battery capacity is almost empty, the information line shows "**LOW BATT**" alternatively with the current line. When this is the case, the electronic unit can run normally for up to 2 weeks.

When the battery capacity is so low that processing can no longer be reliably guaranteed, the display only shows "LOW BATT" and the functions are no longer executed.

Software version

The version currently used is shown at [SET]->[INFO]->[01].

3.1 Menu in normal mode

Menu	Chapter	Designation	Action	Figures
1 [RUN]	Default display in normal mode			7-digit
	1.1	Volume display	delete immediately	
	1.2 [DEL]	Volume display	delete	
	1.3 [DEC]	Decimal place of display	change	0, 1, 2, 3
2 [TOT]	Total volume display and settings			7-digit
	2.1 [DEL]	Display of total volume	delete	
	2.2 [DEC]	Decimal place of display	change	0, 1, 2, 3
3 [FLO]	Flowrate display and settings			7-digit
	3.1 [UNIT]	Time unit of flow rate display	change	s, min, h
	3.2 [DEC]	Decimal place of display	change	0, 1, 2, 3
	3.3 [GATE]	Gate time for determining flow rate	change	0.0 s [OFF] to 25.0 s
4 [CAL]	Calibration display and settings			
	4.1 [CAL]	Memory location for calibration constants	select	0 ... 9
	4.2 [SET]	Calibration constant	change	7-digit
	4.3 [UNIT]	Unit of volume	change	[-], kg, g, m ³ , ml, L, Imp GAL, US GAL
	4.4 [DEC]	Decimal place	change	0, 1, 2
5 [SET]	Display and settings of different operating parameters			
	5.1 [LOC]	Security level	change	0, 1, 2, 3, 4
	5.2 [PIN]	PIN no.	change	000 ... 999
	5.3 [↻]	Pulse redirection	change	On <-> Off
	5.4 [DEF]	Default values	reset	YES <-> NO
	5.5 [INFO]	Information	display	01, 02, ...

1. RUN

Default display

Display range: 9999.999 to 9999999

The point is moved when the respective display range is exceeded until the maximum display is reached. The counter then starts counting again at 0.

1.1 Immediately delete volume display



With LOC 4 (setting in [SET]) it is not possible to delete the volume display immediately. For processing, first enter the PIN.

1.2 Delete volume display [DEL]

1.3 Change decimal place [DEC] 0 to 3.

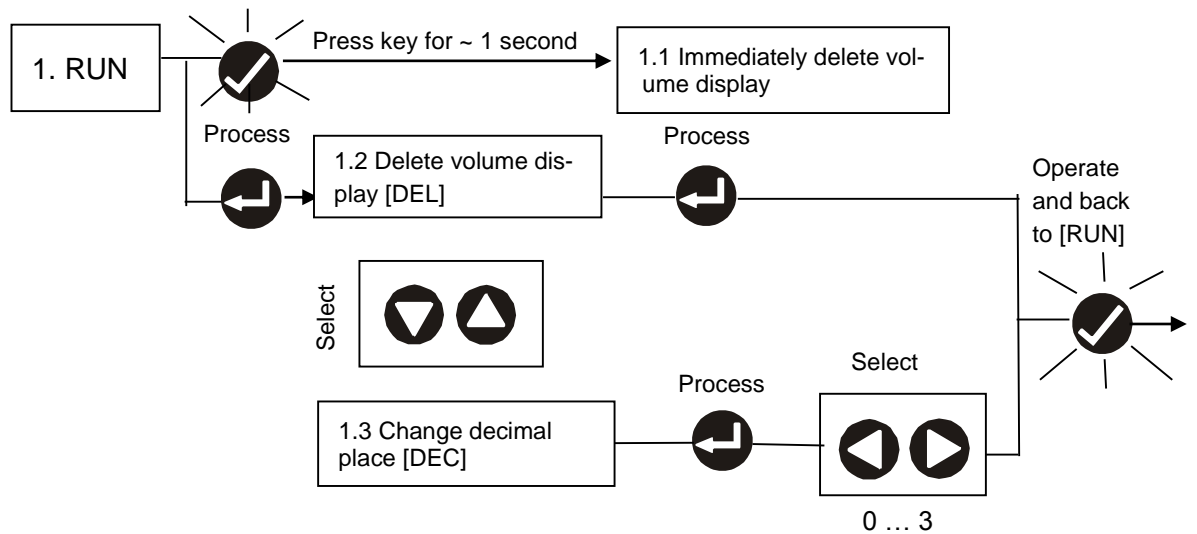

2. TOT

Display of total volume

Display range: 9999.999 to 9999999

The point is moved when the respective display range is exceeded until the maximum display is reached. The counter then starts counting again at 0.

2.1 Delete total volume [DEL]

2.2 Change decimal place [DEC] 0 to 3

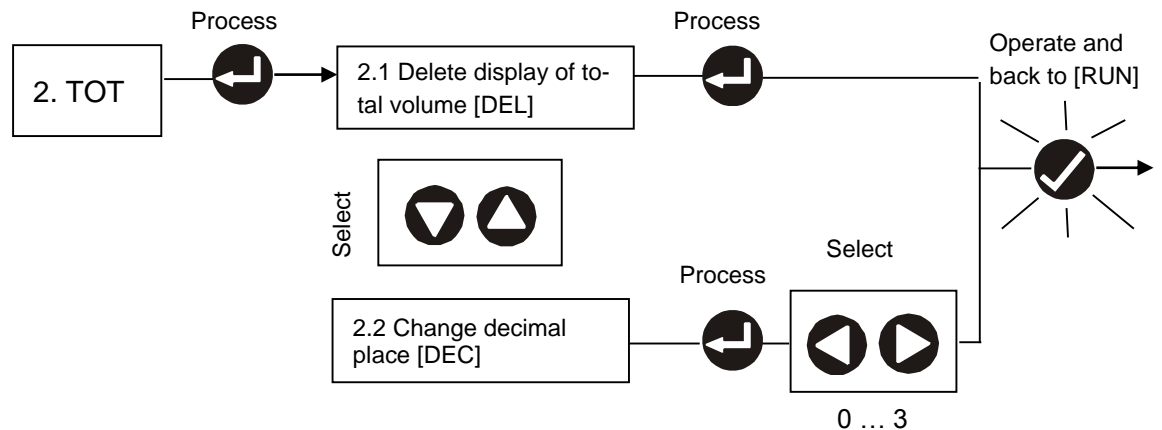

3. FLO

Display of flow rate

Display range: 9999.999 to 9999999.

The point is moved when the respective display range is exceeded until the maximum display is reached.

3.1 Change the time unit for the flow rate display [UNIT] m (minute), h (hour), s (second).

3.2 Change the decimal place [DEC] 0 to 3.

3.3 Change the gate time [GATE] 0.0 to 25.0 seconds.

The electronic unit measures the number of pulses that occur during a defined period of time. This period of time is known as the gate time [GATE].

The display shows OFF if it is set to 0.0 s.

The flow rate is calculated together with the calibration constant [CAL] and the defined time unit for the display [UNIT].

The longer the gate time selected, the more precise will be the display although the updating of the display will slow down accordingly.

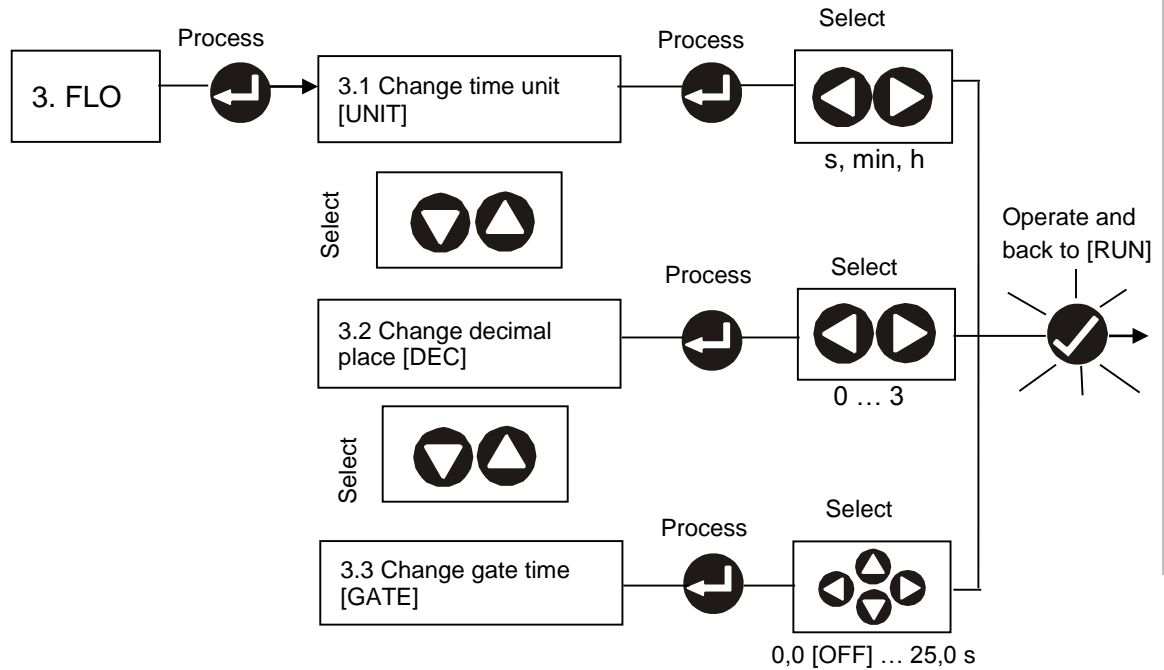

4. CAL

Display of calibration constants

Setting range: 0.9999999 to 99.99999

4.1 Select the memory location of the calibration constants [CAL] 0 to 9

There are 10 memory locations.

The settings of SET, UNIT and DEC can vary at each memory location. The displayed unit of volume of the total volume display and the flow rate display depends on the setting of the calibration constants at [UNIT]. This means that not only can the calibration be changed by the selection of the memory location but also the volume unit.

4.2 Set the calibration constants at the selected memory location [SET]

4.3 Set the volume unit of the calibration constants at the selected memory location [UNIT]

4.4 Set the decimal place of the calibration constants at the selected memory location [DEC].

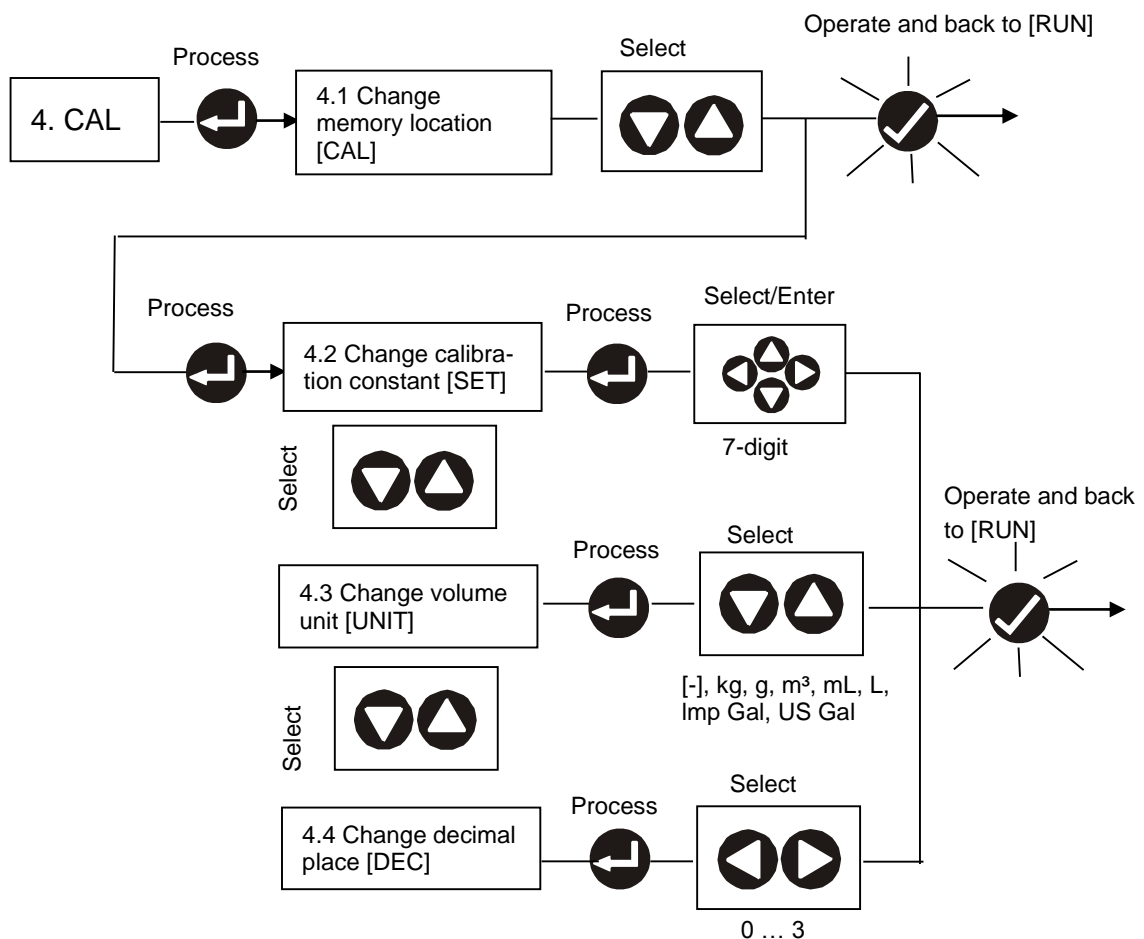

The volume display and the total volume are deleted by changing the calibration constants.

5. SET

General settings

5.1 Change security level [LOC]

The LOC setting can be used to protect the ranges from inadvertent changes. There are 5 security levels, "0" meaning no security and "4" meaning maximum security.

	Area				
LOC	RUN	TOT	FLO	CAL	SET
4	PIN	PIN	PIN	PIN	PIN
3	OK	PIN	PIN	PIN	PIN
2	OK	OK	PIN	PIN	PIN
1	OK	OK	OK	PIN	PIN
0	OK	OK	OK	OK	OK

5.2 Change PIN number [PIN].

A 3-digit PIN number can be issued once the security level has been selected. This PIN number must then be entered each time that a protected range is processed. The PIN number can also be "000".

Forgotten your PIN?



Not in hazardous areas!

Reset security level [LOC] to 0 and

Reset PIN number to "000"

All other entries are retained.

1. Remove battery from the battery compartment.
2. Press the Stop key before inserting the battery and hold it down while it is being inserted.

5.3 Change pulse redirection []

Pulse redirection is intended for other applications or units that can also process the input pulse from the electronic analysis unit. The input pulse is processed by the electronic analysis unit and converted into a rectangular pulse without contact bounce and then emitted. An isolating amplifier with a NAMUR input, capable of switching up to 150 Hz, is needed to use this signal.

5.4 Reset all settings to default values [DEF]

The following settings are entered when all settings are reset to default values:

Area	Designation	Action
RUN	Volume to be filled	Deleted
RUN	Decimal place [DEC]	1
TOT	Total volume	Deleted
TOT	Decimal place [DEC]	0
FLO	Time unit [UNIT]	min
FLO	Decimal place [DEC]	0
FLO	Gate time [GATE]	3.0 s
CAL	Memory [CAL]	0
CAL	Setting value [SET]	All memories to 0.0500000
CAL	Unit [UNIT]	All memories to "L"
CAL	Decimal place [DEC]	0
SET	Security level [LOC]	0
SET	PIN number [PIN]	000
SET	Pulse redirection []	"OFF"

5.5 Information on software version and other information.

No.	Designation
01	Software version currently used
02	Battery replacement counter

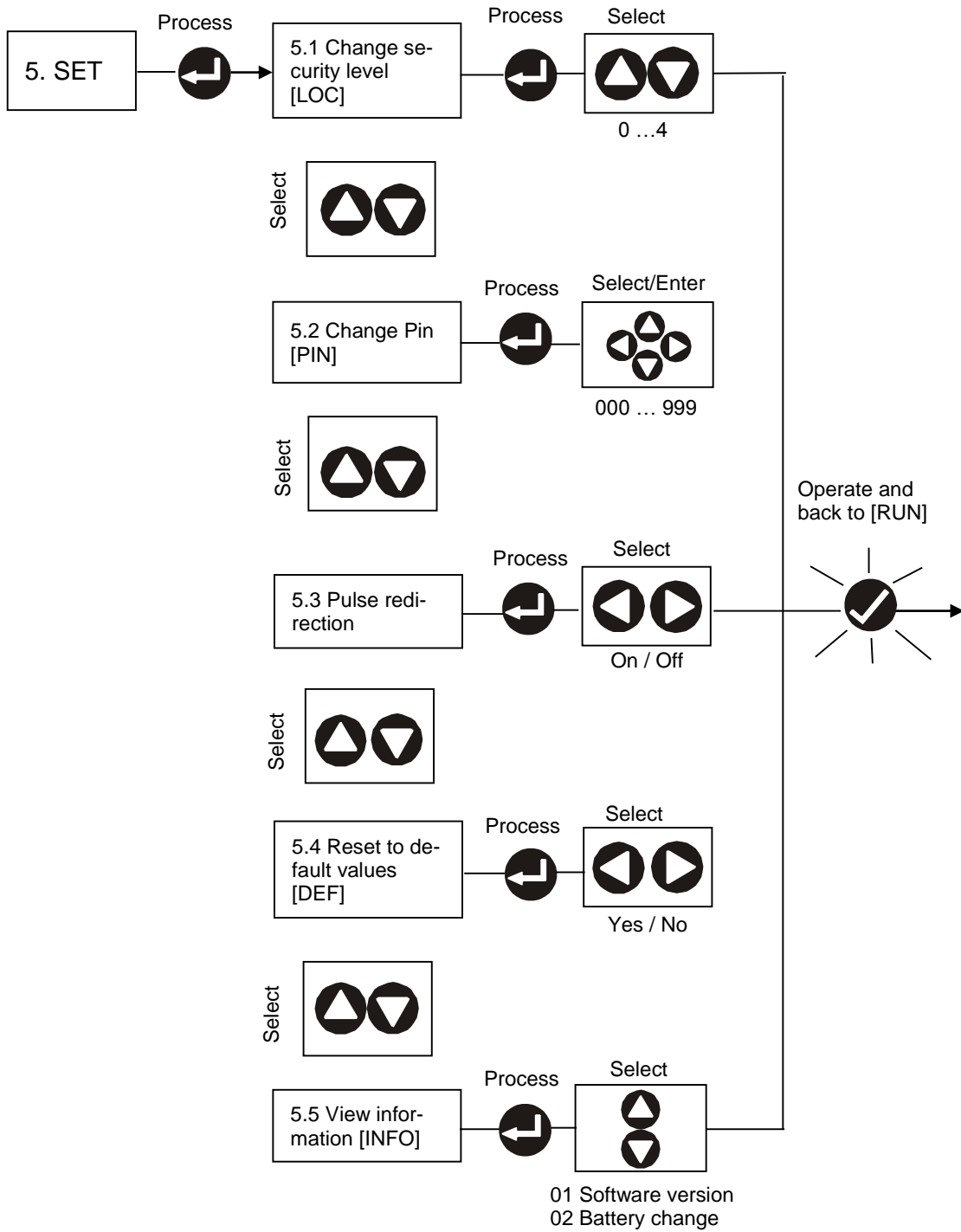

4 Technical data

Explosion protection marking:
 II 2 G Ex i a IIB T6 Gb
 PTB 11 ATEX 2005
 Electrical Data see
 Certificate of Acceptance

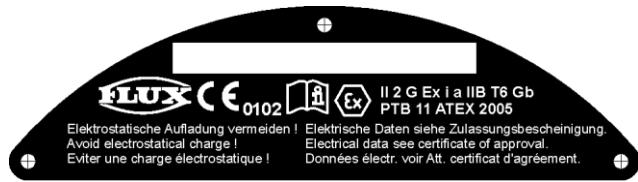

Storage temperature -25°C up to max. +70°C
 Surrounding temperature -20°C* up to max. +40°C
 *At temperatures below 0°C the LCD display is slowed down.

Material: Electronic unit housing PP; Display PSU; Panel PP

Battery: Lithium CR 2032 from Varta (Please only use the battery indicated in the EC-type-Examination-Certificate in the Original Main Operating Instructions Flow Meter FMC)
 Service life: 1 to 2 years, depending on use

Sensor input: Mechanical contact
 Frequency max. 150 Hz at pulse length of at least min. 0.8 ms

Pulse redirection (PIN 1): NAMUR output.
 A NAMUR isolating amplifier with an input and output transistor is needed to use the output.
 Frequency max. 150 Hz
 Pulse length set with 2 ms regardless of the frequency

Assignment of the 9-pin contact strip			
PIN No.	Colour	Short description	Description
1	yellow	IMP OUT	NAMUR Exit pulse redirection
6 ^{*1}	grey	IMP IN	Input external pulses (Reed switch) It is switched with +3V (9).
8	white	GND	Minus connection (for NAMUR exits)
9	brown	+ 3 V	Plus connection (for entry 6)

*1 When using the input for an external sensor the plug of the integrated sensor has to be unplugged.



Attention - not permitted in hazardous areas!
 In case of an external power supply use PIN 8 Minus and PIN 9 Plus.

Assignment of the 5-pin version

See technical data in the original attachment FLUXTRONIC® automatic mode.

Examples:

The flow meter is only suitable for use in normal mode.

The display is switched off when the flow meter is delivered.

The display can be switched on again by pressing a key.

By pressing the Stop key several times, the user can ensure that the unit has changed over to "RUN: Filling volume is displayed".

1. The total volume should be displayed with a decimal place.

Use the Down key to switch to "TOT: The total volume is displayed"

Press Process key.

Select using the Down key [DEC].

Press Process key again.

Use the left key to set the flashing decimal point to one decimal place.

Press the Operate key.

The display is now in "RUN: The filling volume is displayed".

2. The volume unit is to be shown once in litres and another time in kilograms.

The volume unit is assigned to the calibration constant and is therefore set in

"CAL0: The current calibration constant is displayed".

When delivered, a calibration constant is set at memory location 0 that was determined in the factory using water (e.g. .0498765 l/pulse).

If the display is to show kg, either the density of the liquid must be known so that the calibration constant can be converted from litre/pulse to kg/pulse, or weighing scales are used to determine the mass of the volume filled.

For example the density of the liquid is 1.2 kg/l, therefore the new calibration constant is $0.0498765 \text{ l/pulse} \times 1.2 \text{ kg/l} = 0.0598518 \text{ kg/pulse}$.

Or use the flow meter to fill a sufficiently large volume into a bucket, for instance (display on the flow meter shows 25.4 litres). The weight of 30.48 kg can be read on the scales.

The density of the liquid is now known to be $= 30.48 \text{ kg} / 25.4 \text{ litre} = 1.2 \text{ kg/litre}$.

Therefore again $0.0498765 \text{ l/pulse} \times 1.2 \text{ kg/l} = 0.0598518 \text{ kg/pulse}$

The new calibration constant is to be saved at memory location 1.

When the calibration constants are changed, the display of the volume filled and the total volume is reset.

Use the Down key to switch to "CAL0: The current calibration constant is displayed".

Press Process key.

Use the Up or Down key to set the memory location to 1.

Press Process key.

As you are now in the [SET] menu item, press the Process key again.

Using the left/right keys, select the relevant digit and enter the value of the digit using the Up/Down keys.

.0598518

Press the Operate key.

The display is now in "RUN: The filling volume is displayed".

To adjust the unit, use the Down key to change to "CAL0: The current calibration constant is displayed".

(CAL 1 / .0598518)

Press the Process key.

The memory location remains at 1.

Press the Process key.

Select using the [UNIT] menu item using the Down key.
Press the Process key.
Use the Up or Down key to set to "Kilogram".
Press the Operate key.
The display is now in "RUN: The filling volume is displayed".

To now switch to the calibration constant at memory location 0 (.0498765) with the litre unit, change the memory location now from 1 to 0.
Use the Down key to switch to "CAL0: The current calibration constant is displayed".
Press Process key.
Use the Up or Down key to set the memory location to 0.
Press the Operate key.
The display is now in "RUN: The volume to be filled is displayed".

And back to kg with the calibration constant (.0598518) -->
Select memory location 1 again.

3. The user can delete the volume filled and also change the decimal place in the display but cannot change the other settings.

To do so, enter settings in " SET: General Settings".
In chapter 5.1 "Change security level", the table shows that [LOC] Level 3 should be set.
All groups with the exception of RUN can only be processed by entering the PIN.

Use the Up key to switch to "SET: General Settings".
Press Process key.
As you are now in the [LOC] menu item, press the Process key again.
Use the Up or Down key to set the [LOC] level to 3.
The display is now again in "RUN: The volume to be filled is displayed".
A PIN can now be defined (default = "000").

Use the Up key to switch to "SET: General Settings"
Press Process key.
The PIN is still "000", therefore press Operate.
Select the [PIN] menu item using the Down key.
Press the Process key.
Using the left/right keys, select the relevant digit and enter the value of the digit using the Up/Down keys.
Press the Operate key.
The display is now in "RUN: The volume to be filled is displayed".
From now on, items 2 to 5 can only be processed via the PIN

5 Change of FLUXTRONIC® or battery



Change battery only outside the hazardous area!

Unscrew the four Torx screws (torque max. 1.3 Nm)



Pull the plug of the reed sensor out of the electronic unit

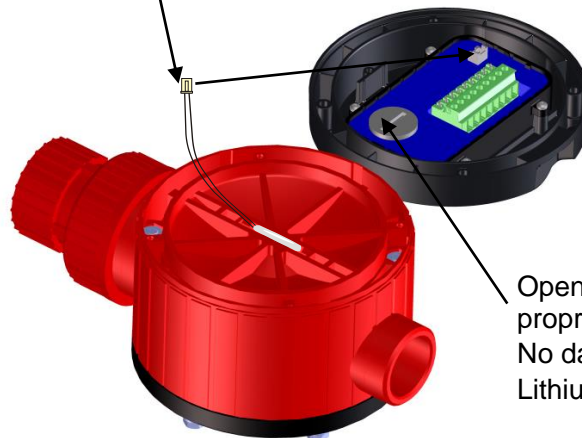

Open the battery compartment using an appropriate tool.
No data is lost when the battery is changed.
Lithium battery CR 2032 from Varta

When the battery capacity is almost empty, the information line shows "LOW BATT" alternatively with the current line. When this is the case, the electronic unit can run normally for up to 2 weeks.

When the battery capacity is so low that processing can no longer be reliably guaranteed, the display only shows "LOW BATT" and the functions are no longer operated

6 Commissioning



Attention!

- > If the material of the flow meter is not resistant to the liquid to be transferred, it must not be used.
- > Observe the chemical resistance and internal operating instructions.



Note!

- > Check if the materials of the flow meter are appropriate for the applications.



Note!

- > Generally replace a defect signalling cable.

7 In operation

Regularly check the flow meter for function.

8 Repair



Warning!

When non-approved spare-parts are used persons can be hurt and the machine/equipment can be damaged.

- > Only use spare and wear parts that are approved by the manufacturer.

- > Depressurise the system.
- > Separate pump from current.
- > Empty hose, flow meter and valves.
- > Always replace defective parts.
- > Only use genuine spare parts.

9 Disposal

Dispose of batteries/rechargeable batteries only in a discharged state, if possible. In order to avoid short circuits at not completely discharged batteries/rechargeable batteries, cover the terminals with tape.

Do not throw batteries/rechargeable batteries into the household waste, fire or water.

The batteries/rechargeable batteries must be disposed of in an environmentally sound manner.

Only for countries of the EC: Do not throw batteries/rechargeable batteries into the household waste. According to the European Directive 2006/66/EC defective and used batteries must be recycled. Accessories and packaging should be supplied for an environment-friendly recycling.



FLUX-GERÄTE GMBH

Talweg 12 · D-75433 Maulbronn

Tel +49 7043 101-0 · Fax +49 7043 101-444

info@flux-pumpen.de · www.flux-pumps.com