



# Epec EC44 Control Unit

Technical Document

MAN000713

---

---



Hardware version EC44C00

## DOCUMENT VERSION HISTORY

Date	Notes
10.02.2020	First released version

Last build time 13:15 – 10 February 2020

Epec Oy reserves all rights for improvements without prior notice

## Table of Contents

<b>1</b>	<b>PREFACE</b> .....	<b>5</b>
1.1	<i>Use of Symbols</i> .....	5
1.2	<i>Required Skills</i> .....	6
1.3	<i>Safety Guidelines</i> .....	6
1.4	<i>Warranty</i> .....	6
1.5	<i>Limited Liability</i> .....	7
1.6	<i>Environmental Statement</i> .....	7
<b>2</b>	<b>PRODUCT OVERVIEW</b> .....	<b>8</b>
<b>3</b>	<b>TECHNICAL DATA</b> .....	<b>9</b>
<b>4</b>	<b>INPUT/OUTPUT SPECIFICATIONS</b> .....	<b>11</b>
4.1	<i>I/O List</i> .....	11
4.1.1	<i>Connector (X1)</i> .....	12
4.2	<i>AI/DI_type091</i> .....	15
4.2.1	<i>AI (analog input) mode</i> .....	15
4.2.2	<i>DI (digital input) mode</i> .....	15
4.2.3	<i>Electrical characteristics</i> .....	16
4.2.4	<i>Functional block diagram</i> .....	16
4.3	<i>AI/DI/PI_type096</i> .....	17
4.3.1	<i>AI (analog input) mode</i> .....	17
4.3.2	<i>DI (digital input) mode</i> .....	17
4.3.3	<i>PI (pulse input) mode</i> .....	17
4.3.4	<i>Electrical characteristics</i> .....	18
4.3.5	<i>Functional block diagram</i> .....	19
4.4	<i>PWM/DO/CM 3 A_type114_2_0</i> .....	20
4.4.1	<i>PWM/DO (output) Mode</i> .....	20
4.4.2	<i>High Side Current Measurement</i> .....	20
4.4.3	<i>Electrical Characteristics</i> .....	20
4.4.4	<i>Functional Block Diagram</i> .....	21
4.5	<i>REF Output 5V/10V type_128_3_0</i> .....	22
4.5.1	<i>Protection Features</i> .....	22
4.5.2	<i>Voltage Monitoring</i> .....	22
4.5.3	<i>Electrical Characteristics</i> .....	22
4.5.4	<i>Functional Block Diagram</i> .....	23
4.6	<i>Power Supply</i> .....	24
4.6.1	<i>Overvoltage Protection</i> .....	24
4.6.2	<i>Power Consumption</i> .....	24
4.6.3	<i>Power supply pins</i> .....	24
4.6.4	<i>Electrical characteristics</i> .....	25
<b>5</b>	<b>BUS CONNECTIONS</b> .....	<b>26</b>
5.1	<i>CAN Bus</i> .....	26
5.1.1	<i>CAN Interface</i> .....	26
5.1.2	<i>CAN Bus Connection Pins</i> .....	26
5.1.3	<i>Functional block diagram</i> .....	26
<b>6</b>	<b>DIAGNOSTICS</b> .....	<b>27</b>
6.1	<i>LED Indicator</i> .....	27
6.2	<i>Temperature Monitoring</i> .....	30
6.2.1	<i>PCB area temperature</i> .....	30
6.3	<i>Supply Voltage Monitoring</i> .....	30
<b>7</b>	<b>APPROVALS</b> .....	<b>31</b>
7.1	<i>EMC tests</i> .....	31
7.2	<i>Environmental Tests</i> .....	38

Epec Oy reserves all rights for improvements without prior notice

<b>8</b>	<b>MECHANICS AND CABLING</b> .....	<b>42</b>
	8.1 <i>Unit Dimensions</i> .....	42
	8.2 <i>Plugging and unplugging the connectors</i> .....	43
	8.2.1 <i>Connector components</i> .....	44
	8.2.2 <i>Inserting contacts</i> .....	45
	8.2.3 <i>Removing contacts</i> .....	45
	8.2.4 <i>Connector component details</i> .....	46
	8.2.5 <i>Additional documentation</i> .....	47
	8.3 <i>Mounting and Cleaning</i> .....	48
	8.4 <i>Cabling</i> .....	50
	8.4.1 <i>System Topologies</i> .....	50
	8.4.2 <i>CAN Bus Cabling</i> .....	53
	8.4.3 <i>I/O Cabling</i> .....	55
	8.4.4 <i>Power Supply Cabling</i> .....	58
	8.5 <i>Welding</i> .....	60
	8.6 <i>Accessories and Ordering Codes</i> .....	61
	8.6.1 <i>LEAVYSEAL Tools</i> .....	67
	8.6.2 <i>LEAVYSEAL Contacts</i> .....	69
	8.6.3 <i>Wire Seals</i> .....	71
	8.6.4 <i>Sealing Plugs</i> .....	72
<b>9</b>	<b>GLOSSARY</b> .....	<b>73</b>

Epec Oy reserves all rights for improvements without prior notice

# 1 PREFACE

---

## 1.1 Use of Symbols

This manual uses the following symbols to point out important information or safety instructions:



The information icon indicates important information and issues to be noted for the reader.



The caution icon indicates very important information or a warning. If the advices are ignored, it can result in personal injury or damage to software or equipment.



The (electrical) warning icon indicates a hazard which could cause an electrical danger and/or a personal injury.

The following symbols may be used on Epec's product labels:



**CE compatibility**  
This symbol indicates that the product complies with the requirements set in the CE Standard.



**WEEE symbol**  
This symbol indicates that the product must be sent to separate collection facilities for recovery and recycling when the end-user wishes to discard the product.



**E17 Approval**  
This symbol indicates that the product is certified with normal automotive (E17) EMC (electromagnetic compatibility) standards.

Epec Oy reserves all rights for improvements without prior notice

## 1.2 Required Skills

The user of this document must have basic knowledge of machine controlling and CAN communication.

Refer to CAN and CANopen documentation from CAN in Automation (CiA) for further information on communication issues.

## 1.3 Safety Guidelines

The user of this documentation should follow general machine safety guidelines, directives and regulation appropriate to their country or market area.

A separate safety analysis is always for the machine and its control system. The features of this product should be well documented in machine and control system documents so that the machine operator has the right information how to operate the machine correctly and safely.

This product is designed to be used only for machine controlling purposes. The manufacturer does not assume any responsibility for this product being fit for any particular application, unless otherwise expressly stated in writing by the manufacturer.

This product complies with those certifications and standards that are mentioned in this manual. The manufacturer does not guarantee that this product complies with any other certification, standard or test other than mentioned in this manual.

This product is not field serviceable, so it should not be opened in any situation.

External fuses should be installed for the product or the system power supply.

The system should be designed and constructed according to the Epec general mounting and cabling instruction document.

Epec Oy reserves a right to improve its products without a further notice.

## 1.4 Warranty

Information concerning the warranty of this product can be found from *Epec General Sales and Warranty Terms*.

For more information, contact [sales@epec.fi](mailto:sales@epec.fi)

Epec Oy reserves all rights for improvements without prior notice

### 1.5 Limited Liability

The manufacturer shall under no circumstances be liable for loss of production, loss of profit, loss of use or any other consequential damages and/or indirect losses, whatever their cause may be. In case claims based on product liability are brought against the Manufacturer for which claims the manufacturer may be liable, the manufacturer's liability is limited to the extent normally covered under normal product liability insurances.

The buyer shall compensate the manufacturer to the extent that the manufacturer might be liable to pay damages as a result of claims based on product liability according to paragraph above.

### 1.6 Environmental Statement

The manufacturer uses ISO 14001: 2015 environmental certified processes and materials to manufacture products. The manufacturer undertakes to arrange for the recycling and scrapping of the products that are returned to the manufacturer by the buyer and/or the products that are received by the Manufacturer in connection with maintenance services performed as a result of that repairing of the products is deemed by the Manufacturer to be inappropriate.

The manufacturer will charge a scrapping fee from the buyer according to the manufacturer's price list in force from time to time. No scrapping fee will, however, be charged for products that are received by the manufacturer during the warranty period.

### WEEE

This product complies with the European Community Directive 2012/19/EU on waste electrical and electronic equipment (WEEE) encouraging and setting specific criteria for the collection, handling and recycling of electric and electronic waste.

Epec Oy reserves all rights for improvements without prior notice

## 2 PRODUCT OVERVIEW

---



Epec EC44 is a new compact programmable control unit based on the new connector and housing concept. Epec EC44 has a powerful 32-bit processor and large internal memory for application and parameters. EC44 has 16 inputs and 16 outputs with high-side current measurement, two CAN buses and a status LED. EC44 is based on CODESYS3.5 programming and supports Epec PLC libraries, Epec MultiTool and CANmoon tools. EC44 Control Unit has a robust full aluminum housing with IP69 protection and a lever locking connector designed especially for high vibration environments.

Epec Oy reserves all rights for improvements without prior notice

### 3 TECHNICAL DATA

<b>Processor</b>	32 bit CPU, 160 MHz
<b>Memory</b>	Flash memory: total 8 Mbyte  RAM memory: 512 kByte + 1024 kByte (1024 kByte for PLCopen application variables)  Non-volatile memory: 8 kByte  PLCopen application size up to 1024 kByte
<b>Power</b>	Nominal supply voltage 12/24 VDC systems (9 ... 34 VDC)  Idle power consumption 3,2 W (+24 VDC, no external load)  Undervoltage reset 5,2 V  Overvoltage protection typical 36...70 VDC (transient 123 V)
<b>REF voltage outputs</b>	+5 / +10 V (selectable by application and switched on/off by application)
<b>Diagnostics</b>	Signal LED (green/red/blue) Supply voltage Unit temperature REF voltage monitoring
<b>Protection functions</b>	Overvoltage protection Short-circuit protection for outputs
<b>Programming</b>	CODESYS 3.5
<b>Protection class</b>	IP69
<b>Size / Outer dimensions</b>	150 x 80 x 62 mm 5.91 x 3.15 x 2.44 in
<b>Weight</b>	0,615 kg 1.356 lbs
<b>Case material</b>	Aluminum

Epec Oy reserves all rights for improvements without prior notice

<b>Operating temperature</b>	-40... +85°C -40...+185°F	
<b>Storage temperature</b>	-40... +85°C -40...+185°F	
<b>Connectors</b>	1 x LEAVYSEAL 46 pin	
<b>Communications / Interfaces</b>	2 x CAN 2.0 B	
<b>REF pins total</b>	1	
<b>GND pins total</b>	3	
<b>I/O pins total</b>	32	
<b>Outputs</b>	16 x	PWM/DO/CM 3 A (with high side current measurement up to 3 A) (sourcing, up to 3 A, PWM frequency by configuration)
<b>Inputs</b>	10 x	AI/DI (0-10 V / 0-22 mA selection by application)
	6 x	AI/DI/PI (AI 0-5 V, pull-up / pull-down selection by application) (DI pull-down) (PI pull-up / pull-down selection by application)

Epec Oy reserves all rights for improvements without prior notice

## 4 INPUT/OUTPUT SPECIFICATIONS

### 4.1 I/O List

The Epec EC44 Control Unit has one connector as shown in the following figure.

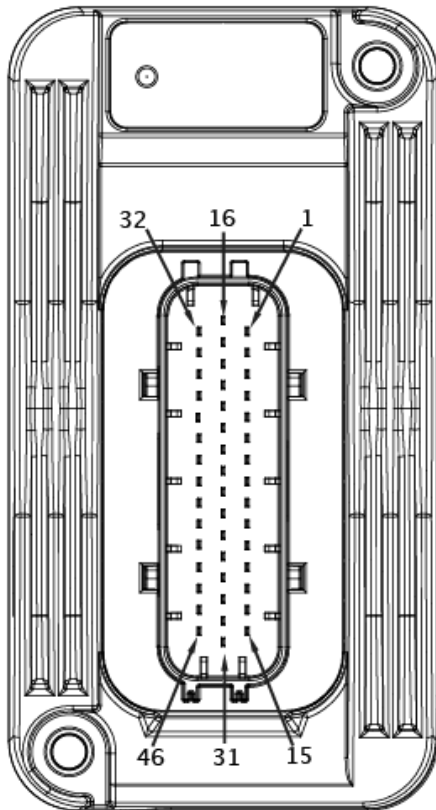

The following table lists the connector pins according to their pin number. Other columns offer quick information about the pin and links for more information.

\*\*Pair column: **UPPER CASE CHARACTERS** indicate outputs in the same physical component case.

Epec Oy reserves all rights for improvements without prior notice

#### 4.1.1 Connector (X1)

LEAVYSEAL 46 pin (A code)

##### 4.1.1.1 I/O table

Pin number	Pin type	Details	Pair**	Current /Voltage	Information
X1.1	<a href="#">Power Supply</a>				
X1.2	<a href="#">PWM/DO/CM 3 A_type114_2_0</a>	10 k $\Omega$ GND	E	3 A	
X1.3	<a href="#">PWM/DO/CM 3 A_type114_2_0</a>	10 k $\Omega$ GND	E	3 A	
X1.4	<a href="#">PWM/DO/CM 3 A_type114_2_0</a>	10 k $\Omega$ GND	F	3 A	
X1.5	<a href="#">PWM/DO/CM 3 A_type114_2_0</a>	10 k $\Omega$ GND	F	3 A	
X1.6	<a href="#">PWM/DO/CM 3 A_type114_2_0</a>	10 k $\Omega$ GND	G	3 A	
X1.7	<a href="#">PWM/DO/CM 3 A_type114_2_0</a>	10 k $\Omega$ GND	G	3 A	
X1.8	<a href="#">PWM/DO/CM 3 A_type114_2_0</a>	10 k $\Omega$ GND	H	3 A	
X1.9	<a href="#">PWM/DO/CM 3 A_type114_2_0</a>	10 k $\Omega$ GND	H	3 A	
X1.10	<a href="#">AI/DI_type091</a>	220 $\Omega$ GND / 80 k $\Omega$ GND		0..22 mA 0..10 V	
X1.11	<a href="#">AI/DI_type091</a>	220 $\Omega$ GND / 80 k $\Omega$ GND		0..22 mA 0..10 V	
X1.12	<a href="#">AI/DI_type091</a>	220 $\Omega$ GND / 80 k $\Omega$ GND		0..22 mA 0..10 V	
X1.13	<a href="#">AI/DI_type091</a>	220 $\Omega$ GND / 80 k $\Omega$ GND		0..22 mA 0..10 V	
X1.14	<a href="#">AI/DI_type091</a>	220 $\Omega$ GND / 80 k $\Omega$ GND		0..22 mA 0..10 V	
X1.15	<a href="#">AI/DI_type091</a>	220 $\Omega$ GND / 80 k $\Omega$ GND		0..22 mA	

				0..10 V	
X1.16	<a href="#">Power Supply</a>				
X1.17	GND				
X1.18	CAN 2 L TERM				
X1.19	CAN 2 L				
X1.20	CAN 2 H				
X1.21	CAN 1 L				
X1.22	CAN 1 H				
X1.23	CAN 1 L				
X1.24	CAN 1 H				
X1.25	Loader BSL Pin	For factory use only			
X1.26	GND				
X1.27	<a href="#">REF Output 5V/10V type_128_3_0</a>				
X1.28	<a href="#">AI/DI_type091</a>	220 Ω GND / 80 kΩ GND		0..22 mA 0..10 V	
X1.29	<a href="#">AI/DI_type091</a>	220 Ω GND / 80 kΩ GND		0..22 mA 0..10 V	
X1.30	<a href="#">AI/DI_type091</a>	220 Ω GND / 80 kΩ GND		0..22 mA 0..10 V	
X1.31	<a href="#">AI/DI_type091</a>	220 Ω GND / 80 kΩ GND		0..22 mA 0..10 V	
X1.32	GND				
X1.33	<a href="#">PWM/DO/CM 3 A_type114_2_0</a>	10 kΩ GND	A	3 A	
X1.34	<a href="#">PWM/DO/CM 3 A_type114_2_0</a>	10 kΩ GND	A	3 A	
X1.35	<a href="#">PWM/DO/CM 3 A_type114_2_0</a>	10 kΩ GND	B	3 A	
X1.36	<a href="#">PWM/DO/CM 3 A_type114_2_0</a>	10 kΩ GND	B	3 A	

X1.37	<a href="#">PWM/DO/CM 3 A_type114_2_0</a>	10 kΩ GND	C	3 A	
X1.38	<a href="#">PWM/DO/CM 3 A_type114_2_0</a>	10 kΩ GND	C	3 A	
X1.39	<a href="#">PWM/DO/CM 3 A_type114_2_0</a>	10 kΩ GND	D	3 A	
X1.40	<a href="#">PWM/DO/CM 3 A_type114_2_0</a>	10 kΩ GND	D	3 A	
X1.41	<a href="#">AI/DI/PI_type096</a>	2,2 kΩ +5 V/ 10 kΩ GND / 80 kΩ GND		0..5 V	
X1.42	<a href="#">AI/DI/PI_type096</a>	2,2 kΩ +5 V/ 10 kΩ GND / 80 kΩ GND		0..5 V	
X1.43	<a href="#">AI/DI/PI_type096</a>	2,2 kΩ +5 V/ 10 kΩ GND / 80 kΩ GND		0..5 V	
X1.44	<a href="#">AI/DI/PI_type096</a>	2,2 kΩ +5 V/ 10 kΩ GND / 80 kΩ GND		0..5 V	
X1.45	<a href="#">AI/DI/PI_type096</a>	2,2 kΩ +5 V/ 10 kΩ GND / 80 kΩ GND		0..5 V	
X1.46	<a href="#">AI/DI/PI_type096</a>	2,2 kΩ +5 V/ 10 kΩ GND / 80 kΩ GND		0..5 V	

## 4.2 AI/DI\_type091

Possible pin modes:

- +10 V AI voltage mode
- +20 mA AI current mode
- DI mode

Select the mode using MultiTool. MultiTool generates the needed code using functions from *SafeSSeriesIODriverExt* library. For more information refer to *Epec Programming and Libraries Manual* and *MultiTool Manual*.

### 4.2.1 AI (analog input) mode

- Pins can be configured either as a current input or as a voltage input by a library function:
  - Voltage mode: High impedance input for signal from 0 to 10 V
  - Current mode: Low impedance input for signal from 0 to 22 mA
- Pins can be used as e.g. joystick connection when the voltage mode is selected



When configured to current mode, the analog inputs shall be protected against prolonged overcurrent by using *SafeSSeriesHardware* programming library's function *S\_AIOverCurrentProtection*. For more information, refer to *Epec Programming and Libraries Manual*.

### 4.2.2 DI (digital input) mode

- These pins can also be used as digital inputs by using an application library
- The pin must be configured to voltage mode when using as digital input

Epec Oy reserves all rights for improvements without prior notice

### 4.2.3 Electrical characteristics

Symbol	Parameter	Conditions	Min	Max	Units
$V_i$	Input Voltage measuring range		0	10,5	V
$R_i$	Input Resistance	Voltage mode (referenced to GND)	typ. 80		k $\Omega$
$R_{SHUNT}$	Input Resistance	Current mode	typ. 220		$\Omega$
$I_i$	Input Current measuring range		0	22,7	mA
$I_E$	Full scale Input Error	Voltage mode		+/- 2	%
		Current mode		+/- 2	%
BW	First-order low pass filter cut-off frequency (-3 dB)	Voltage mode	typ. 2200		Hz
		Current mode	typ. 1200		Hz
$C_i$	Input pin capacitance		typ. 10		nF
$V_{I-range}$	Input voltage range	(Note 1)	-0,5	34	V
	Cable length			30	m

**Note 1:** Exceeding the max value might cause damage to input.

### 4.2.4 Functional block diagram

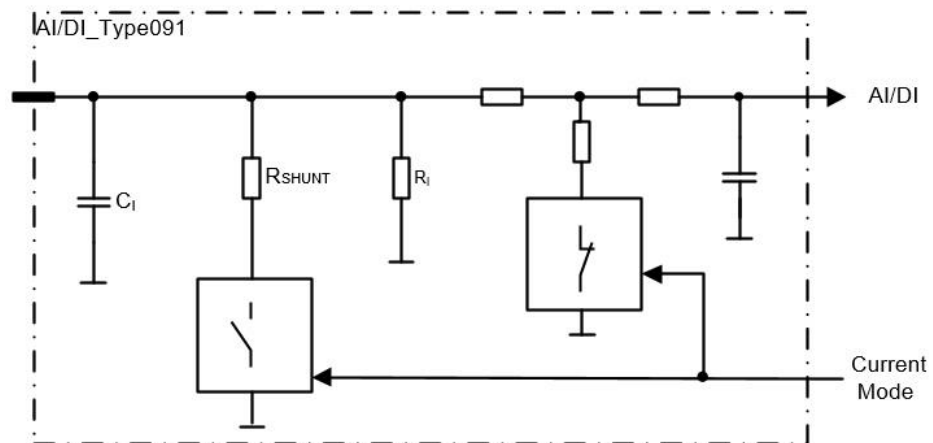

Epec Oy reserves all rights for improvements without prior notice

### 4.3 AI/DI/PI\_type096

Possible pin modes:

- +5 V AI mode
- DI mode
- PI mode

Select the mode using MultiTool. MultiTool generates the needed code using functions from *SafeSSeriesIODriverExt* library. For more information refer to *Epec Programming and Libraries Manual* and *MultiTool Manual*.

#### 4.3.1 AI (analog input) mode

- These pins have a pull-up/pull-down selection by a library function
- Pins can be used as high impedance voltage inputs for signals from 0 to 5 volts
- Pins can be used as e.g. joystick connection when AI mode without pull-up/pull-down is selected
- Pins can be used as e.g. resistive temperature sensor connection when AI mode with pull-up is selected

#### 4.3.2 DI (digital input) mode

- These pins can be used as digital inputs by using an application library
- The pin must be configured to DI mode when using it as a digital input. This enables a pull-down resistor to the ground

#### 4.3.3 PI (pulse input) mode

- This input mode has a pulse counting (PI), pulse width measuring, pulse frequency and pulse ratio features
- These pins have a pull-up/pull-down selection by a library function
- Pulse input mode can be used as a 1 or 2 channel pulse counter
  - 1 channel pulse counter, it is possible to use a specific pin as reset channel
  - 2 channel pulse counter, the reset feature is done by software. Refer to section *Programming E Series Units > I/O Programming > AI/DI/PI\_type096*
- Possible software channels and pairs are listed in section [I/O List](#) and in *Epec Programming and Libraries Manual*, section *Programming E Series Units > I/O Programming > AI/DI/PI\_type096*
- This mode is also suitable for quadrature sensor position counting

Epec Oy reserves all rights for improvements without prior notice

#### 4.3.4 Electrical characteristics

<i>Symbol</i>	<i>Parameter</i>	<i>Conditions</i>	<i>Min</i>	<i>Max</i>	<i>Units</i>
$V_I$	Input Voltage measuring range		0	6	V
$R_I$	Input Resistance	Voltage mode Referenced to GND	typ. 80		k $\Omega$
$R_{PD}$	Pull-down Resistance	DI mode	typ. 10		k $\Omega$
$R_{PU}$	Pull-up Resistance		2,18	2,22	k $\Omega$
$I_E$	Input Error	Voltage mode		+/- 2	%
BW	Input Low Pass Filter Bandwidth (-3 dB cut-off frequency)	Voltage mode	1600		Hz
$V_{IH}$	Input High Voltage	PI mode	3,6	34	V
$V_{IL}$	Input Low Voltage	PI mode	-0,5	1,4	V
$f_i$	Input Frequency (frequency measurement and pulse counting)	(Note 4)		20	kHz
$f_i$	Input Frequency (digital inputs)	(Note 2, 3)		1/ 2t <sub>c</sub>	kHz
t <sub>i</sub>	Input Pulse Width		0,1	500	ms
C <sub>i</sub>	Input Capacitance		typ. 1		nF
$V_{I-range}$	Input voltage range	(Note 1)	-0,5	34	V
	Cable length			30	m

**Note 1:** Exceeding the max value might cause damage to input.

**Note 2:** t<sub>c</sub> denotes the software cycle time in milliseconds.

**Note 3:** The pulse width must be greater than the software cycle time. For example with 50/50 pulse ratio, the pulse frequency is 1 / (2\*pulse width)

**Note 4:** The maximum value can be reached with 50 % duty cycle

Epec Oy reserves all rights for improvements without prior notice

**4.3.5 Functional block diagram**

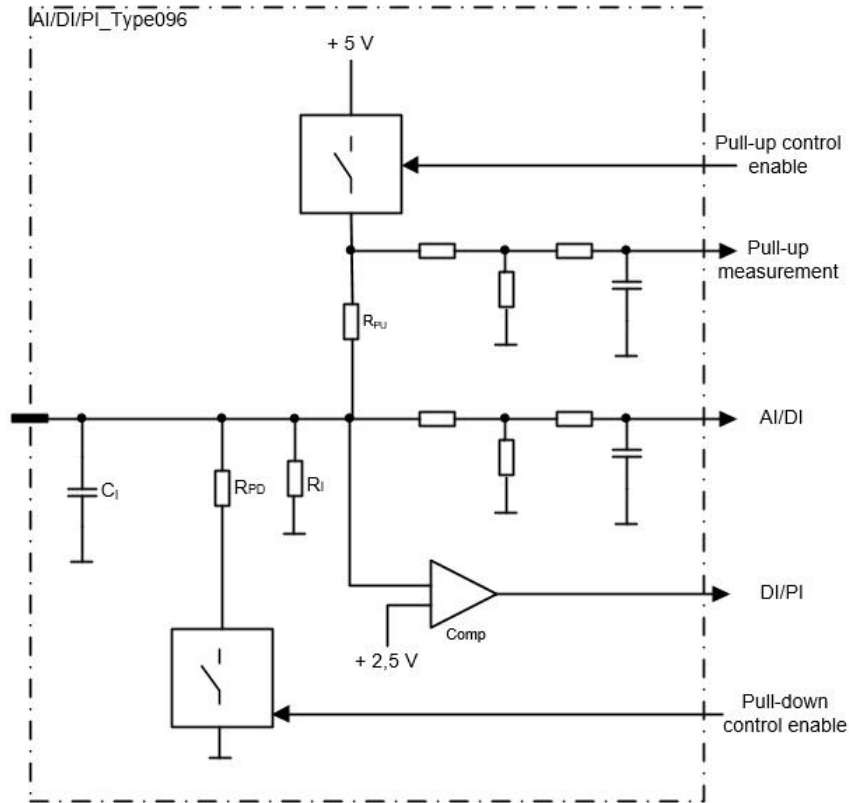

Epec Oy reserves all rights for improvements without prior notice

#### 4.4 PWM/DO/CM 3 A\_type114\_2\_0

Possible pin modes:

- PWM mode with high side current measurement
- DO mode

##### 4.4.1 PWM/DO (output) Mode

- This type of pin is a current sourcing output with a high side current measurement feature (the pin connects the load to a positive supply voltage through the shunt resistors).
  - These outputs have a switching element called a smart FET. It has integrated features to protect itself and also the external pin, wiring and actuator
  - These outputs are capable of generating pulse width modulated (PWM) output signals
  - The status feature indicates the possible output faults



The FET outputs are grouped into pairs:

- The maximum continuous current for a single output in the pair is 3 A.
- The maximum continuous current for the pair is 5 A.

The pairs are indicated with upper case characters in the pin table's **Pair** column in section [I/O List](#)

##### 4.4.2 High Side Current Measurement

- The application can control the current with a current measurement feature
- The firmware limits the maximum current to 3 A (when the current exceeds the value by more than the predefined time, the output is switched off)

##### 4.4.3 Electrical Characteristics

Symbol	Parameter	Conditions	Min	Max	Units
$R_{Shunt}$	Shunt resistance		typ. 25		mΩ
$I_{o-range}$	Nominal Current Measuring Range		0	3	A
$I_{acc-zero}$	Offset error	Calculated 'worst case'		+/-16	mA
$I_{acc-prop}$	Accuracy Proportional factor	Calculated 'worst case'		+/-2	% (FS)
$I_o$	Nominal Output Current	Output On (Note 4, 6)	0	3	A
$I_{o-lim-fw}$	Internal current limitation (fw)	Output On (Note 5)		3,2	A
$I_{o-lim-hw}$	Internal current limitation (hw)	Output On (Note 8)	typ. 56		A
$f_{PWM}$	PWM Frequency	In current control mode (Note 1)	10	500	Hz
		In PWM mode (Note 1)	10	3000	Hz

Epec Oy reserves all rights for improvements without prior notice

Duty <sub>PWM</sub>	PWM Duty cycle	(Note 2, 7)	0 to 100		%
Res <sub>PWM</sub>	PWM Resolution	(Note 3)	0,1		%
<b>Digital status</b>					
R <sub>i</sub>	Resistance	Output Off, referenced to U <sub>in2</sub>	10		kΩ
V <sub>IH</sub>	Input High Voltage		3,3	33	V
V <sub>IL</sub>	Input Low Voltage		-0,5	1,7	V
C <sub>O</sub>	Output pin capacitance		typ. 1		nF

**Note 1:** Frequency of a (PWM) Pulse Width Modulation is = 1 / Period

**Note 2:** The duty cycle is defined as the percentage of digital 'high' to digital 'low' signals present during a PWM period.

**Note 3:** The PWM resolution is defined as the maximum number of pulses that you can pack into a PWM period.

**Note 4:** The maximum output current depends on the load, PWM frequency and temperature.

**Note 5:** Firmware limits the maximum current to 3 A. When the current exceeds the value more than 20 ms, the output is switched off.

**Note 6:** When both outputs in the pair are used, the maximum continuous current for the pair is 5 A.

**Note 7:** When the frequency increases, the actual duty cycle may be bigger than the value that has been set.

**Note 8:** For high inrush currents hardware limitation reacts faster than firmware protection.

#### 4.4.4 Functional Block Diagram

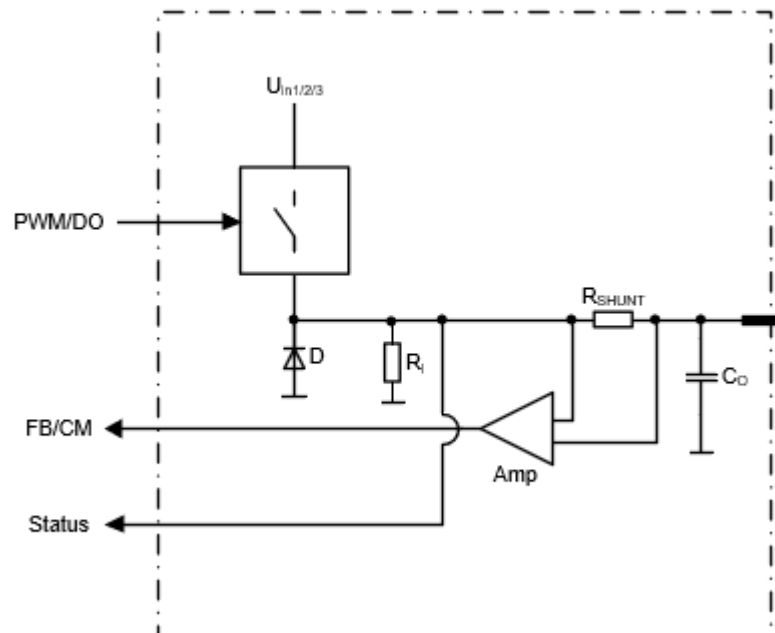

Epec Oy reserves all rights for improvements without prior notice

#### 4.5 REF Output 5V/10V type\_128\_3\_0

1. This is an internally regulated and monitored reference voltage supply for external devices
  - This reference output can be switched on/off by application
  - Output voltage can be selected by application (5V or 10V)

##### 4.5.1 Protection Features

- Overcurrent
- External voltage protection

##### 4.5.2 Voltage Monitoring

The level of the output voltage can be monitored.

##### 4.5.3 Electrical Characteristics

<i>Symbol</i>	<i>Parameter</i>	<i>Conditions</i>	<i>Min</i>	<i>Max</i>	<i>Units</i>
$V_{o-level}$	Output voltage	Output On; Unconnected pins	typ. 5 or 10		V
$I_o$	Nominal Output Current	Output On; Max total for all pins together	0	600	mA
$I_{o-lim}$	Internal Current Limitation	Output On (Note 2, 3)	typ. 1200		mA
$C_o$	Output Capacitance		typ. 22		uF
$V_{I-max}$	Max Input voltage	Overload conditions (Note 1)		34	V
<b><i>Voltage monitoring</i></b>					
$V_{I-range}$	Nominal Voltage measuring range		0	11	V

**Note 1:** When output voltage is under overload conditions, for example, short circuit to supply voltages. Exceeding the max value might cause damage to output.

**Note 2:** Current limit for overcurrent protection to limit internal power dissipation.

**Note 3:** When the limit is exceeded, the internal current limiter is activated.

Epec Oy reserves all rights for improvements without prior notice

**4.5.4 Functional Block Diagram**

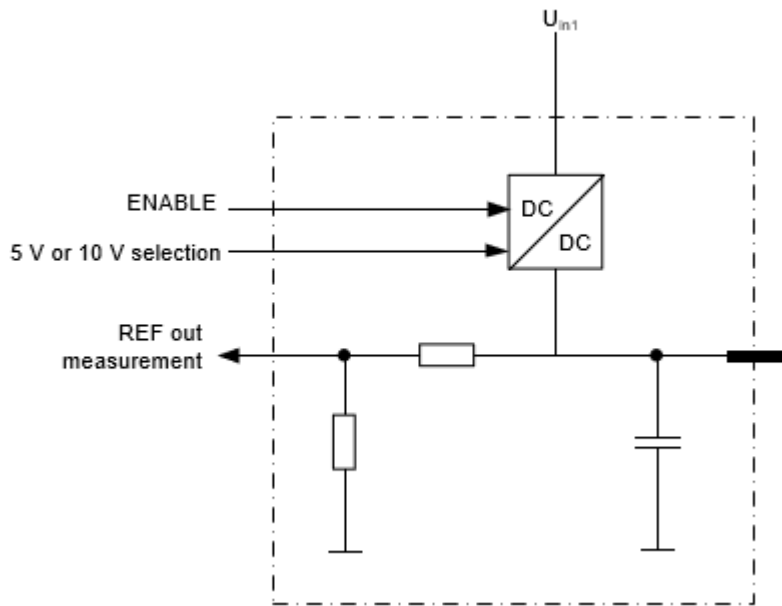

Epec Oy reserves all rights for improvements without prior notice

## 4.6 Power Supply

### 4.6.1 Overvoltage Protection

- Max. 70 VDC (stresses above this value may cause permanent damage to the unit.)
- The control unit has an overvoltage protection (OVP) which protects the unit and loads against overvoltage. The overvoltage protection is activated when the voltage reaches approximately 36 V.

### 4.6.2 Power Consumption

- < 3,2 W (+24 VDC, no external load)
- Supply Voltage ( $U_{in}$ ) maximum continuous current 20 A (with full external load)
- GND current sum max 20 A
- Maximum current per one GND and power pin is 15 A

### 4.6.3 Power supply pins

Use the power ground pins for the power supply return lines. The following table shows the power supply pin locations:

Designation	Connector / pin number	Potential
Supply voltage (for logic and power)	X1.1, X1.16	+12/+24 VDC
Power ground	X1.32	GND (15 A/pin)
Output ground	X1.17	GND (15 A/pin)
Sensor/Input ground	X1.26	GND (15 A/pin)
<b>Supply outputs</b>		
Reference supply (for external devices)	X1.27	+5 or +10 VDC / max 600 mA (max total for all pins together)



To ensure correct measurement, reserve separate GND pin(s) for AI pins and don't use it/them for any other purposes. For more information, see section [I/O Cabling](#).



Always use an external fuse to protect the control unit. The fuse is needed for overload protection. For more information, see section [Power Supply Cabling](#).

Epec Oy reserves all rights for improvements without prior notice

#### 4.6.4 Electrical characteristics

Symbol	Parameter	Conditions	Min	Max	Units
$V_I$	Nominal Input voltage		9	34	V
$I_{TOT-max}$	Max Total Current Output			20	A
$V_{I-Load-dump}$	Max Input transient Voltage level	(Note 1)		123	V
$V_{I-max}$	Max Continuous Input Voltage Level	(Note 2)	-0,5	70	V
$V_{OVP-Reg}$	Regulated Overvoltage threshold level		typ. 36		V
$V_{UVP}$	Undervoltage Threshold Level		typ. 5,2		V
$V_{RVP}$	Reverse Voltage Protection level		typ. -27		V
<b>Supply voltage monitoring</b>					
$V_{I-range}$	Nominal Input Voltage measuring range		0	52	V
$V_{I-prop}$	Measuring accuracy Proportional factor	Calculated		+/-2	%

**Note 1:** Load dump protection according to ISO 7637-2: 2004 pulse 5,  $U_s=+123$  V

**Note 2:** Limited functionality when the voltage is higher than the nominal. If the voltage is less than 6 V, the control unit is in non-operational state.

Epec Oy reserves all rights for improvements without prior notice

## 5 BUS CONNECTIONS

### 5.1 CAN Bus

#### 5.1.1 CAN Interface

- The physical interface of CAN interface is according to ISO 11898 and CAN 2.0B protocol
- The downloading of the PLCopen application can only be done via CAN1
- All interfaces support bit rates 50, 125, 250, 500, 800, 1000 kbit/s
- CAN1 and CAN2 are CANopen compatible and user programmable
- CANopen and SAE J1939 are available for both CANs
- 11-bit and 29-bit message receive and transmit are supported.
- Transmitting and receiving remote frames is supported in all CAN interfaces

CAN1 can be used for software downloading and CODESYS 3.5 communication. See *Epec Programming & Libraries Manual* for more information.

#### 5.1.2 CAN Bus Connection Pins

Designation	Pin number
CAN1 interface, system interface	X1.22 (CAN H) X1.24 (CAN H) X1.21 (CAN L) X1.23 (CAN L)
CAN2 interface	X1.20 (CAN H) X1.19 (CAN L) X1.18 (CAN L terminator)

#### 5.1.3 Functional block diagram

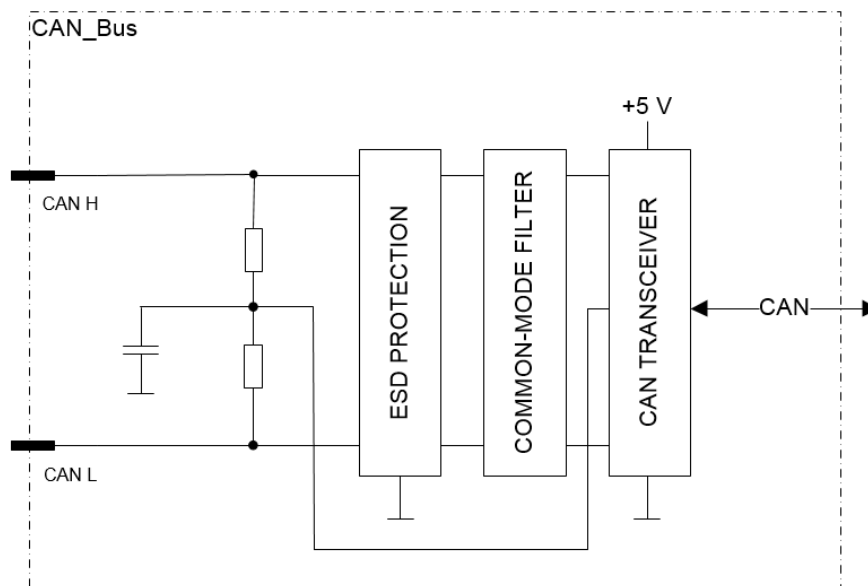

Epec Oy reserves all rights for improvements without prior notice

## 6 DIAGNOSTICS

---

### 6.1 LED Indicator

The LED indicator light is situated on the top side of the unit according to the following figure:

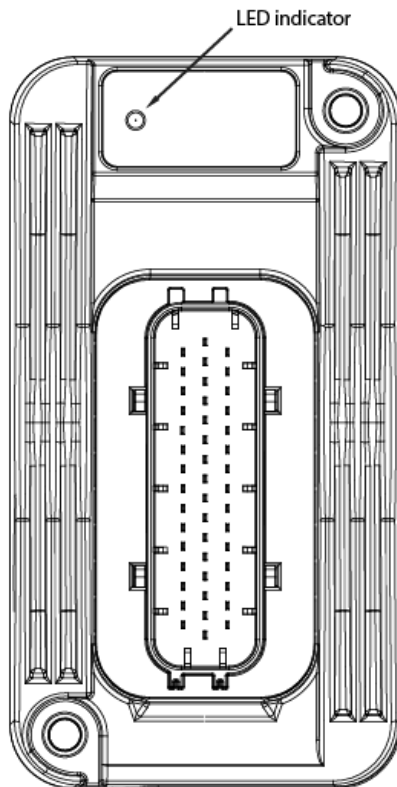

Some of the states must be implemented to application by using EXT programming library. For more information about EXT programming library, refer to *Epec Programming and Libraries Manual*.

Epec Oy reserves all rights for improvements without prior notice

Green, blue and red LED indicate different operating conditions according to the following table:

State	Green LED	Red LED	Blue LED	Implemented by	Explanation
Power off	-	-	-	-	No supply voltage
Power on and no SW running	-	ON	-	HW	Supply voltage is on, software is not running.
Power on and SW at init phase with no errors	ON	-	-	Boot/Firmware	Boot/Firmware is at init phase.
No application	5 Hz	-	-	Firmware	Firmware is running, no PLCopen application
Application stopped	ON	-	-	Firmware	Application is stopped. Depending on the application I/O configuration, firmware might diagnose this as an error situation, which leads to the red LED to turn ON.
Fatal error	-	ON	-	Boot/Firmware/HW	Control unit boot-up failed or a critical error while running.
Update	Blinks alternately with red LED	Blinks alternately with green LED	-	Boot	After firmware update boot-up, during the installation phase, red and green LEDs are flashed alternately.
Update Successful	ON	-	ON	Boot	After new firmware is successfully installed, green and blue LEDs are set ON. Reboot is required.
Erasing	ON	ON	-	Boot	During new firmware installation, LED is yellow when downloaded firmware is being erased

Application init	ON	-	-	Application	LED is continuously on also during the initialization: starting from power on until the application is running and the I/O / CAN initializations are done.
ApplicationOk + No Safe Operational	-	-	2 Hz	Application	Application is running and the system is OK and in safe state (safety switches are open – no voltage is provided to outputs)
ApplicationOk + Safe Operational	2 Hz	-	-	Application	Application is running and the system is OK and in safe operational state (safety switches are closed)
Application Error (system not OK)	-	2 Hz	-	Application	Application error. The system is not OK.
Unit Configuration	-	-	5 Hz	Firmware	Blue LED is blinking. The unit is in configuration state, Global Failsafe Command (GFC) has been sent and the correct password has been set through CAN. In this state, it is possible to change configuration parameters and download binaries to the unit.
Application custom control	Application specific	Application specific	Application specific	Application	Application can override code template's LED control by application specific implementation

## 6.2 Temperature Monitoring

### 6.2.1 PCB area temperature

This temperature measurement point monitors the PCB area temperature.

Symbol	Parameter	Conditions	Min	Max	Units
$PCB_{Temp}$	Nominal PCB Temperature measuring range		-40	125	°C
$T_{prop}$	Temperature measuring accuracy Proportional factor		+/-5		%

## 6.3 Supply Voltage Monitoring

The supply voltage of the control unit can be monitored.

Symbol	Parameter	Min	Max	Units
$U_{in}$	Nominal Supply Voltage Measuring Range	0	52	V
<b>Diagnostics</b>		<b>Low</b>	<b>High</b>	<b>Units</b>
	Recommended Supply Voltage Warning Level	10	30	V

For additional electrical characteristics refer to section [Power Supply](#).

Epec Oy reserves all rights for improvements without prior notice

## 7 APPROVALS

### 7.1 EMC tests

Epec EC44 Control Units are certified according to EMC tests that are described in this section.

The following tables provide a summary of performed EMC tests:

#### Emission tests according to the test specification EN 61000-6-3 (2007), Amd. A1 (2011)

Emission test	Test method
Radiated Emissions, Class B	EN 55016-2-3
Conducted Emissions from the Mains Cable, Class B	EN 55016-2-1

#### Immunity tests according to the test specification EN 61000-6-2 (2005)

Immunity test	Test method
Electrostatic discharge (ESD)	EN 61000-4-2
	ISO 10605
Radiated radio-frequency electromagnetic field	EN 61000-4-3
Electrical fast transients (EFT/B)	EN 61000-4-4
Surges	EN 61000-4-5
Conducted radio-frequency field immunity	EN 61000-4-6
Power frequency magnetic field immunity	EN 61000-4-8

#### Emission tests according to the E/ECE Regulation No. 10, Revision 5

Emission test	Test method	Conclusion
Measurement of radiated interference field strength in the frequency range 30 - 1000 MHz	CISPR 25	Pass <sup>1)</sup>
Measurement of conducted disturbances	ISO 7637-2	Pass <sup>2)</sup>

<sup>1)</sup> Limit values according to the E/ECE Regulation No. 10, rev 5

<sup>2)</sup> Limit values according to the E/ECE Regulation No. 10, rev 5

#### Immunity tests according to the E/ECE Regulation No. 10, Revision 5

Immunity test	Test method	Conclusion
Radiated radio-frequency electromagnetic field	ISO 11452-2, ISO 11452-4	Pass <sup>1)</sup>
Immunity to transient disturbances conducted along supply lines	ISO 7637-2	Pass <sup>2)</sup>

<sup>1)</sup> The requirements defined in the E/ECE Regulation No. 10, rev 5

<sup>2)</sup> The requirements defined in the E/ECE Regulation No. 10, rev 5

Epec Oy reserves all rights for improvements without prior notice

The following tables provide more detailed descriptions about the performed EMC tests:

Emission tests according to the E/ECE Regulation No. 10, Revision 5									
Radiated disturbance emission test	<ul style="list-style-type: none"> <li>Test method E/ECE Reg. No. 10, Annexes 7 and 8, CISPR 25</li> </ul> <table border="1" style="margin-left: 40px;"> <thead> <tr> <th>Frequency (MHz)</th> <th>Limit value (dBmV/m)</th> </tr> </thead> <tbody> <tr> <td>30 - 1000</td> <td>62/52/63 (Broadband QP)</td> </tr> <tr> <td>30 - 1000</td> <td>52/42/53 (Narrowband AVE)</td> </tr> </tbody> </table>	Frequency (MHz)	Limit value (dBmV/m)	30 - 1000	62/52/63 (Broadband QP)	30 - 1000	52/42/53 (Narrowband AVE)		
Frequency (MHz)	Limit value (dBmV/m)								
30 - 1000	62/52/63 (Broadband QP)								
30 - 1000	52/42/53 (Narrowband AVE)								
Conducted disturbances emission test	<ul style="list-style-type: none"> <li>Test method E/ECE Reg. No. 10, Annex 10, ISO 7637-2: 2004/Amd.1:2008</li> </ul> <table border="1" style="margin-left: 40px;"> <thead> <tr> <th>Port</th> <th>Limit level (V)</th> </tr> </thead> <tbody> <tr> <td rowspan="2">13,5 V DC input</td> <td>+75</td> </tr> <tr> <td>-100</td> </tr> <tr> <td rowspan="2">27 V DC input</td> <td>+150</td> </tr> <tr> <td>- 450</td> </tr> </tbody> </table>	Port	Limit level (V)	13,5 V DC input	+75	-100	27 V DC input	+150	- 450
Port	Limit level (V)								
13,5 V DC input	+75								
	-100								
27 V DC input	+150								
	- 450								

Epec Oy reserves all rights for improvements without prior notice

**Immunity tests according to the E/ECE Regulation No. 10, Revision 5**

Immunity to transient disturbances conducted along supply lines test

- Test method E/ECE Reg. No. 10, Annex 10, ISO 7637-2: 2004/Amd.1:2008

- Performance criterion:

Pulse	Criterion
1	C
2a	A
2b	C
3a	A
3b	A
4	C (12 V) A (24 V)
5a	C

- 12 V input, Pulse:

Pulse	Pulse parameters
1	-75 V, $R_i$ 10 $\Omega$ , 2 s, 5000 pulses
2a	+37 V, $R_i$ 2 $\Omega$ , 0,2 s, 5000 pulses
2b	+10 V, 220 ms, 10 pulses
3a	-112 V, 10/90 ms, 60min
3b	+75 V, 10/90 ms, 60min
4	$t_d$ 25 ms, -6,0 V, 5 s, -2,5 V, 10 pulses

- 24 V input, Pulse:

Pulse	Pulse parameters
1	-450 V, $R_i$ 50 $\Omega$ , 2 s, 5000 pulses
2a	+37 V, $R_i$ 2 $\Omega$ , 0,2 s, 5000 pulses
2b	+20 V, 220 ms, 10 pulses
3a	-150 V, 10/90 ms, 60min
3b	+150 V, 10/90 ms, 60min
4	$t_d$ 50 ms, -12 V, 5 s, -5 V, 1 pulse
5a	$t_d$ 350ms, $R_i$ 1 $\Omega$ , +123 V, 1 pulse

Epec Oy reserves all rights for improvements without prior notice

Immunity of ESAs to electromagnetic radiation	<ul style="list-style-type: none"> <li>• Test method E/ECE Reg. No. 10, Annex 9, ISO 11452-2:2004, ISO 11452-4:2005, Cor 1: 2009</li> <li>• Performance criterion: A</li> </ul>				
	Specification	Step	Dwell time	Frequency Range (MHz)	Test level
	Modulation AM80% 1 kHz	5%	3 s	20-80	60 mA
	Modulation AM80% 1 kHz	2%	3 s	80-1000	30 V/m
	PM 577/4600 $\mu$ s	1%	3 s	800-1000	30 V/m (constant peak)
PM 577/4600 $\mu$ s	1%	3 s	1000-2000	30 V/m (constant peak)	
<p><b>Classification of functional status</b></p> <p><i>Class A:</i> All functions of a device/system perform as designed during and after exposure to disturbance.</p> <p><i>Class B:</i> All functions of a device/system perform as designed during and after exposure to disturbance. However, one or more of them can go beyond specified tolerance. All functions return automatically to within normal limits after exposure is removed. Memory functions shall remain class A.</p> <p><i>Class C:</i> One or more functions of a device/system do not perform as designed during exposure but return automatically to normal operation after exposure is removed.</p> <p><i>Class D:</i> One or more functions of a device/system do not perform as designed during exposure and do not return to normal operation until exposure is removed and a device/system is reset by simple "operator/use" action.</p> <p><i>Class E:</i> One or more functions of a device/system do not perform as designed during exposure and cannot be returned to operation without repairing the device/system.</p>					

Epec Oy reserves all rights for improvements without prior notice

<b>EN 61000-6-3 (2007), Amd. A1 (2011)</b> Electromagnetic compatibility-generic emission standard part6-3: residential, commercial and light industry											
Radiated disturbance emission test	<ul style="list-style-type: none"> <li>Test method EN 55016-2-3</li> </ul> <table border="1"> <thead> <tr> <th>Frequency (MHz)</th> <th>Limit value (dBmV/m)</th> </tr> </thead> <tbody> <tr> <td>30 - 1000</td> <td>30/37 (QP)</td> </tr> <tr> <td>1000 - 6000</td> <td>70/74 (QP)</td> </tr> </tbody> </table>	Frequency (MHz)	Limit value (dBmV/m)	30 - 1000	30/37 (QP)	1000 - 6000	70/74 (QP)				
Frequency (MHz)	Limit value (dBmV/m)										
30 - 1000	30/37 (QP)										
1000 - 6000	70/74 (QP)										
Conducted disturbance at main ports emission test	<ul style="list-style-type: none"> <li>Test method EN 55016-2-1</li> </ul> <table border="1"> <thead> <tr> <th>Frequency (MHz)</th> <th>Limit value (dBmV)</th> </tr> </thead> <tbody> <tr> <td>0,15 - 30</td> <td>66/56/60 (QP)</td> </tr> <tr> <td>0,15 - 30</td> <td>56/46/50 (AVE)</td> </tr> </tbody> </table>	Frequency (MHz)	Limit value (dBmV)	0,15 - 30	66/56/60 (QP)	0,15 - 30	56/46/50 (AVE)				
Frequency (MHz)	Limit value (dBmV)										
0,15 - 30	66/56/60 (QP)										
0,15 - 30	56/46/50 (AVE)										
<b>EN 61000-6-2 (2005)</b> Electromagnetic compatibility-generic immunity standard part6-2: industrial environment											
Conducted radio-frequency common mode immunity test	<ul style="list-style-type: none"> <li>Test method EN 61000-4-6</li> <li>Performance criterion A</li> </ul> <table border="1"> <thead> <tr> <th>Specification</th> <th>Port</th> <th>Test level</th> </tr> </thead> <tbody> <tr> <td rowspan="3">Frequency range 0,150-80 MHz, Modulation AM80% 1 kHz, Dwell time 2 s</td> <td>DC input port</td> <td>10 V<sub>RMS</sub></td> </tr> <tr> <td>Signal ports</td> <td>10 V<sub>RMS</sub></td> </tr> <tr> <td>IO ports</td> <td>10 V<sub>RMS</sub></td> </tr> </tbody> </table>	Specification	Port	Test level	Frequency range 0,150-80 MHz, Modulation AM80% 1 kHz, Dwell time 2 s	DC input port	10 V <sub>RMS</sub>	Signal ports	10 V <sub>RMS</sub>	IO ports	10 V <sub>RMS</sub>
Specification	Port	Test level									
Frequency range 0,150-80 MHz, Modulation AM80% 1 kHz, Dwell time 2 s	DC input port	10 V <sub>RMS</sub>									
	Signal ports	10 V <sub>RMS</sub>									
	IO ports	10 V <sub>RMS</sub>									
Radiated radio-frequency electromagnetic field immunity test	<ul style="list-style-type: none"> <li>Test method EN 61000-4-3</li> <li>Performance criterion A</li> </ul> <table border="1"> <thead> <tr> <th>Specification</th> <th>Range (MHz)</th> <th>Test level</th> </tr> </thead> <tbody> <tr> <td>Modulation AM 80% 1 kHz, Dwell time 2 s</td> <td>80-6000</td> <td>10 V/m</td> </tr> </tbody> </table>	Specification	Range (MHz)	Test level	Modulation AM 80% 1 kHz, Dwell time 2 s	80-6000	10 V/m				
Specification	Range (MHz)	Test level									
Modulation AM 80% 1 kHz, Dwell time 2 s	80-6000	10 V/m									

Epec Oy reserves all rights for improvements without prior notice

<p>Electrical fast transient (EFT) immunity test</p>	<ul style="list-style-type: none"> <li>• Test method EN 61000-4-4</li> <li>• Performance criterion B</li> </ul> <table border="1" data-bbox="903 371 1406 685"> <thead> <tr> <th>Test pulse</th> <th>Port</th> <th>Test level</th> </tr> </thead> <tbody> <tr> <td rowspan="3">Repetition frequency 5 kHz, Duration 1 minute</td> <td>DC input port</td> <td><math>\pm 2,0</math> kV</td> </tr> <tr> <td>Signal ports</td> <td><math>\pm 1,0</math> kV</td> </tr> <tr> <td>IO ports</td> <td><math>\pm 1,0</math> kV</td> </tr> </tbody> </table>	Test pulse	Port	Test level	Repetition frequency 5 kHz, Duration 1 minute	DC input port	$\pm 2,0$ kV	Signal ports	$\pm 1,0$ kV	IO ports	$\pm 1,0$ kV						
Test pulse	Port	Test level															
Repetition frequency 5 kHz, Duration 1 minute	DC input port	$\pm 2,0$ kV															
	Signal ports	$\pm 1,0$ kV															
	IO ports	$\pm 1,0$ kV															
<p>Surge Immunity</p>	<ul style="list-style-type: none"> <li>• Test method EN 61000-4-5</li> <li>• Performance criterion B</li> </ul> <table border="1" data-bbox="868 887 1441 1120"> <thead> <tr> <th>Specification</th> <th>Port</th> <th>Path</th> <th>Test level</th> </tr> </thead> <tbody> <tr> <td rowspan="2">Pulses: 5 Repetition rate: 60 s</td> <td rowspan="2">DC Input port</td> <td>Line to Line</td> <td><math>\pm 0,5</math> kV</td> </tr> <tr> <td>Line to Ground</td> <td><math>\pm 1,0</math> kV</td> </tr> </tbody> </table>	Specification	Port	Path	Test level	Pulses: 5 Repetition rate: 60 s	DC Input port	Line to Line	$\pm 0,5$ kV	Line to Ground	$\pm 1,0$ kV						
Specification	Port	Path	Test level														
Pulses: 5 Repetition rate: 60 s	DC Input port	Line to Line	$\pm 0,5$ kV														
		Line to Ground	$\pm 1,0$ kV														
<p>Electrostatic discharge (ESD) immunity test</p>	<ul style="list-style-type: none"> <li>• Test method EN61000-4-2</li> <li>• Performance criterion B</li> </ul> <table border="1" data-bbox="868 1279 1441 1547"> <thead> <tr> <th>Discharge mode</th> <th>Test level (kVp)</th> </tr> </thead> <tbody> <tr> <td>Contact</td> <td><math>\pm 2, \pm 4, \pm 6, \pm 8</math></td> </tr> <tr> <td>Indirect contact</td> <td><math>\pm 2, \pm 4, \pm 6, \pm 8</math></td> </tr> <tr> <td>Air</td> <td><math>\pm 2, \pm 4, \pm 6, \pm 8 \pm 15</math></td> </tr> </tbody> </table> <ul style="list-style-type: none"> <li>• Test method ISO 10605</li> <li>• Performance criterion B</li> </ul> <table border="1" data-bbox="903 1704 1406 1962"> <thead> <tr> <th>Discharge mode</th> <th>Test level (kVp)</th> </tr> </thead> <tbody> <tr> <td>Contact</td> <td><math>\pm 8, \pm 15</math></td> </tr> <tr> <td>Indirect contact</td> <td><math>\pm 8, \pm 15</math></td> </tr> <tr> <td>Air</td> <td><math>\pm 15 \pm 25</math></td> </tr> </tbody> </table>	Discharge mode	Test level (kVp)	Contact	$\pm 2, \pm 4, \pm 6, \pm 8$	Indirect contact	$\pm 2, \pm 4, \pm 6, \pm 8$	Air	$\pm 2, \pm 4, \pm 6, \pm 8 \pm 15$	Discharge mode	Test level (kVp)	Contact	$\pm 8, \pm 15$	Indirect contact	$\pm 8, \pm 15$	Air	$\pm 15 \pm 25$
Discharge mode	Test level (kVp)																
Contact	$\pm 2, \pm 4, \pm 6, \pm 8$																
Indirect contact	$\pm 2, \pm 4, \pm 6, \pm 8$																
Air	$\pm 2, \pm 4, \pm 6, \pm 8 \pm 15$																
Discharge mode	Test level (kVp)																
Contact	$\pm 8, \pm 15$																
Indirect contact	$\pm 8, \pm 15$																
Air	$\pm 15 \pm 25$																

Epec Oy reserves all rights for improvements without prior notice

Power frequency magnetic field immunity	<ul style="list-style-type: none"> <li>• Test method EN 61000-4-8</li> <li>• Performance criterion A</li> </ul> <table border="1" data-bbox="879 338 1426 573"> <thead> <tr> <th>Polarization</th> <th>Dwell time (min)</th> <th>Test level (A/m)</th> </tr> </thead> <tbody> <tr> <td>x</td> <td>5</td> <td>100</td> </tr> <tr> <td>y</td> <td>5</td> <td>100</td> </tr> <tr> <td>z</td> <td>5</td> <td>100</td> </tr> </tbody> </table>	Polarization	Dwell time (min)	Test level (A/m)	x	5	100	y	5	100	z	5	100
Polarization	Dwell time (min)	Test level (A/m)											
x	5	100											
y	5	100											
z	5	100											
<p><b>Performance criteria for immunity tests</b></p> <p><i>Performance criterion A:</i> The EUT shall continue to operate as intended during and after the test. No degradation of performance is allowed.</p> <p><i>Performance criterion B:</i> The EUT shall continue to operate as intended after the test. However, moderate degradation of performance is allowed. No change of actual operating state or loss of memory functions is allowed.</p> <p><i>Performance criterion C:</i> Temporary loss of function is allowed if the function is self-recoverable or can be restored by the operation of controls.</p>													

Epec Oy reserves all rights for improvements without prior notice

## 7.2 Environmental Tests

The following environmental tests have been performed to Epec EC44 Control Units:

Temperature			
Test	Temperature	Duration/ Exposure time	Remarks
Cold IEC 60068-2-1 :2007 Test Ae	-40 °C	16 h	<ul style="list-style-type: none"> <li>1 °C/min</li> </ul>
Cold IEC 60068-2-1 :2007 Test Ad	-40 °C	16 h	<ul style="list-style-type: none"> <li>1 °C/min</li> </ul>
Dry heat IEC 60068-2-2 :2007 Test Bd	+85 °C	16 h	<ul style="list-style-type: none"> <li>1 °C/min</li> </ul>
Dry heat IEC 60068-2-2 :2007 Test Be	+85 °C	16 h	<ul style="list-style-type: none"> <li>1 °C/min</li> </ul>
Damp heat cycling IEC 60068-2-30 (2005-08) Test Db	+25 °C/+55 °C	cycle duration 24 h	<ul style="list-style-type: none"> <li>rel. humidity &gt;90%</li> <li>six test cycles</li> </ul>
Change of temperature IEC 60068-2-14 (2009-01) Test Na	-50 °C/+60 °C	3 h	<ul style="list-style-type: none"> <li>change time between extreme temperatures was as fast as possible</li> <li>5 test cycles</li> </ul>
Change of temperature IEC 60068-2-14 (2009-01) Test Nb	-40 °C/+85 °C	3 h	<ul style="list-style-type: none"> <li>change of temperature 4 °C/min</li> <li>2 test cycles</li> </ul>

Epec Oy reserves all rights for improvements without prior notice

Mechanical resistance		
Test	Duration and direction	Remark
Shock test IEC 60068-2-27 (2008-02) Test Ea	<ul style="list-style-type: none"> <li>• pulse duration 6 ms</li> <li>• 500 impulses in every six directions</li> </ul>	<ul style="list-style-type: none"> <li>• half sine pulse shape</li> <li>• peak acceleration 500 m/s<sup>2</sup> (50g)</li> </ul>
Shock test IEC 60068-2-27 (2008-02) Test Ea	<ul style="list-style-type: none"> <li>• pulse duration 4 ms</li> <li>• 100 impulses in every six directions</li> </ul>	<ul style="list-style-type: none"> <li>• half sine pulse shape</li> <li>• peak acceleration 750 m/s<sup>2</sup> (75g)</li> </ul>
Shock test IEC 60068-2-27 (2008-02) Test Ea	<ul style="list-style-type: none"> <li>• pulse duration 4 ms</li> <li>• 100 impulses in every six directions</li> </ul>	<ul style="list-style-type: none"> <li>• half sine pulse shape</li> <li>• peak acceleration 1000 m/s<sup>2</sup> (100g)</li> </ul>
Vibration, random IEC 60068-2-64 (2008-04) Test Fh	<ul style="list-style-type: none"> <li>• 60 min in every three test directions</li> </ul>	<ul style="list-style-type: none"> <li>• ASD-level 5 m<sup>2</sup>/s<sup>3</sup>, 10 ... 200 Hz</li> <li>• ASD-level 1,0 m<sup>2</sup>/s<sup>3</sup>, 200 ... 500 Hz</li> <li>• total spectral acceleration 3,54 grms</li> </ul>
Vibration, sinusoidal IEC 60068-2-6 (2007-12) Test Fc	<ul style="list-style-type: none"> <li>• 90 min in each axis</li> </ul>	<ul style="list-style-type: none"> <li>• Frequency range 5...100 Hz</li> <li>• Amplitude +/- 1,6 mm, 5 ... 25 Hz</li> <li>• Constant peak acceleration 4 gn, 25...100 Hz</li> <li>• Sweep rate 1 oct/min</li> <li>• Uncertainty of measurements +/- 5,0%</li> <li>• The endurance tests (4gn) at 30 Hz</li> </ul>

Epec Oy reserves all rights for improvements without prior notice

<p>Vibration, broadband random IEC 60068-2-24 (2008-04) Test Fh</p>	<ul style="list-style-type: none"> <li>• 10 min in each test level</li> <li>• 3 mutually perpendicular axes</li> </ul>	<ul style="list-style-type: none"> <li>• ASD-level 10 m2/s3, 10 ... 200 Hz</li> <li>• ASD-level 2 m2/s3, 200 ... 500 Hz, 5,00 grms</li> <li>• ASD-level 20 m2/s3, 10 ... 200 Hz</li> <li>• ASD-level 4 m2/s3, 200 ... 500 Hz, 7,05 grms</li> <li>• ASD-level 40 m2/s3, 10 ... 200 Hz</li> <li>• ASD-level 8 m2/s3, 200 ... 500 Hz, 9,96 grms</li> <li>• ASD-level 80 m2/s3, 10 ... 200 Hz</li> <li>• ASD-level 16 m2/s3, 200 ... 500 Hz, 14,08 grms</li> <li>• ASD-level 145 m2/s3, 10 ... 200 Hz</li> <li>• ASD-level 29 m2/s3, 200 ... 500 Hz, 19,04 grms</li> </ul>
<p>Free fall, IEC 60068-2-31 (2008-05) Test Ec</p>	<ul style="list-style-type: none"> <li>• one fall on each surface and corner</li> </ul>	<ul style="list-style-type: none"> <li>• fall height 100 cm</li> </ul>

Epec Oy reserves all rights for improvements without prior notice

Corrosion			
Test	Temperature	Duration	Concentration
Salt spray test ISO 9227	+35 °C	192 h	5 % NaCl
Tightness tests for IP67			
Test	Duration and procedure	Remark	
Dust test for IP6X according to IEC 60529	<ul style="list-style-type: none"> <li>exposed to the free settling dust for 8 hours</li> <li>under pressure during the test 2 kPa</li> <li>flow rate of the air 0, 1 l/min</li> </ul>	<ul style="list-style-type: none"> <li>no deposit of dust noticed inside</li> <li>complies with the requirements stated for the protection class IP6X</li> </ul>	
Water test for IPX7 according to IEC 60529	<ul style="list-style-type: none"> <li>immersion duration 30 minutes</li> <li>immersion depth 1000 mm</li> <li>water temperature +22 °C</li> </ul>	<ul style="list-style-type: none"> <li>no ingress of water noticed inside</li> <li>complies with the requirements stated for the protection class IPX7</li> </ul>	
Water test for IPX9 according to IEC 60529	<ul style="list-style-type: none"> <li>protected against close-range high pressure, high temperature spray downs at 0°, 30°, 60°, 90. Distance 100 to 150mm</li> <li>14–16l/mm</li> <li>approx. 8000 to 10 000 kPa</li> <li>80+/-5 °C</li> <li>30s per position</li> </ul>	<ul style="list-style-type: none"> <li>no ingress of water noticed inside</li> <li>complies with the requirements stated for the protection class IPX9</li> </ul>	

Epec Oy reserves all rights for improvements without prior notice

## 8 MECHANICS AND CABLING

### 8.1 Unit Dimensions

Unit dimensions from the top:

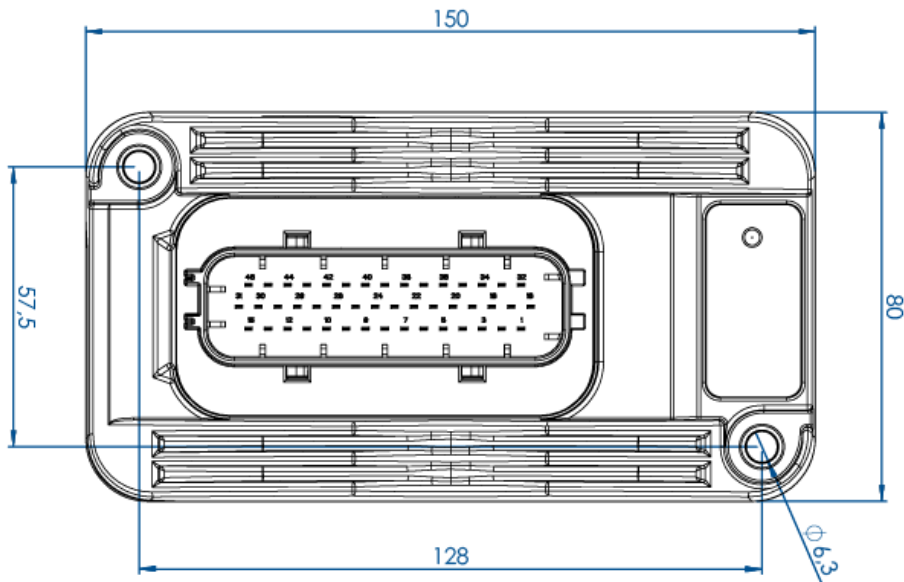

Unit dimensions from the side:

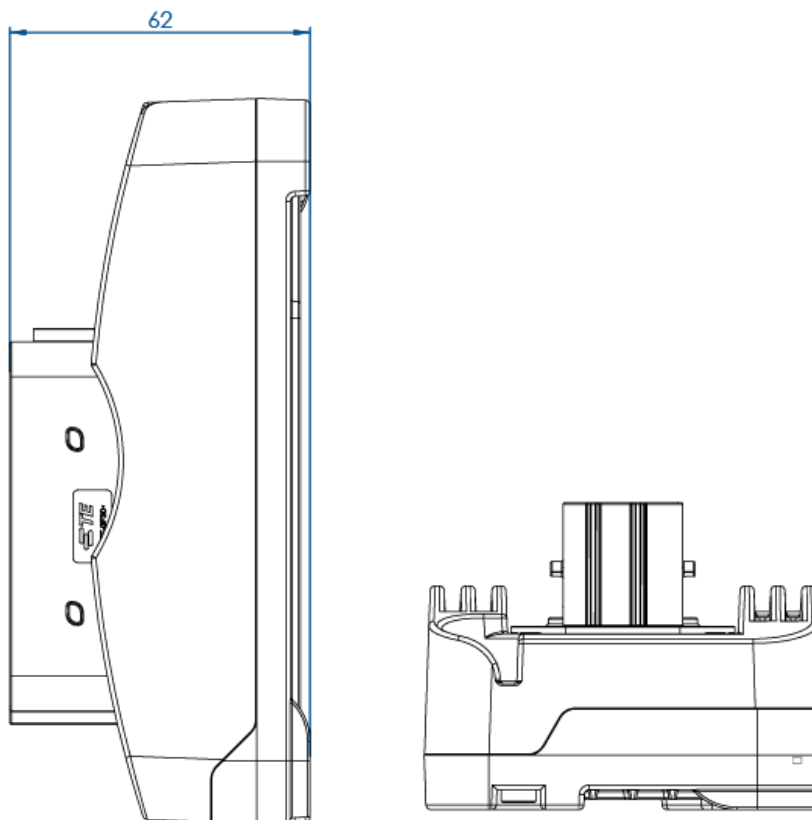

Epec Oy reserves all rights for improvements without prior notice

## 8.2 Plugging and unplugging the connectors

LEAVYSEAL connectors have silver-plated TE MCP contacts; Epec EC44 has one 46 position connector.

- 46 position module tabs are color coded (black and grey) and keyed so they will mate with only correct receptacles

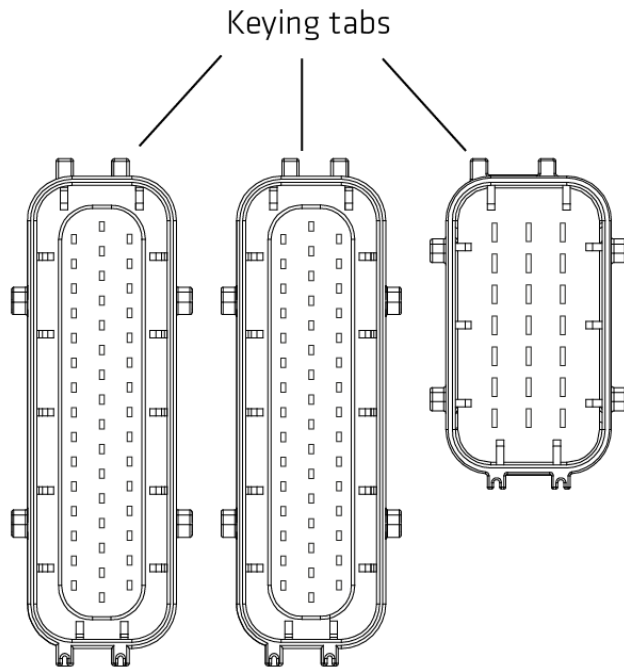

Epec Oy reserves all rights for improvements without prior notice

**8.2.1 Connector components**

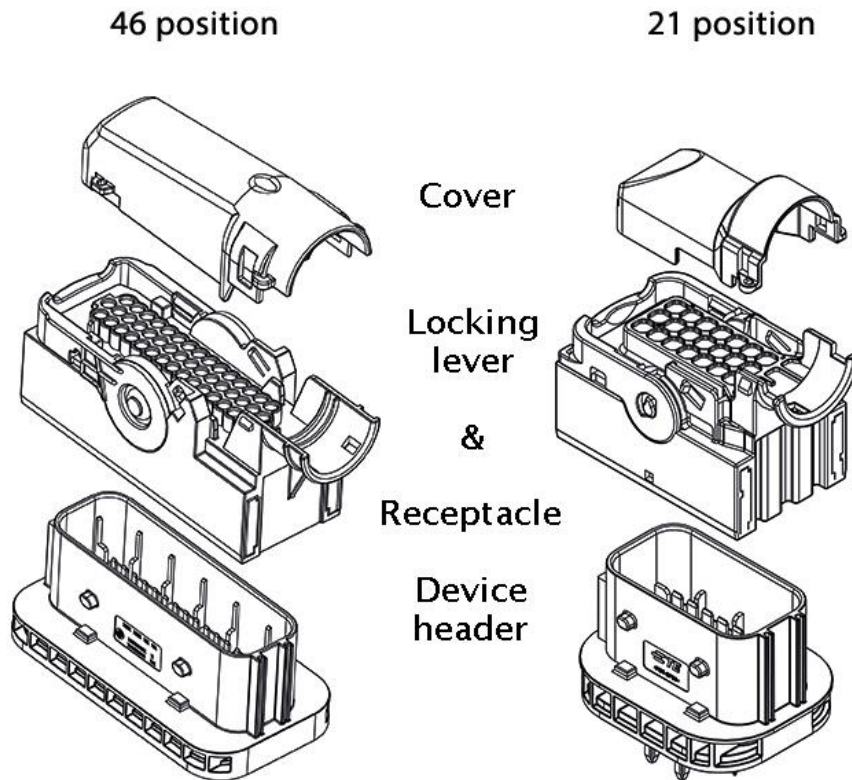

**Secondary locking device**

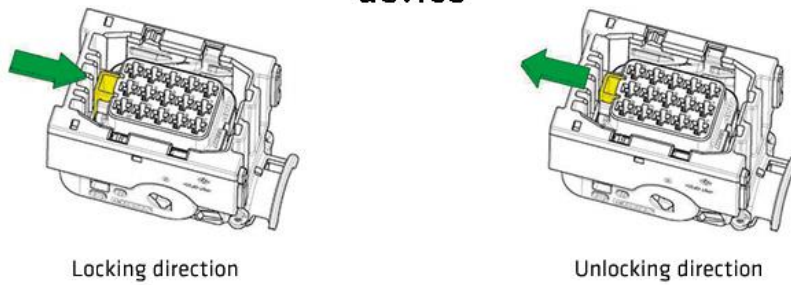

Epec Oy reserves all rights for improvements without prior notice



When inserting contacts, make sure that:

- contacts are pressed down to the bottom and that they are locked
- contacts are clean (avoid moisture or dirt inside the connector)
- unused cavities should be plugged with cavity plugs to keep the control unit connectors dry and protected
- all cables, connectors and tools are of correct type, and sufficiently high quality, and suitable for this kind of use (protection for moisture, mechanical stability, power durability, coupling resistance among other things)
- there is a sufficient margin (slack) left in the cables to prevent the torsion of the connectors
- wires are bound to the connector base knob with cable ties

## 8.2.2 Inserting contacts



**Step 1:**  
Grasp crimped contact approximately one inch behind the contact barrel.



**Step 2:**  
Verify the integrated secondary lock is in the unlocked position. Make sure the contact is in the correct orientation. Push contact straight into connector grommet until a click is felt. A slight tug will confirm that it is properly locked in place.



**Step 3:**  
Push the integrated secondary lock into the locked position with a DT-RT1 or a screwdriver.

## 8.2.3 Removing contacts



**Step 1:**  
Using a DT-RT1 or a screwdriver, unlock the integrated secondary lock.



**Step 2:**  
Using the appropriate extraction tool, insert the blades into the contact



**Step 3:**  
Pull contact wire assembly out of connector.

Epec Oy reserves all rights for improvements without prior notice

## 8.2.4 Connector component details

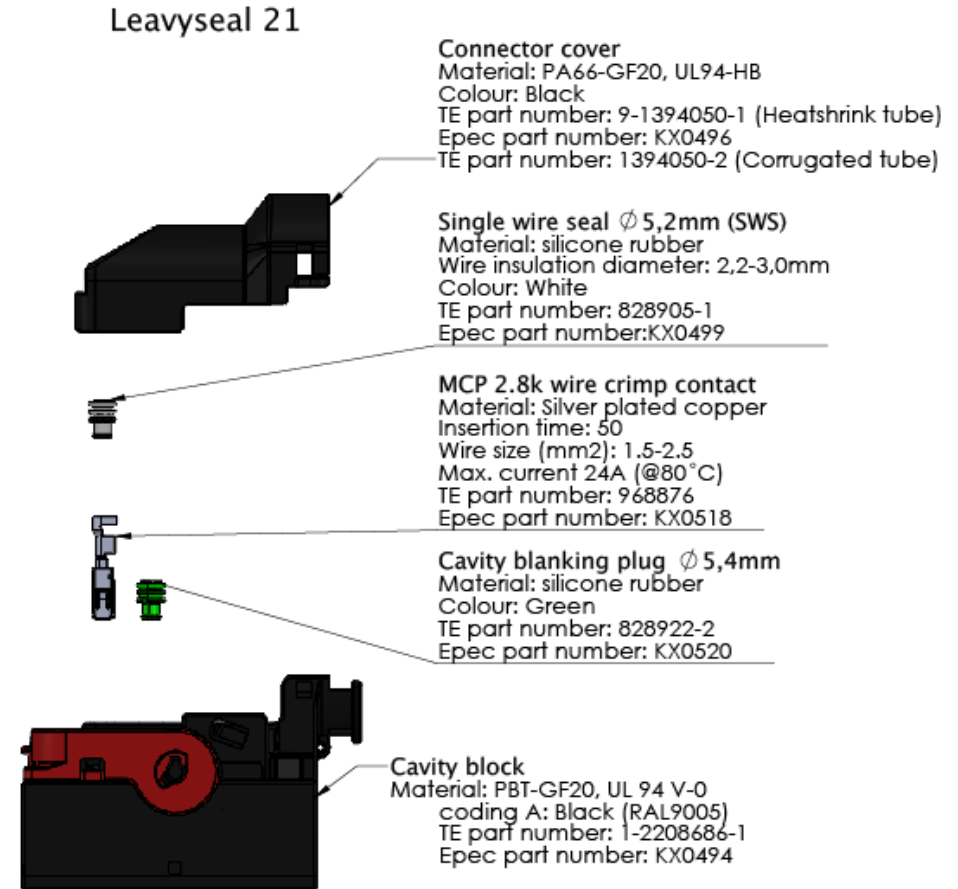
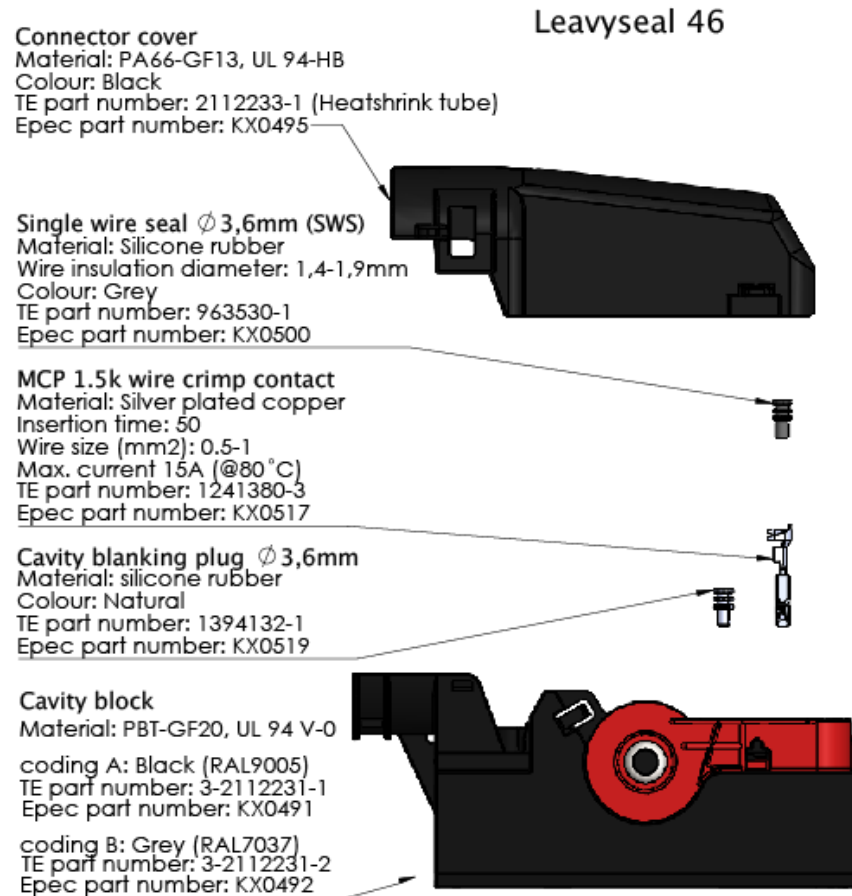

### 8.2.5 Additional documentation

Refer to documents listed below for more detailed information on connectors and cable recommendations.

Position count	Document type	TE document number
21 position	Product specification	108-18696
	Application specification	114-18376
	Crimp instruction MCP2.8	114-13295
46 position	Product specification	108-94216
	Application specification	114-94012
	Application specification	114-18455
	Crimp instruction MCP1.5	114-18386

Ordering codes for the LEAVYSEAL connectors, crimps and tools are listed in Section [Accessories and Ordering Codes](#).

Epec Oy reserves all rights for improvements without prior notice

### 8.3 Mounting and Cleaning



Control unit mounting location should be planned so that the machine's washing does not damage the unit.

A direct water jet towards the control units should be avoided, especially when using high pressure. Also, the use of any such solvent that causes damage to electronic devices should be avoided when handling the control units.



When cleaning the control unit, do not use highly alkaline / acidic substances, too hot water, or too heavy mechanical abrasion.



In moist conditions, the unit must be mounted and oriented so that the connectors are not filled with water.



If the product's assembly screws or product labels have been removed or damaged or the unit housing has been opened in any way, the warranty becomes null and void.

- Mounting recommendation: 2 x M6/M5 DIN912 Torx/Allen head bolts, no washers of any kind. Machine ground connection is required to mounting bolt threads.
- Mounting must be done on to a conductive metal base. The control unit's aluminum housing must have a galvanic connection to the machine frame.
- 2 point mounting allows mounting on a slightly uneven surface.

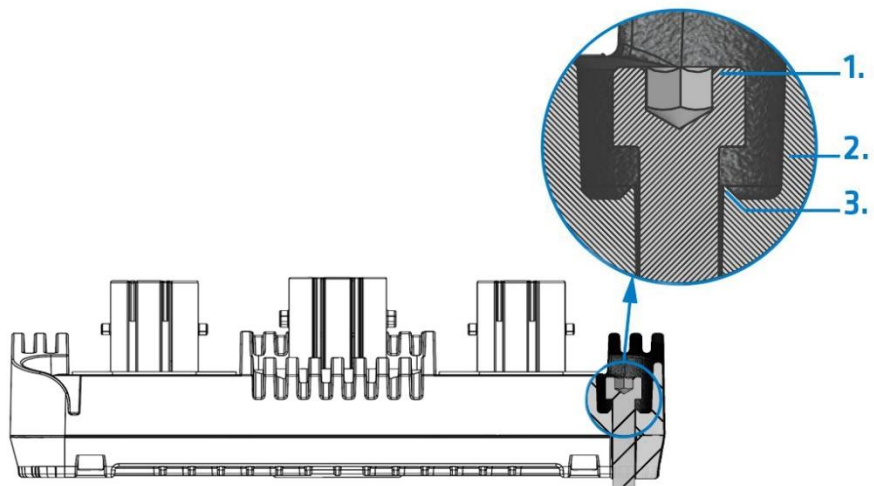

1. Unit mounting bolt
2. Unit housing
3. Mounting hole detail; paint on the sharp edge is designed to shatter when the mounting screw is tightened. This provides a galvanic connection between the mounting screw and the unit housing.

Epec Oy reserves all rights for improvements without prior notice

- The mounting position must allow water, etc. to flow away from connectors, see the figure below. The ideal orientation is shown at the bottom of the figure, where the leads go downwards
- Do not mount the unit in a position where the leads go upwards (shown at the top of the following figure)
- Do not mount the unit in a horizontal (connectors face up or down) position in wet or moist environments (shown in the middle of the following figure)
- Reserve 10 cm installation space for the connector cables

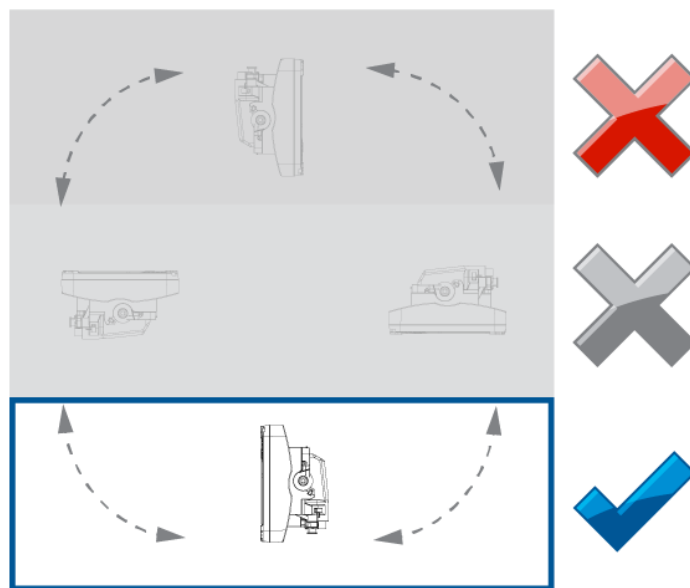

Epec Oy reserves all rights for improvements without prior notice

## 8.4 Cabling

### 8.4.1 System Topologies



Generally, cabling should be properly designed and documented to help the initial assembly and maintenance. It is highly recommended to mark each cable on both ends to avoid confusion and errors.



The cables must be run in a safe route along the machine frame. When routing cables, avoid interfering objects and pay particular attention to moving parts of the machine. It is also good to minimize the amount of the connection points of the cable harness to maximize reliability. Also, all valid safety instructions should be observed when coupling.

Control units are connected with each other using standardized CAN bus. The idea of the Epec embedded control system, is that all the control units are installed close to sensors, encoders and other equipment connected to them. This way the amount of the traffic on the CAN bus is minimized and connections can be made using short wires.

#### 8.4.1.1 Termination resistors

Generally, the bus cable is terminated at both ends with termination resistors (ISO 11898:1993).



The cable lengths presented here are approximates. Actual cable lengths also depend on the cable quality, the cable type and also on the machine environment (possible interference).

Internal Termination resistor connection in CAN 1

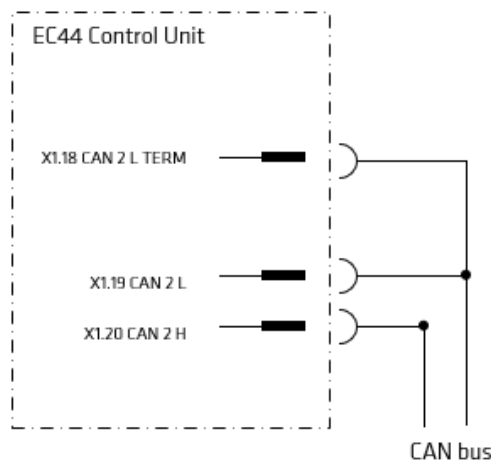

External Termination resistor connection in CAN1

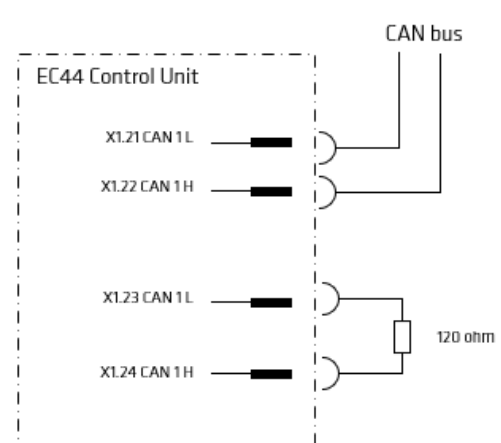

**Example1.** Termination resistor connection in CAN1

Epec Oy reserves all rights for improvements without prior notice

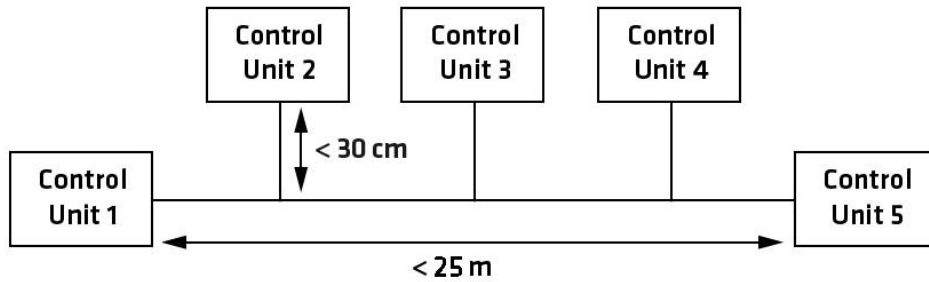

**Example 2.** Control system topology in theory with maximum bus speed (1000 kbit/s); Control Units in traditional bus arrangement. Termination resistor must be connected at control unit 1 and control unit 5. For more information about the bus speeds, refer to CiA DS-102 standard.

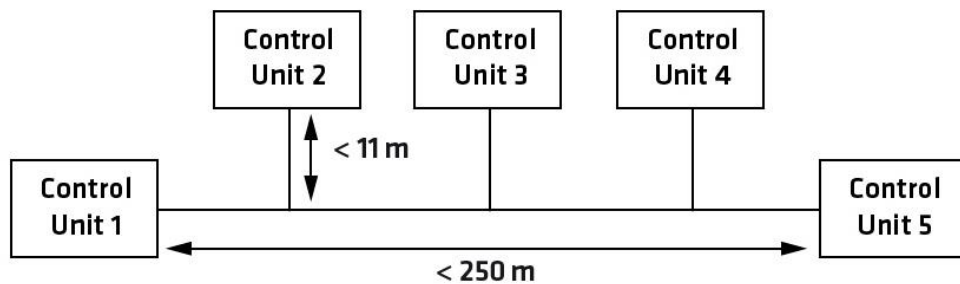

**Example 3.** Control system topology in theory with 250 kbit/s bus speed; Control Units in traditional bus arrangement. Termination resistor must be connected at control unit 1 and control unit 5. For more information about the bus speeds, refer to CiA DS-102 standard.

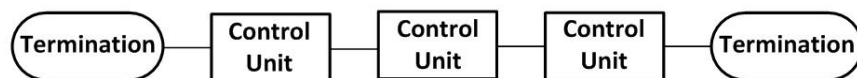

**Example 4.** The usage of the termination resistor (TR) in a conventional bus. The maximum recommended bus length is directly dependent on the bus speed. In theory, the maximum length with the maximum speed can be up to 25 meters. If the bus speed is lower, the length can be extended. The maximum length of the bus depends on the bus speed. For more information about the bus speeds, see the table below / refer to CiA DS-102 standard.

Epec Oy reserves all rights for improvements without prior notice

The following table shows some baud rates in general purpose CAN bus networks as well as the maximum bus length for a given baud rate, that CAN in Automation (CiA) international users and manufacturers group has recommended to be used. For more information, refer to CiA DS-102 standard.

**CAN bus baud rates and bus lengths according to CiA DS-102 standard**

Baudrate	Bus length
1 Mbits/s	25 m
800 kbits/s	50 m
500 kbits/s	100 m
250 kbits/s	250 m
125 kbits/s	500 m
50 kbits/s	1000 m

Epec Oy reserves all rights for improvements without prior notice

### 8.4.2 CAN Bus Cabling



The CAN bus cable is the neural backbone of the whole system and should be designed and constructed with extra care.

For information about the CAN bus lengths and baud rates, refer to section [System Topologies](#).

#### 8.4.2.1 Cable

- It is recommended to use high quality and twisted (approx. 1 round / 1 inch) CAN bus cable.
- Normal UTP (Unshielded Twisted Pairs) cable is well suited for distances under approximately 10 meters.
- In longer distances, and especially if there is possibility for electromagnetic interference, it is highly recommended to use shielded and twisted cable for CAN bus, also for shorter distances.
- To avoid electromagnetic interference (EMI), locate the bus cable as far away from high-current carrying cables as possible. Generally, the amount of the connections and connectors should be minimized to maximize security; also all connections should be done carefully.
- The shield grounding must be done only in one end of the cable

#### 8.4.2.2 Cable shield grounding

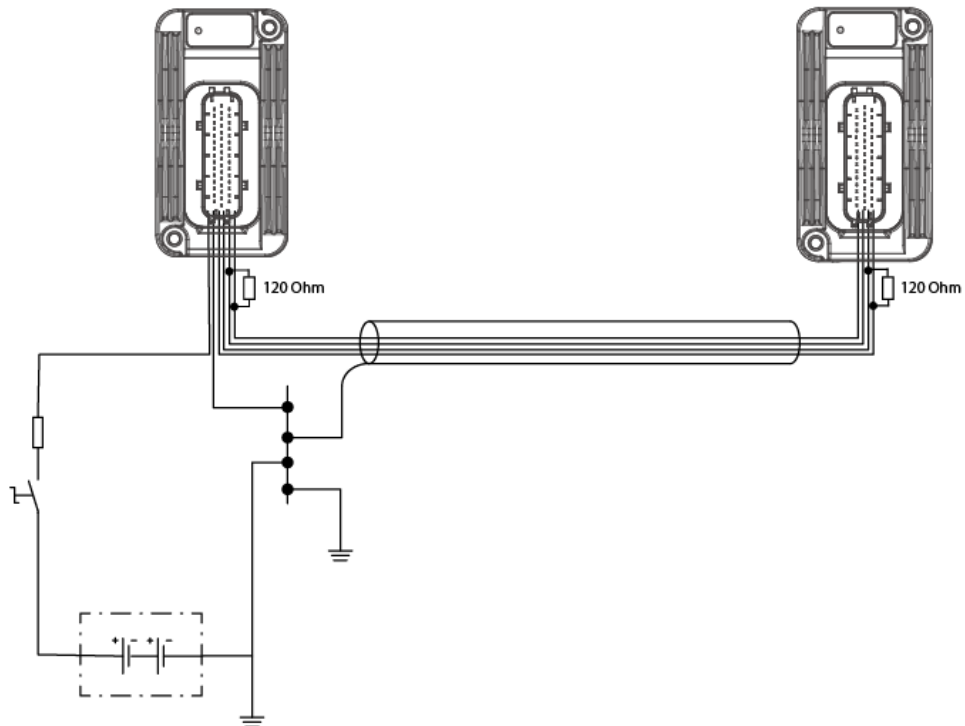

Epec Oy reserves all rights for improvements without prior notice

**8.4.2.3 CAN 1 Bus Connection**

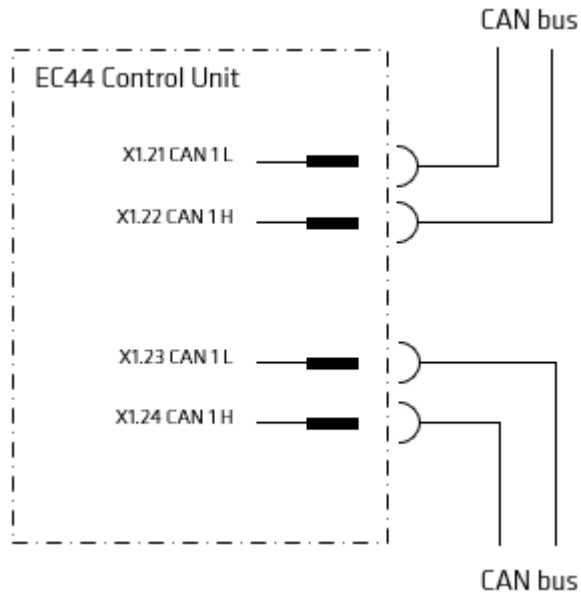

**8.4.2.4 CAN 2 Bus Connection**

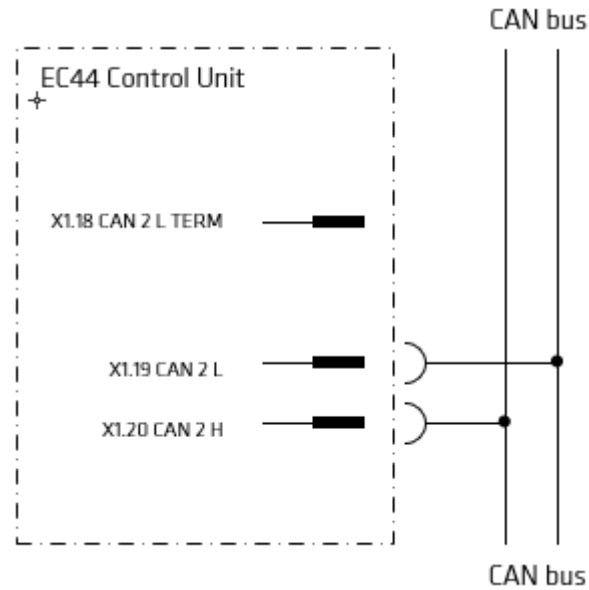

Epec Oy reserves all rights for improvements without prior notice

### 8.4.3 I/O Cabling



Closed circuit loops are always recommended when using DO or PWM. Closed circuit loop means that the current from the control unit to the sensor must return to the same control unit, see the figures below.



To ensure correct measurement, reserve separate GND pin(s) for AI pin(s) and don't use it/them for any other purposes. See the cabling example below.

- The cabling for encoders etc. is in many cases supplied together with them
- In many cases, very simple basic cable may be used, e.g. automobile R2 cable (0,5 or 1,0) by NK Cables
- Dimensions of the cable should be appropriate for MCP contacts (so that crimping is possible)
  - Refer to LEAVYSEAL table (in section [Accessories and Ordering Codes](#)) for dimensions
  - Take extra care for protecting the cables against physical wear and damage
- Only one wire can be connected to one LEAVYSEAL connector pin. However, if more than one wire has to be connected to one connector pin, it has to be connected by branch wiring
- Some voltage inputs use relatively low voltages
  - Consider using shielded cables for these encoders etc. especially for longer distances to increase safety
- Using shielded cable is recommended also in joystick connections

The following figure describes closed loop wiring:

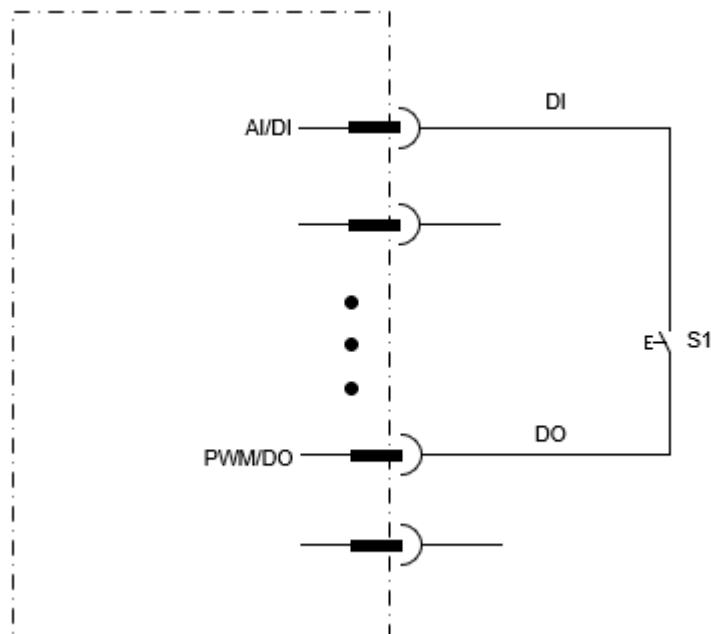

Epec Oy reserves all rights for improvements without prior notice

Do not connect the closed circuit loop as shown in the following figure:

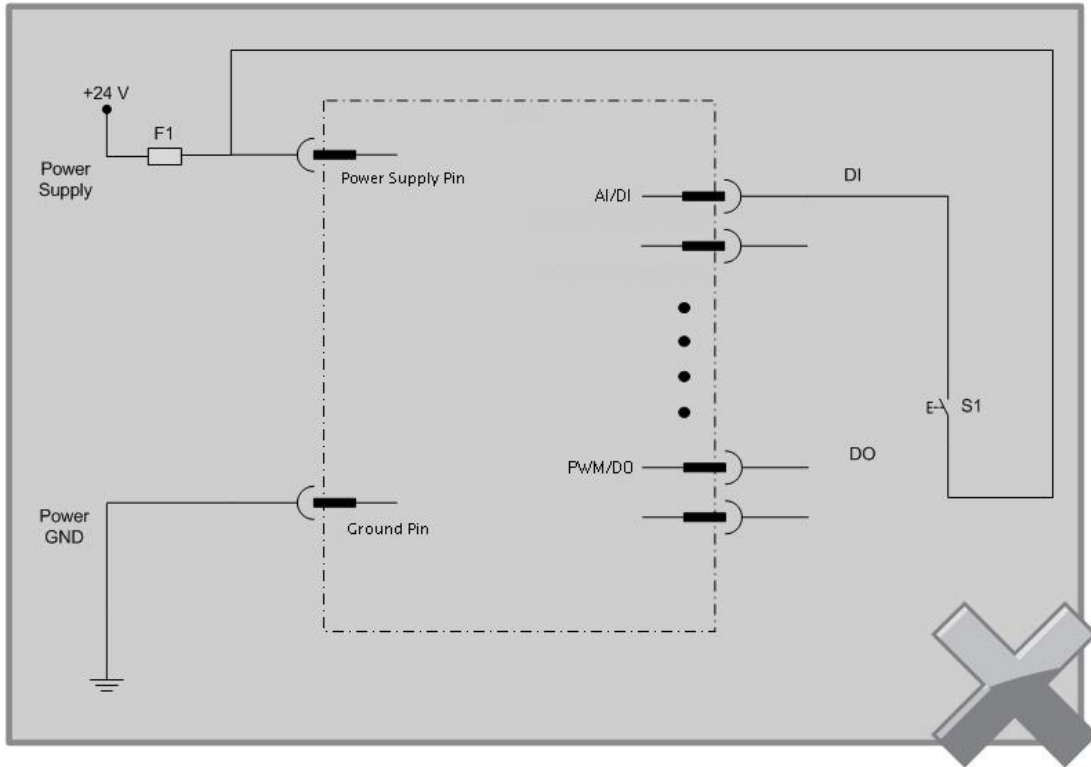

AI - GND cabling examples (use separate GND pin for AI pins):

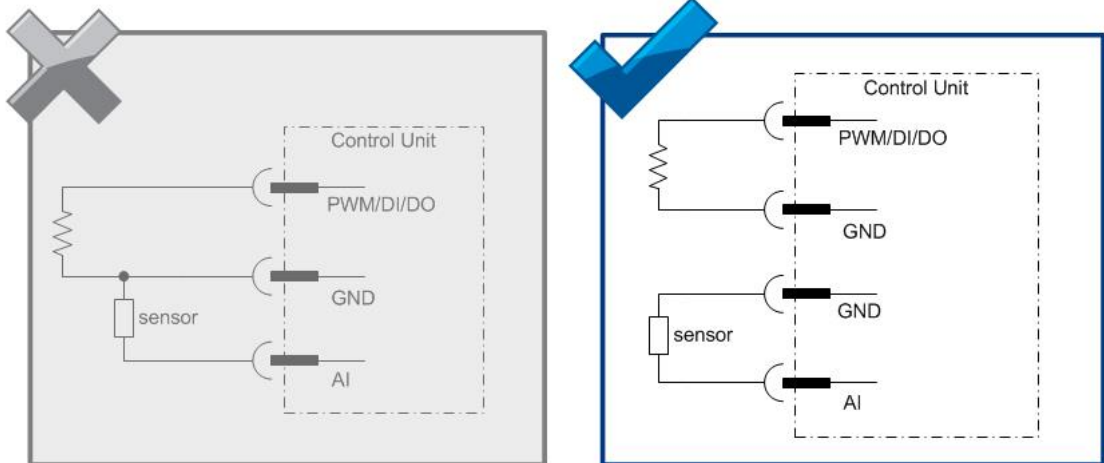

Sensors and encoders must be wired according to the closed-loop principle, i.e. the power for the sensors and encoders is supplied by the control unit they are connected to. This way, it is possible to avoid harmful potential differences, so the MOSFET driven output power switching operates properly.

Epec Oy reserves all rights for improvements without prior notice

The unit has several GND pins which allows for point to point topology to be used when wiring auxiliary devices and sensors.

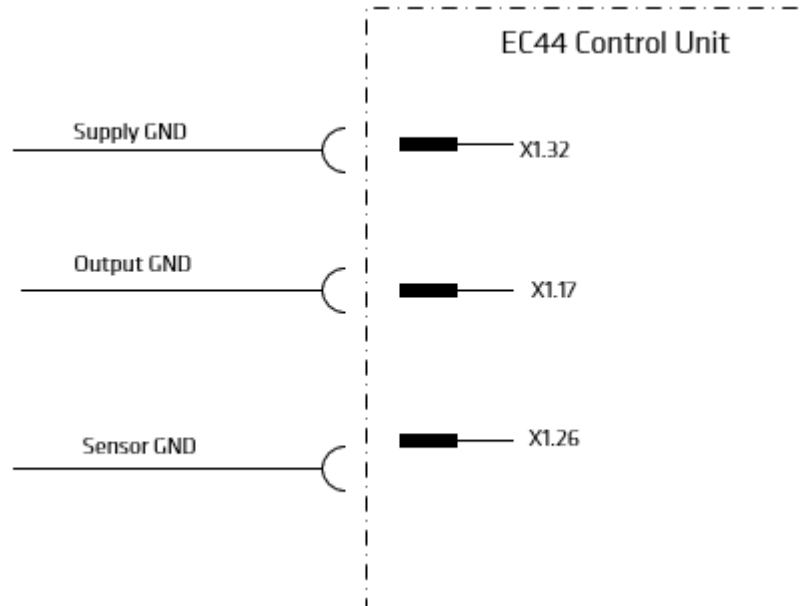

Refer to section *Power Supply* for accurate pin allocation of connectors.

Epec Oy reserves all rights for improvements without prior notice

## 8.4.4 Power Supply Cabling



The maximum continuous current per power supply pin is 15 A. However, it must be taken into consideration that the maximum overall continuous current of the controller is 20 A.



The power for sensors, encoders and other equipment should be supplied from the same unit that the equipment is connected to, to ensure the best performance of the system. No external power (or ground) connections are allowed.

- The nominal operating voltage for Epec control units is 12 and 24 VDC. The full operating range is 8,5 – 33 VDC
- See section [Power Supply](#) for accurate pin allocation of the connectors when using the Epec EC44 Control Unit
- Single point grounding should be used for power supply for all the control units

Power supply's wiring example 1 (max 15 A):

Power supply pin	X1.1
GND pins	X1.32

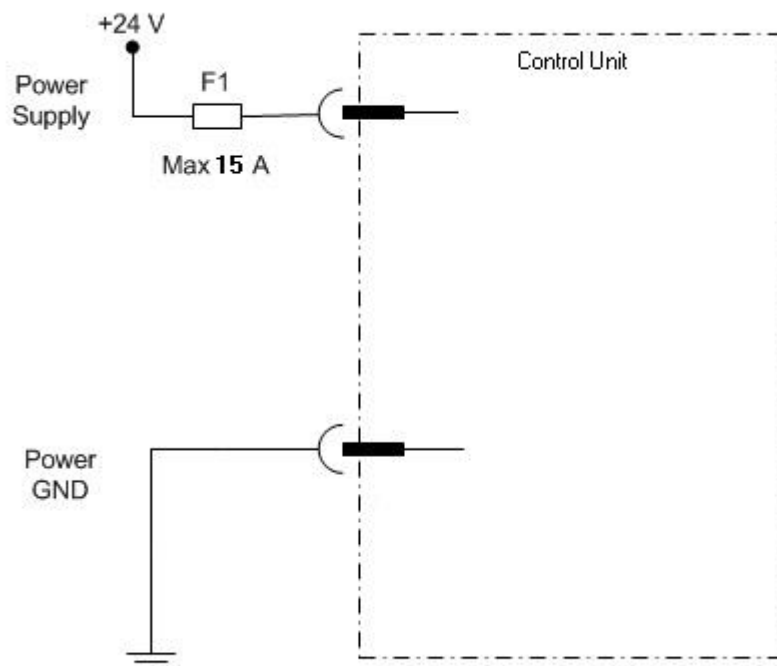

Epec Oy reserves all rights for improvements without prior notice

Power supply's wiring example 2 (max 20 A):

<b>Power supply pin</b>	X1.1, X1.16
<b>GND pins</b>	X1.32

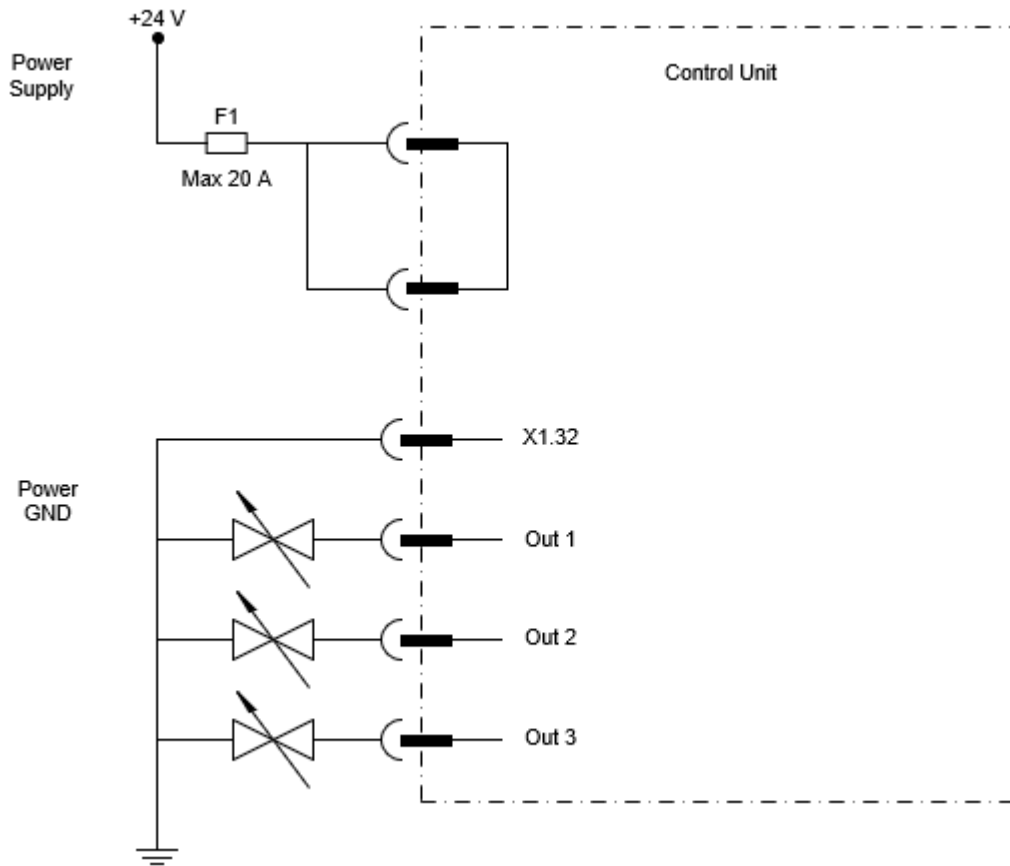

#### 8.4.4.1 Emergency Stop



In all European Community countries, the emergency stop should be implemented in accordance with standard EN ISO 13850, which complies to the EC Machinery directive 2006/42/EC. In other countries, the emergency stop should be implemented according to local standards and/or to local legislation.

Epec Oy reserves all rights for improvements without prior notice

## 8.5 Welding



Welding causes some high current flows and voltage peaks in the machine. It should be noted that the electronics of the control system may be damaged, if the welding current can get through the control unit itself.

So, when welding, it should be taken care to prevent high currents from going through the control units or through the CAN bus.

Follow carefully the following instructions.





Disconnect all the connectors from the control units before welding.





Generally, even if the control system power is disconnected, welding should be done carefully and by following appropriate safety measures. Welding grounding should be connected close to the welding point to avoid long distance high current flow through machine frame.

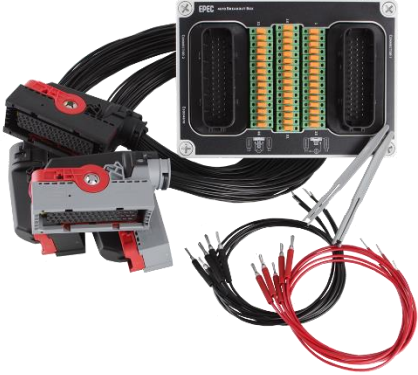

Epec Oy reserves all rights for improvements without prior notice





## 8.6 Accessories and Ordering Codes



Picture	Product name	Epec ordering code	Epec data sheet code	TE Connectivity ordering code
	<p>Epec 4610 Breakout box Includes:</p> <ul style="list-style-type: none"> <li>• 2 connector pliers</li> <li>• 5 black banana plug connector cables</li> <li>• 5 red banana plug connector cables</li> <li>• 1 LEAVYSEAL cable, 46 pin/46 pin (A code), 500mm</li> <li>• 1 LEAVYSEAL cable, 46 pin/46 pin (B code), 500mm</li> </ul>	E3004610	MAN000708	
	<p>21 pin LEAVYSEAL plug with 2m leads</p>	E30902497	MAN000709	

	<p>46 pin LEAVYSEAL plug with 2m leads (A code)</p>	<p>E30902498</p>	<p>MAN000709</p>	
	<p>46 pin LEAVYSEAL plug with 2m leads (B code)</p>	<p>E30902499</p>	<p>MAN000709</p>	
	<p>M12 CAN termination resistor</p>	<p>E30902501</p>		
	<p>LEAVYSEAL cable, 46 pin/46 pin (A code), 500mm</p>	<p>E30902504</p>	<p>MAN000709</p>	

	<p>LEAVYSEAL cable, 46 pin/ 46 pin (B code), 500mm</p>	<p>E30902505</p>	<p>MAN000709</p>	
	<p>M12 sealing cap for female connector (IP67)</p>	<p>X0058261</p>		
	<p>AMP MCP 1.5K contact (for 46 pin LEAVYSEAL) Wire size: 0.5 – 1.0 mm<sup>2</sup> Loose Piece (100 pcs)</p>	<p>KX0498</p>		<p>1241381</p>
	<p>AMP MCP 1.5K contact (for 46 pin LEAVYSEAL) Wire size: 0.5 – 1.0 mm<sup>2</sup> Strip Form (100 pcs)</p>	<p>KX0517</p>		<p>1241380</p>

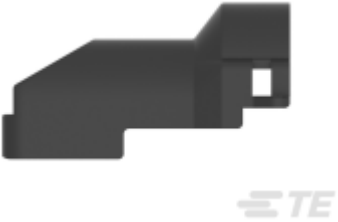

	<p>AMP MCP 2.8 contact (for 21 pin LEAVYSEAL) Wire size: 1.0 – 2.5 mm<sup>2</sup> Loose Piece (100 pcs)</p>	KX0497		968876
	<p>AMP MCP 2.8 contact (for 21 pin LEAVYSEAL) Strip Form (100 pcs)</p>	KX0518		968857
	<p>Wire Seal 1.5K (for 46 pin LEAVYSEAL) Color: Grey Insulation Diameter: 1.4 – 1.9 mm (500 pcs)</p>	KX0500		963530-1
	<p>Wire Seal 2.8 (for 21 pin LEAVYSEAL) Color: White Insulation Diameter: 2.2 – 3.0 mm (500 pcs)</p>	KX0499		828905-1



	<p>Cavity Plug (for 46 pin LEAVYSEAL) Color: Natural (500 pcs)</p>	<p>KX0519</p>		<p>1394132-1</p>
	<p>Cavity Plug (for 21 pin LEAVYSEAL) Color: Green (500 pcs)</p>	<p>KX0520</p>		<p>828922-2</p>
	<p>Connector Cover LEAVYSEAL 46 pin Color: Black (A code)</p>	<p>KX0495</p>		<p>2112233-1</p>
	<p>Cavity Block LEAVYSEAL 46 pin Color: Black (A code)</p>	<p>KX0513</p>		<p>3-2112231-1</p>

	<p>Cavity Block LEAVYSEAL 46 pin Color: Grey (B code)</p>	<p>KX0492</p>		<p>3-2112231-2</p>
	<p>Connector Cover LEAVYSEAL 21 pin Color: Black</p>	<p>KX0496</p>		<p>1394050-2</p>
	<p>Cavity Block LEAVYSEAL 21 pin Color: Black (A code)</p>	<p>KX0494</p>		<p>1-2208686-1</p>

### 8.6.1 LEAVYSEAL Tools

Tools are specific to the contact style. To create a proper crimp and achieve the highest performance specifications, contacts must be crimped with the recommended tooling.

Picture	Product name	Epec ordering code	Epec data sheet code	TE Connectivity ordering code
	Contact Extraction Tool Set	E0000040	MAN000710	1-1579008-7 (21 pin Extraction tool)  1-1579007-1 (46 pin Extraction tool)
	LEAVYSEAL Handtool frame (21 pin/ 46 pin)	E0000041	MAN000711	539635-1
	LEAVYSEAL 21 pin Die set MCP2.8	E0000042	MAN000711	539725-2

	<p>LEAVYSEAL 46 pin Die set 2 MCP1.5K (Wire insulation diameter 2,2 – 2,4 mm)</p>	<p>E0000043</p>	<p>MAN000711</p>	<p>5-1579001-3</p>
	<p>LEAVYSEAL 46 pin Die set 1 MCP1.5K (Wire insulation diameter 1,1 – 1,4 mm)</p>	<p>E0000044</p>	<p>MAN000711</p>	<p>4-1579016-0</p>

All applied cables should be properly shielded, bundled and grounded.

### 8.6.2 LEAVYSEAL Contacts

Stamped and Formed Receptacles with Single Wire Sealing System – AMP MCP.

#### TE Ordering Codes:

Size	Receptacle Part Numbers				Wire Size (mm <sup>2</sup> )	Insulation Diameter (mm)		Finish
	Strip Form	Package Quantity	Loose Piece	Package Quantity		FLK	FLR	
1.5K	1564324	4500	1564325	500	0.22 – 0.35	-	1.1 – 1.4	CuNiSi, selective silver plated (-3)
	1241380*	4500	1241381*	500	0.5 – 1.0	-	1.4 – 2.1	CuNiSi, selective silver plated (-3)
	1418884	4500	1418885	500	>1.0 – 1.5	-	2.2 – 2.4	CuNiSi, selective silver plated (-3)

2.8	968855	3500	968896	500	0.35	-	1.2 -1.4	CuNiSi, selective silver plated (1-xxx-3)
	968855	3500	968875	500	0.5 -1.0	-	1.4 - 2.1	CuNiSi, selective silver plated (1-xxx-3)
	968857*	4000	968876*	500	>1.0 -2.5	-	2.2 - 3.0	CuNiSi, selective silver plated (1-xxx-3)

\*Also available from Epec

### 8.6.3 Wire Seals

Wire seals are required for connectors without an integrated rear seal to maintain an environmental seal.

#### TE Ordering Codes:

Contact Size	Insulation Diameter (mm)	Color	Part Number	Package Quantity
1.5K	0.9 - 1.2	Green	1718705-1	10 000
	1.2 - 1.6	Red	964971-1	
		Blue	1394133-1	
	1.4 - 1.9	Grey	963530-1*	
	1.9 - 2.1	Yellow	964972-1	
	1.9 - 2.4	Orange	2112323-1	
2.8	1.2 - 2.1	Blue	828904-1	1000
			828904-2	10 000
	2.2 - 3.0	White	828905-1*	

\*Also available from Epec

#### 8.6.4 Sealing Plugs

Open cavities provide pathways for contaminants to enter the connectors. To maintain seal integrity, any unused cavity must be filled with the appropriate size sealing plug.

##### TE Ordering Codes:

Contact Size	Cavity Size (mm)	Color	Part Number	Package Quantity
1.5K	3.6	White	963531-1	10 000
		Natural	1394132-1*	
2.8	5.6	Natural	828922-1	
		Green	828922-2*	

\*Also available from Epec

## 9 GLOSSARY

---

### A

**API:** Application Programming Interface

### B

**Boot loader:** Boot loader is a software that is needed to load and run the device system. Epec boot loader cannot be updated by the customer.

### C

**CAN:** Controller Area Network

**CANopen:** Communication protocol and device profile specification for embedded systems used in automation by CAN in automation (CiA) <http://www.can-cia.org/>

**CODESYS:** Controller Development System

**CPU:** Central Processing Unit

### E

**ECC:** Error-correcting code memory

### F

**Firmware:** Firmware is the device software programmed into memory contained in the hardware. Epec firmware can be updated by the customer, Epec firmware does not include boot loader.

### G

**GFG:** Glass-Film-Glass. A touchscreen panel with a robust glass surface designed for harsh environmental conditions.

**GPS:** Global Positioning System

### H

**HMI:** Human Machine Interface

### I

**IP class:** Ingress Protection Rating, protection class. Classifies the degree of protection provided against the intrusion dust, water etc in mechanical casings and with electrical enclosures. It is published by the International Electrotechnical Commission (IEC).

### J

**J1939:** SAE J1939 protocol Vehicle bus standard used for communication and diagnostics

## L

**LCD:** Liquid-Crystal Display. A display that uses liquid crystals' light modulating properties

**LED:** Light-Emitting Diode. A semiconductor light source used for example in lamps and displays.

## M

**MB:** Megabyte

## N

**NBR:** Nitrile Rubber

## O

**OVP:** Overvoltage Protection

## P

**PCAP:** Projected Capacitive Touch

**PCB:** Printed Circuit Board

**PLC:** Programmable Logic Controller

**PLCopen:** PLCopen is a global standard for industrial control programming. IEC61131

**PWM:** Pulse-Width Modulation

## R

**RTC:** Real-Time Clock

**RTR:** Remote Transmission Request

## S

**SIM:** Subscriber Identity Module. An integrated circuit that stores securely the international mobile subscriber identity (IMSI) and the related key. They are used for identifying and authenticating subscribers on mobile telephony devices

## T

**TFT:** Thin-Film-Transistor display. A display that uses thin-film transistor technology to improve image qualities such as addressability and contrast.

## U

**USB:** Universal Serial Bus. An industry standard developed to standardize the connection of computer peripherals.

**UTC:** Coordinated Universal Time

**UVP:** Undervoltage Protection

## **W**

**WVGA:** Wide Video Graphics Array. A display resolution with the same 480 pixel height as VGA but wider, such as 800×480 (5:3).