

APLISENS

MANUFACTURE OF PRESSURE TRANSMITTERS
AND CONTROL INSTRUMENTS

USER'S MANUAL

SMART PRESSURE TRANSMITTER

type: **APCE-2000, APCE-2000G**

SMART DIFFERENTIAL PRESSURE TRANSMITTER

type:

APRE-2000, APRE-2200, APRE-2000G





SMART LEVEL PROBES

type: **APR-2000Y**

Edition D2

WARSAW JUNE 2017

Symbols used

Symbol	Description
	Warning to proceed strictly in accordance with the information contained in the documentation in order to ensure the safety and full functionality of the device.
	Information particularly useful during installation and operation of the device.
	Information particularly useful during installation and operation of a type Ex device.
	Information on disposal of used equipment.

BASIC REQUIREMENTS AND SAFE USE



- **The manufacturer will not be liable for damage resulting from incorrect installation, failure to maintain the device in a suitable technical condition, or use of the device other than for its intended purpose.**
- Installation should be carried out by qualified staff having the required authorizations to install electrical and pressure-measuring devices. The installer is responsible for performing the installation in accordance with these instructions and with the electromagnetic compatibility and safety regulations and standards applicable to the type of installation.
- The device should be configured appropriately for the purpose for which it is to be used. Incorrect configuration may cause erroneous functioning, leading to damage to the device or an accident.
- In systems with pressure transmitters there exists, in case of leakage, a danger to staff on the side where the medium is under pressure. All safety and protection requirements must be observed during installation, operation and inspections.
- If a device is not functioning correctly, disconnect it and send it for repair to the manufacturer or to a firm authorized by the manufacturer.



- In order to minimize the risk of malfunction and associated risks to staff, the device is not to be installed or used in particularly unfavourable conditions, where the following dangers occur:
- possibility of mechanical impacts, excessive shocks and vibration;
 - excessive temperature fluctuation, exposure to direct sunlight;
 - condensation of water vapour, dust, icing.



Installation of intrinsic safety versions should be performed with particular care, in accordance with the regulations and standards applicable to that type of installation.

Changes to the products manufacturing documentation may forestall a paper user updating. Current Instruction Manual is available at Producer [http. on www.aplisens.pl](http://www.aplisens.pl)

CONTENTS

I.	APPENDIX Ex.02.....	2
1.	INTRODUCTION.....	5
2.	USER MATERIALS.....	5
3.	APPLICATIONS AND MAIN FEATURES.....	5
4.	IDENTIFYING MARKS. ORDERING PROCEDURE.....	5
5.	TECHNICAL DATA.....	6
	5.1. APCE... APRE... - COMMON PARAMETERS.....	6
	5.2. APCE... - MEASUREMENT RANGES AND METROLOGICAL PARAMETERS.....	7
	5.3. APRE-2000 - MEASUREMENT RANGES AND METROLOGICAL PARAMETERS.....	8
	5.4. APRE-2200. MEASUREMENT RANGES AND METROLOGICAL PARAMETERS.....	9
	5.5. APCE-2000G. APRE-2000G. MEASUREMENT RANGES AND METROLOGICAL PARAMETERS.....	9
	5.6. APR-2000Y. MEASUREMENT RANGES AND METROLOGICAL PARAMETERS.....	10
6.	CONSTRUCTION, PRESSURE CONNECTORS, ELECTRICAL CONNECTORS.....	10
	6.1. MEASUREMENT PRINCIPLES. ELECTRONIC SYSTEM.....	10
	6.2. CONSTRUCTION.....	10
	6.3. CASING. ELECTRICAL CONNECTIONS.....	11
7.	PLACE OF INSTALLATION OF TRANSMITTERS.....	11
	7.1. GENERAL RECOMMENDATIONS.....	11
	7.2. LOW AMBIENT TEMPERATURE.....	12
	7.3. HIGH MEDIUM TEMPERATURE.....	12
	7.4. ELECTROSTATIC HAZARDS.....	12
	7.5. MECHANICAL VIBRATION. CORROSIVE MEDIA.....	12
8.	INSTALLATION AND MECHANICAL CONNECTIONS.....	12
	8.1. APCE... INSTALLATION AND CONNECTIONS.....	12
	8.2. APRE... INSTALLATION AND CONNECTIONS.....	13
	8.3. APRE-2000G. INSTALLATION AND CONNECTIONS.....	13
	8.4. APR-2000Y. INSTALLATION AND CONNECTIONS.....	13
9.	ELECTRICAL CONNECTION.....	14
	9.1. GENERAL RECOMMENDATIONS.....	14
	9.2. CONNECTIONS FOR TRANSMITTERS WITH PD-TYPE CONNECTOR.....	14
	9.3. CONNECTIONS FOR TRANSMITTERS WITH TERMINAL BOX (PZ-TYPE CONNECTOR).....	14
	9.4. PROTECTION FROM EXCESS VOLTAGE.....	14
	9.5. EARTHING.....	14
10.	SETTING AND REGULATION.....	14
	10.1. TRANSMITTER RANGE. DEFINITIONS.....	15
	10.2. CONFIGURATION AND CALIBRATION.....	15
11.	SERVICES AND SPARE PARTS.....	18
	11.1. PERIODIC SERVICE.....	18
	11.2. UNSCHEDULED INSPECTIONS.....	18
	11.3. CLEANING THE DIAPHRAGM SEAL. OVERLOADING DAMAGE.....	19
	11.4. SPARE PARTS.....	19
12.	PACKING, STORAGE AND TRANSPORT.....	19
13.	GUARANTEE.....	19
14.	ADDITIONAL INFORMATION.....	19
15.	FIGURES.....	20
	FIG. 1. APCE...APRE... TRANSMITTERS – BLOCK DIAGRAM.....	20
	FIG. 2. ELECTRICAL CONNECTIONS FOR APCE..., APRE... TRANSMITTERS.....	20
	FIG. 3. APCE-2000 TRANSMITTER WITH PD CONNECTOR.....	21
	FIG. 4. APCE-2000 TRANSMITTER WITH PZ CONNECTOR.....	21
	FIG. 5. M-TYPE CONNECTOR WITH M20X1.5 THREAD.....	22
	FIG. 6. P-TYPE CONNECTOR WITH M20X1.5 THREAD.....	22
	FIG. 7. CM30X2-TYPE CONNECTOR WITH FLUSH DIAPHRAGM WITH M30X2 THREAD.....	22
	FIG. 8. G1/2" AND G1" PROCESS CONNECTIONS.....	23
	FIG. 9. APRE-2000 DIFFERENTIAL PRESSURE TRANSMITTER WITH P-TYPE CONNECTOR.....	24
	FIG. 10. APRE-2000 DIFFERENTIAL PRESSURE TRANSMITTER WITH C TYPE VENTED COVERS.....	25
	FIG. 11. APRE-2000 DIFFERENTIAL PRESSURE TRANSMITTER WITH A SINGLE DIRECT DIAPHRAGM SEAL (EXAMPLES).....	25
	FIG. 12. APRE-2200 DIFFERENTIAL PRESSURE TRANSMITTER WITH TWO REMOTE DIAPHRAGM SEALS (EXAMPLES).....	26
	FIG. 13. APRE-2200 DIFFERENTIAL PRESSURE TRANSMITTER WITH DIRECT DIAPHRAGM SEAL AND REMOTE DIAPHRAGM SEAL.....	26
	FIG. 14. APCE-2000G PRESSURE TRANSMITTER AND APRE-2000G DIFFERENTIAL PRESSURE TRANSMITTER FOR LOW RANGES.....	27
	FIG. 15. APR-2000Y LEVEL PROBE FOR PRESSURE TANKS.....	28
	FIG. 16. ADDITIONAL EQUIPMENT FOR FITTING OF PRESSURE TRANSMITTERS.....	29
	FIG. 17. EXAMPLE: HOW TO INSTALL THE APRE-2200 TRANSMITTERS WITH REMOTE DIAPHRAGM.....	30
	FIG. 18. EXAMPLE: HOW TO INSTALL THE APRE-2000 TRANSMITTER ON A VERTICAL OR HORIZONTAL PIPE.....	30
	FIG. 19. EXAMPLE: HOW TO INSTALL THE APRE-2000 TRANSMITTER WITH A VALVE MANIFOLD TO A WALL.....	31

I. APPENDIX Ex.02



SMART PRESSURE TRANSMITTER type APCE-2000, APCE-2000G
 SMART DIFFERENTIAL PRESSURE TRANSMITTERS
 type APRE-2000, APRE-2200, APRE-2000G
 SMART LEVEL PROBES type APR-2000Y
 Ex VERSIONS

1. Introduction

1.1. This “Appendix Ex.02” applies only to the APCE-2000, APCE-2000G, APRE-2000, APRE-2200, APRE-2000G, APR-2000Y intrinsically safe (Exi) transmitters designed in accordance with ATEX Directive, provided with the rating plate as specified in section and information about Exi design in the Product Certificate.

1.2. The appendix contains supplementary information relating intrinsically safe versions of transmitters. During installation and use of Ex transmitters, reference should be made to DTR.APC.APR.02(ENG) in conjunction with “Appendix Ex.02”.

2. Use of APCE-2000, APCE-2000G, APRE-2000, APRE-2200 and APRE-2000G, APR-2000Y transmitters in hazardous areas

2.1. The transmitters are designed and manufactured in accordance with the requirements of the following standards:

EN 60079-0:2012+A11:2013, EN 60079-11:2012, EN 50303:2000.

2.2. The transmitters may operate in potentially explosive areas in accordance with the rating of the explosion protection design:



I M1 Ex ia I Ma
 II 1/2G Ex ia IIC T4/T5/T6 Ga/Gb
 II 1D Ex ia IIIC T110°C Da
 KDB 12ATEX 0077X

3. Identifying marks

Intrinsically safe transmitters are provided with a rating plate containing the information specified in paragraph 4 of DTR.APCE.APRE.02(ENG) and also at least the following:

- CE mark and number of notified body: 1453 in the case of GIG KDB;
- “Ex” mark, designation of explosion protection design, certificate number;
- Values of parameters such as. Ui, li, Pi, Ci, Li;
- Marking of electrical and process connections;
- Year of manufacture.

4. User information

Together with the ordered intrinsically safe transmitters, user receives:

- a. Product Certificate, which is also a warranty card;
- b. Declaration of Conformity;
- c. Copy of certificate – on request;
- d. User Manual numbered: DTR.APCE.APRE.02(ENG) with Appendix Ex.02

Items b, c and d are accessed at www.aplisens.pl

5. Permitted input parameters (based on data from the KDB 12ATEX 0077X and certificates and certification documentation)

- Permissible input parameters for power supply with linear output characteristic
 Ui = 30V; li = 0.1A; Pi - according to Table 1
- Permissible input parameters for power supply with trapezoidal and rectangular output characteristic
 Ui = 24V; li = 0.1A; Pi - according to Table 1

Input inductance and capacity: Ci = 11nF; Li = 0,611mH

The dependence of transmitter temperature class from temperature Ta[°C] and delivered power Pi[W] for all kinds of power supplies was introduced in Table No 1, where:

Ta – ambient temperature of mounted transmitter (for example at tank).

Table 1

Pi [W]	Ta [°C]	Temperature class
0.75	50	T6
	70	T5
	80	T4, group I
1.2	40	T6
	60	T5
	80	T4, group I



- Version of transmitter with surge arrester, marked on the plate "Version SA", does not meet the requirements of Section 10,3 of the EN 60079-11 (500Vrms). This must be taken into account when installing the equipment.
- Transmitters with a plastic rating plate and transmitters with teflon coated diaphragm seals, for group III, should be installed in a place and in a way that prevents electrostatic charging see p.7.4.

Supply examples:

- Power supply with a linear output characteristic may be e.g. a typical barrier with parameters $U_o = 28V$; $I_o = 0.093A$; $R_w = 300 \Omega$, $P_o = 0,65W$

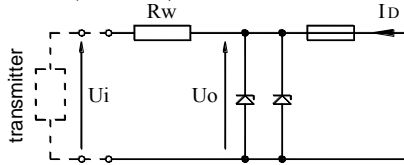

Fig.1. Power supply from a source with linear characteristic.

- Power supply with a trapezoidal output characteristic

Example of power supply from a source with trapezoidal characteristic (see Fig. 2).
 $U_Q = 48V$; $U_o = 24V$; $I_o = 0,1A$; $P_o = 1,2W$

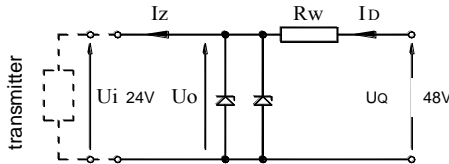

Fig. 2. Power supply from a source with trapezoidal characteristic.

If $U_o < \frac{U_Q}{2}$ then

$$U_Q = \frac{4P_i}{I_i}, \quad R_w = \frac{U_Q}{I_i}, \quad P_i = \frac{U_o(U_Q - U_o)}{R_w}$$

- Power supply with rectangular output characteristic

The supply of power from a source with a rectangular output characteristic means that the voltage of the Ex power supply remains constant until current limitation activates.

The protection level of power supplies with a rectangular output characteristic is normally "ib". Transmitters powered from such a supply are also an Ex devices with protection level "ib".

Example of practical provision of power supply for case a):

- use a stabilized power supply with $U_o = 24V$ with protection level "ib" and current limited to $I_o = 25mA$ or $50mA$, $P_o = 1,2W$.

6. How to connect Ex transmitters



Connection between transmitter and other devices in the measuring loop should be made in accordance with the requirements of intrinsically safe standards and instructions for use in hazard areas.

Non-compliance with the intrinsic safety requirements may cause the transmitter to explode and hazard to human safety and health.

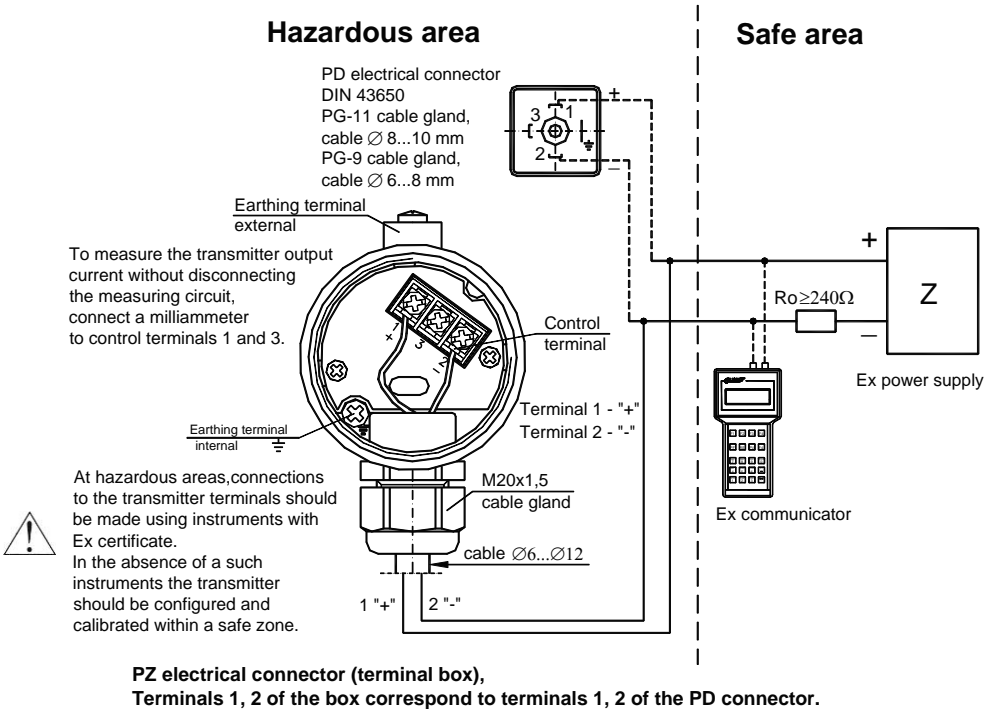

7. Basic requirements according to EN 60079-25 for type A and B leads used to connect the transmitter to the power supply and measurement circuit.

7.1. Thickness of insulation according to type of material, but not less than 0.2 mm.

7.2. Insulation strength:



- $2U_N$ but not less than 500VAC for the wire;
- 500VAC between the cable screen and the connected wires;
- 1000VAC between two groups of wires, each of which contains half the connected wires of the cable.

7.3. Multiwire cable must not carry any circuit which is not an intrinsically safe circuit.

7.4. The cable must not carry circuits with a maximum voltage exceeding 60V.

7.5. The cables should be protected from damage, for example using channels, shielding pipes, cable racks, durable fastenings etc.



Under no circumstances may the electrical system of the transmitter be repaired or otherwise handled by the user. Damage assessments and repairs may only be carried out by the manufacturer or its authorized dealer

1. INTRODUCTION

1.1. This User Manual is intended for users of **APCE-2000, APCE-2000G** smart pressure transmitters, **APRE-2000, APRE-2200, APRE-2000G** smart differential pressure transmitters and **APR-2000Y** smart level probes. The instruction contains the data and guidelines necessary to understand the functioning of the transmitters and how to operate them.

It includes essential recommendations concerning installation and use, as well as emergency procedures.

1.2. Technical data for the diaphragm seals for the **APCE-2000, APRE-2000, APRE-2200** transmitters are contained in the catalogue cards "DIAPHRAGM SEALS".

1.3. The transmitters comply with the requirements of EU directives as shown on the plate and with the relevant Declaration of Conformity.

1.4. Additional information for **APCE-2000, APCE-2000G, APRE-2000, APRE-2000G, APR-2000Y** and **APRE-2200** transmitters in Ex versions covered by the EC-type test certificate number **KDB 12ATEX 0077X** is contained in the appendix designated **DTR.APCE.APRE.02(ENG) Appendix Ex.02**.

During installation and use of the transmitters in Ex version, reference should be made to **DTR.APCE.APRE.02(ENG)** in conjunction with **Appendix Ex.02**.

1.5. The **APCE-2000, APRE-2000** transmitters are also made in a version which complies with the PED pressure directive, meet the requirements for category IV, and then carry additional markings as in p. 4.3 and 4.4.

1.6. Parameters and information given for **APCE..., APRE...** transmitters apply to the **APCE-2000, APCE-2000G, APRE-2000, APRE-2200, APRE-2200, APRE-2000G, APR-2000Y** transmitters and to the explosion-proof versions as well as all variants with different types of electrical and process connections.

2. USER MATERIALS

Transmitters are delivered in single and/or multiple packs. Every transmitter is delivered together with:

- Product Certificate, which is also a warranty card;
- Declaration of Conformity;
- Copy of certificate – on request;
- User Manual numbered: DTR.APCE.APRE.02(ENG).

Documents b, c and d are accessed at www.aplisens.pl

3. APPLICATIONS AND MAIN FEATURES

3.1. The **APCE...** pressure transmitter series are designed to measure gauge pressure, vacuum pressure and absolute pressure of gases, vapours and liquids including corrosive substances.

3.2. Differential pressure transmitters **APRE-2000** series are used to measure liquid levels in closed tanks, with static pressure up to 25MPa or 32MPa for special versions, and to measure differential pressure liquid and gases at elements such as filters, orifices, etc.

3.3. The transmitters may be fitted with a range of types of process connectors, which enables them to be used in a variety of conditions such as thick or highly reactive media, high and low temperatures, etc.

3.4. **APRE-2000G** transmitters are designed to measure absolute, gauge, and differential pressure of non-reactive gases. Typical applications are low pressure measurement include the measurement of air blasts, chimney draughts, or pressure and overpressure in combustion chambers.

The transmitters are constructed up to 35kPa or 100kPa overpressures.

3.5. **APR-2000Y** level probes are used to measure the level in closed tanks where the medium is accessed from the tank top.

3.6. **APCE..., APRE...** transmitters generate a 4...20mA output signal and a digital communication signal in a two-wire system. The use of smart electronics enables regulation of the zero point, the measurement range, damping, radical conversion characteristic and other functions using an Aplisens **KAP** communicator or a HART/RS232 converter, Aplisens "RAPORT 2" configuration software and a PC computer.

4. IDENTIFYING MARKS. ORDERING PROCEDURE

4.1. Every transmitter carries a rating plate containing at least the following information: name of manufacturer, CE mark, numbers of notified institutions and designations of certificates obtained, product type, basic range, min. set range, static pressure limit, output signal, series number, power supply voltage.

Version types and the method of specifying of the desired product by ordering are described in the current "Information Cards" and the Catalogue.

4.2. APCE..., APRE... transmitters in Ex approval have additional markings as are described in DTR.APCE.APRE.02(ENG) Appendix Ex.02.



4.3. The rating plates of **APCE-2000, APRE-2000** transmitters in versions compliant with the PED pressure directive contain the notified body number 0062 next to the CE mark, as well as the designations of certificates number H1, maximum allowable pressure PS, test pressure PT, maximum/minimum allowable temperature TS – see fig. below.

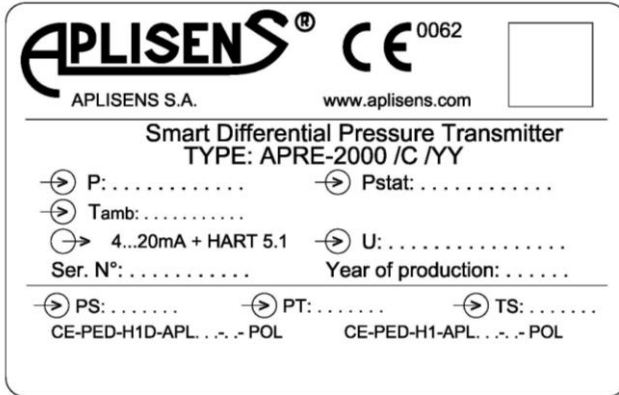

5. TECHNICAL DATA.

5.1. APCE..., APRE... - Common parameters

5.1.1. APCE..., APRE... Electrical parameters

Power supply

- normal versions 7.5 ÷ 55V DC, rated 24V DC
- intrinsic-safe versions 7,5 ÷ 30V DC"

Output signal

4÷20mA (or 20÷4mA) with HART

Communication

via HART transmission protocol and signal 4...20 mA.

For this purpose KAP-03, KAP-03Ex communicator or APLISENS converters: HART/RS232 or HART/USB/Bluetooth Converter, or other HART converter and your PC with Report 2 program (see p.10.2.4).

Resistance required for HART communication

min.250Ω

Load resistance

$$R_{Lmax}[\Omega] = \frac{U_{sup} [V] - 7.5V}{0.0225A}$$

Time for stabilization of output signal

16...230 ms - set by programming

Additional electronic damping

0...30s

Voltage for insulation testing

500 VAC or 750 VDC, see 9.4.

Excess voltage protection

see 9.4.

5.1.2. APCE..., APRE.... Permitted environmental conditions

Operating temperature range

-40°C ÷ 85°C (ambient temperature) – for APCE...

-25°C ÷ 85°C (ambient temperature) – for APRE...

-30°C ÷ 85°C (ambient temperature) – for APRE-2000G



Operating temperature range for intrinsic-safe versions in accordance with Appendix Ex.02.

Medium temperature range

-40°C ÷ 120°C – direct measurement – for APCE...

-25°C ÷ 120°C – direct measurement – for APRE...,

over 120°C measurement with the use of a transmission tube or diaphragm seal.

Medium temperature range

-40°C ÷ 100°C – for APCE...

for transmitters compliant with PED directive

-25°C ÷ 100°C – for APRE...

Thermal compensation range	-25°C ÷ 80°C -40°C ÷ 80°C for special version APCE... -10°C ÷ 70°C for APRE-2000G
Relative humidity	0% ÷ 98%
Vibration during operation	max 4g
Exposure to direct sunlight	not recommended causing strong transmitter warming

5.1.3. APCE..., APRE... Construction materials

Diaphragm seal for APCE...	steel 1.4404/1.4435 (316L) or Hastelloy C276
Diaphragm seal for APRE...	steel 1.4404/1.4435 (316L) (PED) or Hastelloy C276
Sensing module	steel 1.4404 (316L)
Casing for electronic parts	steel 1.4301 (304)
Connectors for APCE...	steel 1.4404 (316L) or Hastelloy C276 only for P, GP, CM30x2
C-type vented covers and connectors for APRE...	steel 1.4404 (316L)
Liquid filling of the interior the sensing module	Silicone oil, chemically inactive liquid for measurement of oxygen.

5.1.4. APCE..., APRE... Ingress Protection Rating of Case according to EN 60529

IP65 - PD type connector; IP66 - PZ type connector.

5.2. APCE...- Measurement ranges and metrological parameters.

5.2.1. APCE..., Measurement ranges

N°	Nominal measuring range (FSO*)	Minimum set range	Rangeability	Overpressure limit (without hysteresis)***
1.	0...1000bar (0...100MPa)	10bar (1MPa)	100:1	1200bar (120MPa)
2.	0...300bar (0...30MPa)	3bar (300kPa)	100:1	450bar (45MPa)
3.	0...160bar (0...16MPa)	1.6bar (160kPa)	100:1	450bar (45MPa)
4.	0...70bar (0...7MPa)	0.7bar (70kPa)	100:1	140bar (14MPa)
5.	0...25bar (0...2.5MPa)	0.25bar (25kPa)	100:1	50bar (5MPa)
6.	0...7bar (0...0.7MPa)	0.07bar (7kPa)	100:1	14bar (1.4MPa)
7.	-1...7bar (-100...700kPa)	0.07bar (7kPa)	114:1	14bar (1.4MPa)
8.	-1...1.5bar (-100...150kPa)	0.12bar (12kPa)	20:1	4bar (400kPa)
9.	0...2bar (0...200kPa)	100mbar (10kPa)	20:1	4bar (400kPa)
10.	0...1bar (0...100kPa)	50mbar (5kPa)	20:1	2bar (200kPa)
11.	-0.5...0.5bar (-50...50kPa)	50mbar (5kPa)	20:1	2bar (200kPa)
12.	0...0.25bar (0...25kPa)	25mbar (2.5kPa)	10:1	1bar (100kPa)
13.	-100...100mbar (-10...10kPa)	20mbar (2kPa)	10:1	1bar (100kPa)
14.	-15...70mbar* (-1.5...7kPa)	5mbar (0.5kPa)	17:1	0.5bar (50kPa)
15.	-25...25mbar** (-2.5...2.5kPa)	2mbar (0.2kPa)	25:1	1bar (100kPa)
16.	-7...7mbar** (-7...7kPa)	1mbar (0.1kPa)	14:1	1bar (100kPa)
17.	0...1,3bar abs (0...130kPa abs)	100mbar abs (10kPa abs)	13:1	2bar (200kPa)
18.	0...7bar abs (0...7MPa abs)	100mbar abs (10kPa abs)	70:1	14bar (1.4MPa)
19.	0...25bar abs (0...2.5MPa abs)	0.25bar abs (25kPa abs)	100:1	50bar (5MPa)
20.	0...70bar abs (0...7MPa abs)	0.7bar abs (70kPa abs)	100:1	140bar (14MPa)

* - only for transmitters without diaphragm seal;

** - only for transmitters in Double Sensor version;

*** - overpressure limit can be different for version according to PED.

5.2.2. APCE..., Metrological parameters

Accuracy	± 0.1% of calibrated range
Long term stability (for the basic range)	≤ accuracy / 3 years
HS version	≤ accuracy / 6 years
Error due to supply voltage changes	± 0.002% (FSO*) / 1V
Thermal error	± 0.08% (FSO) / 10°C (± 0.1% FSO / 10°C for range n°13, 14, 16).
Thermal error for the whole thermal compensation range	± 0.25% (FSO) (± 0.4% FSO / 10°C for range n°13, 14, 16). *) Full Scale Output.

5.2.3. Metrological Parameters APCE-2000 for PED version

APCE-2000 transmitters, in the PED pressure directive versions, are produced with a measurement range in the interval from -1 bar to 400bar gage, or from 0 to 400 bar absolute, with the overpressure up to PS=440bar.

i APCE-2000 transmitters with the S-Mazut seal pressure connection, assembled with the PED version can be produced within the range -1bar to 100 bar gage, or within the 0 - 100bar absolute, and the overpressure up to PS=110bar.

Other parameters are as given in p.5.2.2 except that the ambient temperature error is 7mbar/10°C.

The value of the pressure measurement range and related overpressure are given on rating plate and at Product Certificate.

5.2.4. APCE..., Pressure Connectors

- M-type connector with M20x1.5 thread – see figure 5a – available for PED version;
- P-type connector with M20x1.5 thread – see figure 6a – available for PED version;
- CM30x2-type connector with flush diaphragm – see figure 7a;
- G1/2 -type connector with G1/2" thread – see figure 8a – available for PED version;
- GP -type connector with G1/2" thread – available for PED version;
- CG1-type connector with G1" thread and flush diaphragm – see figure 8e – available for PED version;
- RM – type connector with M20x1.5 thread with radiator;
- RP – type connector with M20x1.5 thread with hole Φ 12 with radiator;
- G1/4 – type connector with G1/4" thread with hole Φ 4 – available for PED version;
- 1/2NPT M type connector with 1/2NPT tread, available for PED version;
- R1/2-type connector with R1/2 tread, available for PED version;
- CG1/2-type connector with G1/2 tread and flush diaphragm, available for PED version;
- Other connection types by arrangement.

5.3. APRE-2000 - Measurement ranges and metrological parameters

5.3.1. APRE-2000, Measurement ranges

N°	Nominal measuring range (FSO)	Minimum set range	Rangeability	Overpressure limit	Static pressure limit	
1	0...70bar (0...7MPa)	7bar (700kPa)	10:1	(70bar for P-type connector)		
2	0...16bar* (0...1,6MPa)	1,6bar (160kPa)	10:1			
3	0...2,5bar (0...250kPa)	0,2bar (20kPa)	12,5:1	C-type: 250 / 320 / 420 bar P-type: 40 bar (PS=275 bar for version compliant with the PED pressure directive)		
4	0...1bar* (0...100kPa)	50mbar (5kPa)	20:1			
5	0...0,25bar* (0...25kPa)	10mbar (1kPa)	25:1			
6	-0,5...0,5bar* (-50...50kPa)	0,1bar (10kPa)	10:1			
7	-100...100mbar* (-10...10kPa)	10mbar (1kPa)	20:1			
8	-5...70mbar* (-0,5...7kPa)	4mbar (0,4kPa)	18:1			
9	-25...25mbar* (-2,5...2,5kPa)	2mbar (0,2kPa)	25:1			
10	-7...7mbar** (-700...700Pa)	1mbar (0,1kPa)	14:1			C-type: 20bar ; P-type: 40bar
						20bar

* - available also in HS version;
** - available only in HS version.

5.3.2. APRE-2000, Metrological parameters

Accuracy	$\pm 0.1\%$ for the basic range
Long term stability (for the basic range)	\leq accuracy / 3 years $\leq 2 \times$ accuracy / 5 years
	HS version \leq accuracy / 6 years
Error due to supply voltage changes	$\pm 0.002\%$ (FSO) / 1V
Thermal error	$\pm 0.08\%$ (FSO) / 10°C
Thermal error for the whole thermal compensation range	$\pm 0.3\%$ (FSO)
Zero shift error for static pressure*	$\pm 0.08\%$ (FSO) / 10 bar (for range n° 8) $\pm 0.01\%$ (FSO) / 10 bar (for range n° 3, 4, 5, 6, 7, 9) $\pm 0.06\%$ (FSO) / 10 bar (for range n° 1, 2) $\pm 0.02\%$ (FSO) / 10 bar (for range n° 10) $\pm 0.01\%$ (FSO) / 10 bar (for range n° 2, 8) in HS version
Cut-off on radical characteristic curve	of up to 10%

* Error can be eliminated by the transmitter zeroing in static pressure conditions with zero differential pressure.

5.3.3. APRE-2000, Pressure Connectors

APRE-2000 without diaphragm seals - P-type connector with M20x1.5 thread – see fig.9 or C-type connector to mount together with a valve manifold see fig.10.

APRE-2000 with single direct diaphragm seal – as in the example (figure 11) or with other diaphragm seals in accordance with catalogue cards "DIAPHRAGM SEALS".

5.4. APRE-2200, Measurement ranges and metrological parameters

5.4.1. APRE-2200, Measurement ranges

Nominal range (FSO)	Minimum set range	Vertical spacing of diaphragm seals.	Maximum configurable range dependent on the actual vertical spacing of diaphragm seals. (m)	Static pressure limit
-160...160 mbar	0.1 mH ₂ O	≤ 1.7m	[1,6+(vertical spacing of sealsx94)]mH ₂ O	40bar
-0.5...0.5 bar	0.5 mH ₂ O	≤ 6m	[5+(vertical spacing of sealsx1.04)]mH ₂ O	40bar
-1.6...2 bar	1.5 mH ₂ O	≤ 15m	[20+(vertical spacing of sealsx1.04)]mH ₂ O	40bar
-1.6...16 bar	1bar	≤ 15m	16bar	40bar

5.4.2. APRE-2200, Metrological parameters

Accuracy	± 0.1% (FSO)
Thermal error	± 0.08 % (FSO) / 10°C
Thermal error for the whole thermal compensation range	± 0.3 % (FSO)
Zero shift error for static pressure	± 0.08 % (FSO) / 1MPa
Error related to U supply changes.	± 0.002 % (FSO) / 1V
Additional errors due to effects of sealing	see catalogue cards "DIAPHRAGM SEALS".

i The maximum vertical diaphragm seal spacing shown in the table applies to level measurement, ensuring that it is possible to set the zero point of the transmitter when the tank is empty. For measurements of density or phase boundaries (in the sugar and chemical industries and in refineries) the vertical spacing of the diaphragm seals can be larger.

5.4.3. APRE-2200. Permitted Environmental Conditions.

Vibration during operation: vibration of the transmitter is not recommended, but vibration is permissible at the place where the seals are installed. Permitted temperature and corrosive properties of medium are dependent on the diaphragm seal type (see catalogue cards "DIAPHRAGM SEALS").

Other parameters as given in 5.1.4.

5.4.4. APRE-2200. Pressure Connectors

See fig. 12, 13 and for other remote diaphragm seals - see catalogue cards "DIAPHRAGM SEALS".

5.5. APCE-2000G, APRE-2000G, Measurement ranges and metrological parameters.

5.5.1 APCE-2000G, APRE-2000G. Measurement ranges

N°	Nominal range (FSO)	Minimum set range	Overpressure limit	Static pressure limit
1	0...25mbar (0...2500Pa)	1mbar (100Pa)	1bar	350mbar
2	-2.5...2.5mbar (-250...250Pa)	0,2mbar (20Pa)	350mbar	350mbar
3	-7...7mbar (-700...700Pa)	1mbar (100Pa)	350mbar	350mbar
4	-25...25mbar (-2500...2500Pa)	5mbar (500Pa)	1bar	1bar
5	-100...100mbar (-10...10Pa)	20mbar (2kPa)	1bar	1bar

5.5.2. APCE-2000G, APRE-2000G. Metrological parameters

Nominal range	0...25mbar	-2.5...2.5mbar	-7...7mbar	-25...25mbar	-100...100mbar
Accuracy	≤ ± 0.075 %	≤ ± 0.25 %	≤ ± 0.1 %	≤ ± 0.1 %	≤ ± 0.075 %
Thermal error	± 0.1 % (FSO) / 10°C, max ± 0.4 % (FSO) for the whole thermal compensation range				
Thermal compensation range	-10 ... 70°C				

5.5.3. APCE–2000G, APRE–2000G. Construction Materials

Adapter M20x1.5/Ø6x1	brass
Valve manifold	Stainless steel 1.4404 (316L)
Adapter for valve manifold	Stainless steel 1.4404 (316L)
Connector ¼ NPT	brass, steel 1.4404 (316L) or St3S+ (galvanized)

(Other materials as given in 5.1.3 for APRE..., APRE-2000, APRE-2200).

5.5.4. APCE–2000G, APRE–2000G. Pressure Connectors

- The terminals fit ø 6x1 plastic tubes;
- Adapter to a valve manifold or ¼ NPT connector - (see. 8.3. and fig.14).

5.6. APR–2000Y. Measurement ranges and metrological parameters.

5.6.1. APR–2000Y. Measurement ranges

N°	1	2
Basic range	0...6000 mmH ₂ O	0...1600 mmH ₂ O
Minimum set range	600 mmH ₂ O	160 mmH ₂ O
Static pressure limit	40 bar	

5.6.2. APR–2000Y. Metrological parameters

N°	1	2
Accuracy for nominal measuring range	± 0.16 %	± 0.2 %
Accuracy for minimum range	± 0.5 %	± 0.6 %
Error due to ambient temperature changes	0.4 % for temperatures: -25...+80°C	
Zero shift error for static pressure *	0.08 % / 10 bar	0.1 % / 10 bar

* This error can be eliminated by zeroing the transmitter in static pressure conditions with zero differential pressure.

Range of medium densities:

- up to 1,1 g/cm³ – (standard version);
- over 1,1 g/cm³ – (special version by arrangement with APLISENS).

6. CONSTRUCTION, PRESSURE CONNECTORS, ELECTRICAL CONNECTORS

6.1. Measurement Principles, Electronic System

APCE... electronic pressure transmitters and APRE... electronic differential pressure transmitters work by converting changes in the resistance of a piezoresistance bridge, which are proportional to the pressure difference being measured, into a standard current signal.

The active sensing element is a silicon diaphragm with four (bridge) piezoresistors, separated from the medium by a sealing diaphragm and manometric fluid.

The electronic system digitally processes the measurement signal and generates output signals: an analogue: 4÷20 mA signal, and a digital HART communication signal.

A transmitter electrical block diagram is presented in Figure 1. On the input circuit two analogue signals are formed, reflecting the measured pressure and the sensing module temperature. These signals are digitized and imputed to a microprocessor. Using data input during the production process adjusts for thermal errors and carries out linearization.

After processing, the digital signal is converted into an analogue 4÷20mA current signal, with a superimposed digital communication signal.

For communication with the transmitter via analog signal line the Aplisens KAP communicator, or a PC computer meeting the requirements given in 10.2.4, is used.

The transmitter's input point is fitted with a noise filter and elements protecting against excess voltage.

Plasma surge arrester is installed in the special Exi version on request. The transmitter then has got, on rating plate, marking "Version SA".

6.2. Construction

The main components of the smart pressure transmitter is the sensing module, in which the pressure signal is converted into an electrical signal, and the electronic system, which converts the signal from the sensing module into a 4...20mA output analog signal and produces a digital HART signal.

6.2.1. To the **APCE...** sensing module transmitters may be installed the pressure connectors as in figures 5a, 6a, 7a, 8 or other. They are equipped with a diaphragm separating the internal part of the head from the medium.

6.2.2. In the **APRE-2000** transmitters, the sensing module has two kind of process connectors: P-type connectors (figure 9), or C-type with covers connecting for installation on a valve manifold (figure 10).

6.2.3. The **APRE-2000** transmitters may be fitted with a single direct diaphragm seal, mounted on the “+” pressure input of the sensing module, while the “-” input is a ¼NPT socket (figure 11).

The **APRE-2200** transmitter is fitted with two diaphragm seals and can be produced in two versions:

- with one direct diaphragm seal and one remote diaphragm seal (figure 13);
- with two remote diaphragm seals (figure 12).

The diaphragm seal transmits the pressure obtained from the medium. The pressure is transmitted via a manometric fluid which fills the space between the diaphragm of the seal and the diaphragm of the sensing module. In the case of remote diaphragm seals, pressure is transmitted via a capillary linking the transmitter's sensing module to the diaphragm seal.

The construction of the seals depends on the medium properties and operating conditions for which they are intended.

Technical data relating to the diaphragm seals' dimensions and operating conditions can be found in catalogue cards “DIAPHRAGM SEALS”.

6.2.4. The **APRE-2000G** are designed to the low pressures measurement of non-aggressive gases, with a permitted overpressure of 35kPa or 100kPa. The basic (economy) version of this transmitter has terminals fitting $\varnothing 6 \times 1$ elastic tubes, while the industrial version has adapters as shown in figure 14.

6.3. Casing, Electrical Connections

APCE..., **APRE...** transmitters are cased in an $\varnothing 51$ pipe with a PD (DIN 43650) or PZ type connector.

6.3.1. The **PD** type connector (figure 3) is located on the top of the casing ($\varnothing 51$ pipe) and sealed with a rubber washer.

6.3.2. Transmitters with a **PZ** type connector (figure 4) have a terminal box connected permanently to the casing. The box is closed with a lid and has an external and internal earthing terminal. Mounted on the inside a terminal block is equipped with additional control terminals, galvanically connected to terminals 1, 2 and 3.

7. PLACE OF INSTALLATION OF TRANSMITTERS

7.1. General recommendations

7.1.1. The pressure transmitters and differential pressure transmitter can be installed both indoors and outdoors. It is recommended that transmitters installed outdoor should be placed in a box or under cover. There is no need for a cover in the case of transmitters with **PZ** type electrical connector.

7.1.2. The place of installation should be chosen in such a way as to allow access to the device and to protect it from mechanical damage. In planning the transmitter installation and the pulse lines configuration, should be paid attention to the following requirements:

- The impulse lines should be as short as possible, with a sufficiently large cross-section, and free of sharp bends, in order to prevent blockages.
- Where the medium is a gas, the transmitters should be installed above the measuring point, so that condensation flows down towards the site of the pressure measurement; where the medium is a liquid or where a protective liquid is used, the transmitters should be installed below the place where the pressure measurement is taken.
- The impulse lines should be inclined at a gradient of at least 10cm/m.
- The levels of filling liquid in the impulse lines should be equal or kept constant difference.
- The configuration of the impulse lines and the valve connection system should be chosen with regard to the measurement conditions and to requirements such as the need to reset the transmitters in position and the need for access to the impulse lines during water or gas removal and flushing.



7.1.3. **Where there is a risk of heavy objects hitting the instrument (resulting, in extreme cases, in a part of the system with transducers being torn off and medium leakage), appropriate means of protection should be applied for safety reasons and to avoid the possibility of sparking or other, more appropriate location should be selected for the transmitter.**



7.1.4. Attention should also be paid to possible installation faults which may lead to measurement errors, such as connections which are not tight, sediment blockage in lines which are too narrow, gas bubbles in a liquid line or liquid column in a gas line etc.

7.2. Low Ambient Temperature



When the solidification point of the liquid whose pressure is being measured is greater than the ambient temperature, steps should be taken to protect the measurement apparatus from freezing effects.

This is particularly important in the case open-air installations.

Protection is obtained by filling the impulse lines with a mixture of ethylene glycol and water, or another liquid whose solidification point does not exceed the ambient temperature. Thermal insulation can protect the casing of the transmitter and lines only from brief exposure to low temperatures. Where the temperature is very low, the transmitter and impulse lines are should be heated.

7.3. High Medium Temperature

The **APCE...**, **APRE...** transmitters may be used to measure media with temperatures of up to 120°C.

To protect the sensing module from temperatures in excess of 120°C, suitably long impulse lines are used to disperse the heat and to lower the temperature of the module.

Where it is not possible to use impulse lines of the required length, **APCE...**, **APRE...** transmitters with remote diaphragm seals should be used (see catalogue cards "DIAPHRAGM SEALS").



Temperature applications for Ex versions in accordance with Appendix Ex.02.

7.4 Electrostatic hazards

Plastic rating plate and teflon on the diaphragm seals are non-conductive layer applied on conductive surface. Transmitters in this version should be installed in locations with no possibility of electrostatic charging.

In particular through contact with electrified dust falling or exhaled from devices operating nearby.



For Exi version are valid data by Appendix Ex.02.

7.5. Mechanical Vibration, Corrosive Media

7.5.1. Transmitters should correctly work with vibrations with amplitudes to 1.6 mm and accelerations to 4g. If strong vibrations are carried via the pressure line and disturb of measuring, use should be made of elastic pulse lines or transmitters with a remote diaphragm seal.

7.5.2. Transmitters should not be installed in places where the diaphragm, made of 1.4404/1.4435 (316L) steel, would be subject to corrosion by the medium being measured.



If possible, transmitters with diaphragms made of Hastelloy C276 should be used, or other means of protection applied (e.g. in the form of a separating liquid) or transmitters with diaphragm seals adapted for measuring aggressive mediums according to catalogue cards "DIAPHRAGM SEALS") should be used.

8. INSTALLATION AND MECHANICAL CONNECTIONS

The **APCE...**, **APRE...** transmitters (except APRE-2000G and APR-2000Y) can operate in any position.

When installed on an object with a high-temperature medium, it is advantageous to mount the transmitter in a horizontal position with the packing gland pointing downwards or to the side, in such a way that the transmitter is kept away from the stream of rising hot air.

When the measurement range is small, the reading can be affected by the position of the transmitter and by the configuration of the impulse lines and the way in which they are filled with liquid.

This error can be corrected using the zero-setting function after transmitter installation.

8.1. APCE... Installation and connections

8.1.1. The **APCE...** transmitters can be installed directly on rigid impulse lines.

Where connectors are used as in figures 5a, 6a and 7a, it is recommended that connection sockets be used as shown in figure 5b, 6b, 7b or 7c.

It is recommended that sockets labelled "Socket CG1" and "Socket CG1/2" Fig. 8 are used for CG1 and CG1/2 connections, respectively.

Besides, there are adapters for standard DIN50, (DIN40, DIN25, Clamp2", Clamp1.5", Clamp1") type connections provided for readouts carried out in aseptic conditions using transmitters with CM30x2 connection.

There are seals provided for every transmitter with P, CM30x2, CG1, CG1/2 and GP type connections.

The seal material is selected based on the pressure value and the type and temperature of the medium.

8.1.2. If the pressure is applied via a flexible plastic tube, the transmitter should be mounted on a support with Red Ø6-M reduction. In case of metal pipes, the used connections should comply with PN-82/M-42306. The types of the impulse tubes (Fig. 16) are to be selected depending on the measured value of the pressure and the medium temperature.

8.1.3. Tighten the transmitter in the socket with a torque appropriate for the type of the used seal and the measured pressure.

8.2. APRE... Installation and connections

8.2.1. The **APRE 2000** transmitters can be mounted directly on rigid impulse lines.

To connect the transmitters basic versions, with two M20x1.5 stubs (P-type connector), can be use straight connecting elements with nuts (type C). If elastic impulse lines are used for connection purposes, the transmitter should be additionally fastened to a pipe, panel or supporting construction.

8.2.2. The **APRE-2000** and **APRE-2200** can be installed using the fastener $\varnothing 25$ (figure 17.) on an $\varnothing 25$ pipe or on a flat surface using an angle bracket.

8.2.3. The **APRE-2000** with connecting cover (C-type connector) (figure 10) are designed for installation on 3-valve or 5-valve manifolds to a 2" pipe or to a flat surface using an fastener C-2" (fig.18) or "U" (fig.19).

8.3. APRE-2000G. Installation and connections

8.3.1. The "economy" version of the **APRE-2000G** transmitter can be mounted on a wall, panel or other stable construction, using a clamp with Ø9 holes (Figure 14).

The transmitter is fitted with stubs which fits an Ø 6x1 elastic impulse tube.

When the measured impulse is transmitted via a metal terminal with M20x1.5 opening, an adapter is used between the M20x1.5 thread and the Ø6x1 terminal.

Transmitters should be installed in a vertical position.

Where there is a significant difference between the height at which the transmitter is mounted and the height of the impulse source, particularly if the measurement range is small, the reading may fluctuate depending on the temperature difference between the impulse lines.

This effect can be reduced by ensuring that the lines run side by side.

8.3.2. The **APRE-2000G** transmitter can also be fitted with an adapter (Figure 14) creating a C-type connector, designed for installation on a 3-valve or 5-valve manifold. Aplisens can also supply transmitters ready mounted on valves.

8.4. APR-2000Y. Installation and connections

The **APR-2000/Y** level probes installed in places where liquid levels are measured in closed tanks, with access to medium from top of tank see figure 15 and 10.2.6.

Install the probe in a vertical position.

Pressure may be transmitted to the installed device only after checking that it has a measurement range which properly corresponds to the value of the measured pressure, that gaskets have been properly selected and fitted, and the connector has been properly screwed tight.



Attempts to undo the screws or fixing connector pipes on a transmitter under pressure may cause the medium to leak and create hazards for the personnel.

When disassembling the transmitter, it is necessary to disconnect it from the process pressure or bring the pressure to atmospheric level, and to take particular care and precautions in case of media which are highly reactive, caustic, explosive or otherwise hazardous to personnel.

If necessary, rinse out this part of the system.

Transmitters with flange diaphragm seals are to be installed on the corresponding counterflanges on the facility.



It is recommended that the user matches the screw joints material to the pressure, temperature, flange material and seal to ensure tightness of the flange joint in the expected operating conditions.

Coarse-threaded screws complying with ISO 261 are to be used for flanges used in the APCE..., APRE... transmitters.

Additional data concerning the diaphragm seals are specified in the catalogue cards "DIAPHRAGM SEALS".

9. ELECTRICAL CONNECTION

9.1. General recommendations

It is recommended that twisted pair cabling be used for the signal lines. If the transmitter and signal line are subject to a large amount of electromagnetic interference, then screened twisted pair cable should be used. The signal wires should not run alongside network power supply cables or near to large electrically-powered devices.

The devices used together with the transmitters should be resistant to electromagnetic interference from the transmission line in accordance with compatibility requirements.

It is also beneficial to use anti-interference filters on the primary side of the transformers, the power supplies used for the transmitters and apparatus used in conjunction with them.

9.2. Connections for transmitters with PD-type connector

The transmitters with **PD** type connectors are to be connected as shown in figure 2a.

To make the connections, remove the terminal block from the contact pins together with its cover.

Then remove the block from its cover, levering it off with the end of a screwdriver inserted into the slot provided for this purpose. Connect the wires to the block.



Where the isolation of the wires in the cable gland is ineffective (for example, when single wires are used) the opening of the gland should be carefully sealed with an elastic sealing compound to obtain IP65 ingress protection. It is useful to form the segment of the signal wire leading to the PG-11, PG-9 cable gland into a protective loop to prevent condensation from running down in the direction of the gland.

9.3. Connections for transmitters with terminal box (PZ-type connector)

The transmitters with **PZ**-type connectors should be connected by linking the signal wires to a terminal block, as shown in figure 2a and 2b. Carefully screw in the cover and cork of the packing gland, making sure that the wire is tightly packed. Where necessary, the packing gland should be further sealed as described in 9.2.

9.4. Protection from excess voltage

9.4.1. The transmitters may be in danger from excess voltage caused by connection faults or atmospheric electrical discharge. Protection from excess voltage between the wires of the transmission line is provided by TVS diodes installed in all types of transmitter (see the table, column 2).

9.4.2. In order to protect against excess voltage between the transmission line and the casing or earth (not prevented by the diodes connected between the transmission wires), additional protection is provided in the form of plasma surge arresters or TVS diodes (see the table, column 3).

In the case of unprotected transmitters, external protective devices may be used, e.g. the UZ-2 system produced by Aplisens, or others. When the transmission lines are long, it is advantageous to use one protective device near the transmitter (or inside it), and another near entry points to other devices used in conjunction with it.

Internal protection of transmitters:

1	2	3
Type of transmitter	Protection between wires (transil diodes) – permitted voltage	Protection between wires and earth and/or casing – type of protection, permitted voltage
APCE..., APRE...	39V DC	Plasma surge arresters - 100V DC (for normal and SA version)

9.4.3. The voltage in the protective elements must not exceed the maximum permitted values given in columns 2 and 3 of the table.



The insulation test voltages (500V AC or 750V DC) given in 5.1.1 refer to transmitters without plasma surge arresters - such protection is not used in Ex versions of transmitters.

9.5. Earthing

The transmitters are fitted with internal and external earth terminals.

10. SETTING AND REGULATION

APCE..., **APRE...** transmitters are factory calibrated to the range stated in the order or to the basic range.

After installation, the transmitter's zero-point may drift and require adjustment.

This applies particularly in cases where the measurement range is small, where the impulse lines are filled with a separating liquid or where **APCE...**, **APRE...** transmitters are used with remote diaphragm seals.

10.1. Transmitter Range, Definitions

10.1.1. The maximum range of absolute or differential pressure which the transmitter can measure is called the **“basic range”** (for specifications of basic ranges see 5.2.1, 5.3.1, 5.4.1 and 5.5.1 and 5.6.1).

The width of the basic range is the difference between the upper and lower limits of the basic range.

The internal characteristic conversion curve for the basic range is coded in the transmitter's memory.

This is the reference curve used when making any adjustments which affect the transmitter's output signal.

10.1.2. When the transmitter is in use the term **“set range”** is used. The set range is the range whose lower end-point corresponds to an output current of 4mA and whose upper end-point corresponds to a current of 20mA (or 20mA and 4mA respectively when the conversion curve is inverted).

The set range may cover the whole of the basic range or only a part of it.

The width of the set range is the difference between its upper and lower end-points.

The transmitter may be set to any range within the basic range of pressure values, subject to the restrictions set out in the table in 5.2.1, 5.3.1, 5.4.1, 5.5.1 and 5.6.1.

10.2. Configuration and Calibration

10.2.1. The transmitter has features which enable metrological and identification parameters to be set and altered. The configurable metrological parameters affecting the transmitter's output current include the following:

- a) unit in which the measured pressure is expressed on the display;
- b) upper end-point of the set range;
- c) lower end-point of the set range;
- d) time constant;
- e) type of characteristic curve: linear or radical.

Parameters of an informational nature which cannot be altered include the following:

- f) upper limit of the maximum range;
- g) lower limit of the maximum range;
- h) minimum range.

10.2.2. Other identification parameters, not affecting the output signal, include: device address, device type code, factory identification code, factory device code, number of preambles (3÷20), UCS, TSD, program version, electronics version, flags, factory number, label tag, description tag, date tag, message, record number, sensing module number.

The process of setting the parameters listed in 10.2.1 and 10.2.2 is called **“Configuration”**.

10.2.3. It is possible to carry out a **“pressure zeroing”** procedure, for example in order to compensate for measurement deviation caused by a change in position when the transmitter is installed.

The transmitter may also be **calibrated**, by taking readings with the input pressure controlled using a standard device. This process and zero-point adjustments are called **“Calibration”**.

10.2.4. Configuration and Calibration of the transmitter are carried out using an Aplisens KAP-03 communicator, certain HART communicators or a PC with HART/RS232 or HART/USB/Bluetooth Converter and Aplisens Raport 2 software.

Together with the “RAPORT 2” configuration software there is “INTERVAL LINEARIZATION” software supplied to enable the input of 21-point nonlinear functional characteristics to the transmitter.

A description of the functions of the KAP communicator is contained in the KAP Communicator Operating Manual.



A list of HART protocol commands implemented for APCE..., APRE... transmitters is contained in the IO.HART operating instructions available at www.aplisens.pl.



After configuration it is important to protect the transducers using command HART [247]. During work transmitter should be safe prior to entries. This prevents accidental or intentional changes configurational data. The protection function is accessible in KAP-03 communicator, “Raport's 2” software, as well as, in applying DD or DMT programs libraries.

10.2.5. Configuration of the APRE-2200 transmitters to measure the level, density of liquid and phase boundary

To simplify the mathematical operations we introduce the density coefficient of the medium $X\rho$.

$$X\rho = \frac{\rho_{\text{medium}} [\text{g/cm}^3]}{\rho_{\text{water at 4}^\circ\text{C}} [\text{g/cm}^3]}$$

Since the density of water at 4°C is 1 g/cm³, the density coefficient $X\rho$ is numerically equal to the density of the medium expressed in g/cm³. To determine the hydrostatic pressure of a column of liquid in mm H₂O, it is sufficient to multiply the height of the column h [mm] by the density coefficient of the liquid $X\rho$. Since it is easy to determine the hydrostatic pressure in mm H₂O and the transmitter can be configured in those units, in the descriptions of measurement methods given below we will make use of pressures expressed in mm H₂O and the density coefficient $X\rho$.

Configuration of the APR-2200 transmitter to measure the level of liquid in a tank

The measurement task:

To convert a variation in the level of a liquid with density $\rho = 0.87 \text{ g/cm}^3$ between 0 and h_{max} to a variation in the output signal from 4 to 20 mA.

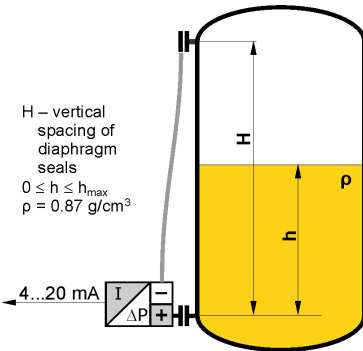

1. Install the transmitter in its working position on an empty tank.
2. Make the electrical connections of the transmitter, providing for the ability to use HART communication.
3. Connect the KAP-01 communicator, identify the transmitter and select the "configuration" function.

4. On the configuration menu select the "Reranging" procedure.
5. On the "Reranging" menu:
 - a) change the units of measurement to mm H₂O at 4°C;
 - b) enter the values for the start ($X\rho \times h_{\text{min}}$ [mm]) and end ($X\rho \times h_{\text{max}}$ [mm]) of the measurement range, namely 0 and ($0.87 h_{\text{max}}$ [mm]) respectively;
 - c) to compensate for the hydrostatic pressure of the manometric fluid, the start of the measurement range should be set using regulated pressure; when subject to the action of only the manometric fluid (empty tank) the transmitter will shift the start and end-points of the range, compensating for the value of that pressure.

When the transmitter has been configured in this way it is ready to be used to carry out the given measurement task.

If it is not possible to empty the tank to configure the transmitter, the hydrostatic pressure of the manometric fluid should be calculated by multiplying the vertical spacing of the diaphragm seals by the density coefficient of the oil in the capillaries. This pressure should be taken into account when entering the values for the start and end of the range:

Start [mm H₂O] = $-H$ [mm] $\times X\rho_{\text{oil}}$

End [mm H₂O] = h_{max} [mm] $\times X\rho_{\text{measured liquid}} - H$ [mm] $\times X\rho_{\text{oil}}$

ρ_{oil} for DC-550 oil is equal to 1.068 g/cm³
 ρ_{oil} for AK-20 oil is equal to 0.945 g/cm³

Configuration of the APR-2200 transmitter to measure density of liquids

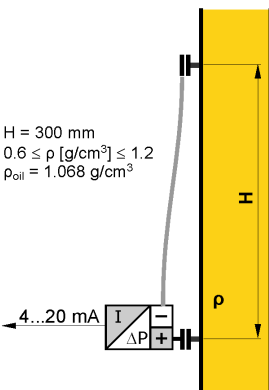

The measurement task:

To convert a variation in liquid density from $\rho_{\text{min}} = 0.6 \text{ g/cm}^3$ to $\rho_{\text{max}} = 1.2 \text{ g/cm}^3$ to a variation in the output signal from 4 to 20 mA, with the vertical spacing of the diaphragm seals equal to $H = 3000 \text{ mm}$. The sealing system is filled with DC-550 oil with density $\rho_{\text{oil}} = 1.068 \text{ g/cm}^3$.

1. Calculate the value of the start of the range as follows:
 $H_{[\text{mm}]} \times (X\rho_{\text{min}} - X\rho_{\text{oil}}) = 3000 \times (0.6 - 1.068) = -1404 \text{ [mm H}_2\text{O]}$
2. Calculate the value of the end of the range as follows:
 $H_{[\text{mm}]} \times (X\rho_{\text{max}} - X\rho_{\text{oil}}) = 3000 \times (1.2 - 1.068) = 396 \text{ [mm H}_2\text{O]}$
3. Set the zero point of the transmitter with the diaphragm seals positioned at the same level.
4. Install the transmitter in its working position.
5. Make the electrical connections to the transmitter, providing for the possibility of using HART communication.

6. Connect the KAP-01 communicator, identify the transmitter and select the "configuration" function.
7. On the configuration menu select "Reranging" procedure.
8. On the "Reranging" menu:
 - a) change the measurement units to mm H₂O at 4°C;
 - b) enter the calculated values for the start (-1404) and end (396) of the range.

When the transmitter has been configured in this way it is ready to be used to carry out the given measurement task.

Note: If it is possible to fill the space between the seals with a liquid whose density corresponds to the start of the measurement range, the start of the range of the transmitter can be set using regulated pressure.

Measurement of phase boundary

The height of the phase boundary of liquids of different densities is determined by measuring the average density of the medium between the seals.

Example:

Calculate the measurement range start and end points for an APR-2200 transmitter configured to measure phase boundary height in the range 0–1000 mm between liquids of density $\rho_1 = 0.7 \text{ g/cm}^3$ and $\rho_2 = 1.0 \text{ g/cm}^3$, where the vertical spacing of the seals $H = 1600 \text{ mm}$. The sealing system uses DC-550 oil with a density of 1.068 g/cm^3 .

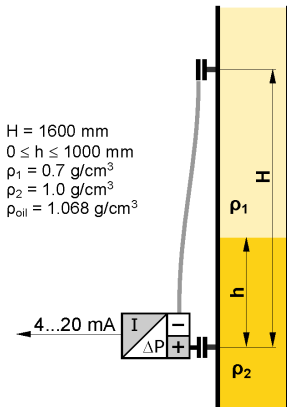

To determine the start of the measurement range, calculate the pressure difference at the transmitter when the tank is filled with the lighter liquid only:

$$1600 [\text{mm}] \times (0.7 - 1.068) = -588.8 [\text{mm H}_2\text{O}]$$

To determine the end-point of the range, add the increase in pressure resulting from the appearance of a 1 metre column of the heavier liquid:

$$-588.8 [\text{mm H}_2\text{O}] + (1.0 - 0.7) \times 1000 [\text{mm}] = -288.8 [\text{mm H}_2\text{O}]$$

Additional remarks

The settings of the transmitter can be adjusted with reference to laboratory results from density measurements carried out on samples of the liquid being measured. This is most often necessary when the measurement takes place in a pipeline segment where the flow velocity of the measured liquid reaches several m/s.

Increasing the vertical spacing of the diaphragm seals widens the range and often improves measurement accuracy.

In planning the spacing of the diaphragm seals, ensure that the pressure difference at the transmitter lies within the basic range.

The maximum vertical spacing of the diaphragm seals (H) depends on the transmitter's basic range and the boundary values for the density of the measured liquid (ρ_{min} ; ρ_{max}).

If $\rho_{\text{min}} < \rho_{\text{oil}} < \rho_{\text{max}}$, the seal spacing H should satisfy the following conditions:

$$H [\text{mm}] \leq \frac{\text{lower boundary of range [mm H}_2\text{O}]}{X\rho_{\text{min}} - X\rho_{\text{oil}}}$$

$$H [\text{mm}] \leq \frac{\text{upper boundary of range [mm H}_2\text{O}]}{X\rho_{\text{max}} - X\rho_{\text{oil}}}$$

Example:

Determine the maximum vertical spacing of the seals for the APR-2200 / -10...10 kPa transmitter when measuring the density of liquid between 0.6 and 1.2 g/cm³. The sealing system uses AK-20 silicone oil with a density of 0.945 g/cm³.

The lower boundary of the range of the transmitter is -10 kPa = -1020 mm H₂O

$$H [\text{mm}] \leq \frac{-1020}{0.6 - 0.945} \Rightarrow H [\text{mm}] \leq \frac{-1020}{-0.345} \Rightarrow H [\text{mm}] \leq 2957$$

The upper boundary of the range of the transmitter is +10 kPa = 1020 mm H₂O

$$H [\text{mm}] \leq \frac{1020}{1.2 - 0.945} \Rightarrow H [\text{mm}] \leq \frac{1020}{0.255} \Rightarrow H [\text{mm}] \leq 4000$$

In the example, both conditions are satisfied when the spacing of the seals is not more than 2957 mm.

10.2.6. Configuration of the APR-2200Y smart level probes.

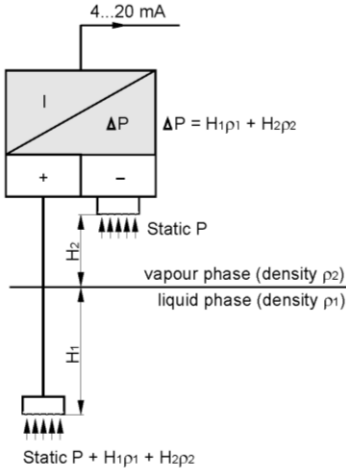

Principles of operation

Measurement is carried out using an APR-2000 differential pressure transmitter, enabling compensation for static pressure in the tank. The value processed is just the hydrostatic pressure of the medium measured at the level of the diaphragm of the lower seal. This pressure is the sum of the hydrostatic pressures of the liquid and vapour phases of the medium. In most practical measurement situations the density of the vapour phase is negligibly small, and therefore the measured hydrostatic pressure relates only to the height of the liquid phase column and can be taken as representing the level of the surface of the liquid phase. For media where the density of the vapour phase is significant (e.g. propane) the level found by the method described can be treated as the theoretical level of the liquid level obtained by adding the actual liquid phase to the condensed vapour phase.

Example of installation on a tank

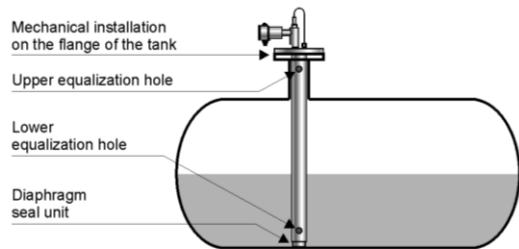

Configuration example

To convert a rise in the level of liquid with density 0.87 from 0 to 3200 mm to a current change from 4 to 20 mA.

1. Install the transmitter in working position, place the seal at the appropriate height (tank empty).
2. Calculate the width of the measurement range in mm H₂O (4°C): $3200 \text{ mm} \times 0.87 \text{ g/cm}^3 = 2784 \text{ mm H}_2\text{O}$.
3. Using the communicator, set the transmitter to use the units **mm H₂O at 4°C**.
4. To determine the start of the measurement range, read off via the communicator the hydrostatic pressure produced by the manometric fluid in the capillary (e.g. **-4250 mm H₂O**).
5. To determine the end-point of the measurement range, add the value -4250 mm H₂O and the width of the measurement range $-4250 \text{ mm H}_2\text{O} + 2784 \text{ mm H}_2\text{O} = -1466 \text{ mm H}_2\text{O}$.
6. Using the communicator enter the calculated start (**-4250 mm H₂O**) and end-point (**-1466 mm H₂O**) of the measurement range and send as a block to the transmitter. After receiving these parameters the transmitter will perform measurements as required.

11. SERVICES AND SPARE PARTS.

11.1. Periodic service

Periodic service should be made in accordance with the user regulations. During service, the pressure connectors should be checked for loose connections and leaks, the diaphragm seals should be checked for tarnishing and corrosion, and the electrical connectors should be checked with regard to tightness the state of the gaskets, packing glands, and. If necessary check the transmitter measure characteristic by following the procedures for "Calibration" and, where appropriate, "Configuration".

11.2. Unscheduled inspections

If the transmitters are installed in a location where they may be exposed to mechanical damage, excess pressure, hydraulic impulses or excess voltage, or the diaphragm may be in danger from sedimentation, crystallization or erosion, inspections should be carried out as required.

Where it is found that the signal in the transmission line is absent or its value is incorrect, a check should be made on the line and its terminal connections.

Check whether the values of the supply voltage and load resistance are correct.

If a communicator is connected to the power supply line of the transmitter, a fault in the line may be indicated by the message "No response" or "Check connection".

If the line is in order, check the operation of the transmitter.

11.3. Cleaning the Diaphragm Seal, Overloading Damage

11.3.1. Sediment and dirt which have formed on the diaphragm in the course of operation must not be removed by mechanical means, as this may damage both the diaphragm and the transmitter itself. The only permitted method is the dissolving of sediment.

11.3.2. Sometimes transmitters malfunction due to damage caused by overloading, e.g. in case of:



- **application of excessive pressure;**
- **freezing or solidification of the medium;**
- **action of a hard object, such as a screwdriver, on the diaphragm.**

Usually in such cases the symptoms are such that the output current falls below 4mA or rises above 20mA, and the transmitter fails to respond to input pressure.

11.4. Spare parts.

The following transmitter parts may need replacing due to damage or normal wear

- transmitters with PD connector: terminal block with angular cover and seal, connector base with seal, rating plate, case;
- transmitters with PZ connector: cover seal and packing gland.

In the Ex version, the user may replace only the terminal block with angular shield and the seal in the PD connector, or the seal and packing gland in the PZ connector.



Other parts, due to their special characteristics and anti-explosive requirements, may be replaced only by the manufacturer or an authorized firm.

12. PACKING, STORAGE AND TRANSPORT

The transmitters should be packed singly or in sets, in such a way as to protect them from damage during transportation.

The transmitters should be stored in multiple packs under cover, in a place free of vapours and reactive substances, with temperature and humidity does not exceed the permissible ambient and operational parameters.

Transmitters with uncovered diaphragm or seal connectors, stored without packaging, should have covers to prevent damage to the diaphragm.

During transportation, the transmitters should be packed and secured so as to prevent them from shifting.

Any means of transport may be used, provided direct atmospheric effects are eliminated.

13. GUARANTEE

Manufacturer warrants under the conditions specified in the Product Certificate which is also a guarantee card.

14. ADDITIONAL INFORMATION

The manufacturer reserves the right to make constructional and technological changes which do not lower the quality of the transmitters.

14.1. Related documents

- "KAP-03– Communicator Operating Manual" supplied with the Aplisens communicator.
- "Raport 2" software.
- "INTERVAL LINEARIZATION" software.

14.2. Related standards

PN-EN 60529:2003	Degrees of protection provided by enclosures (IP Code).
PN-EN 61010-1	Safety requirements for electrical equipment for measurement, control and laboratory use. General requirements.
PN-82/M-42306	Screwed connectors of pressure gauges.
PN-81/M-42009	Automatics and industrial measurements. The packing, the storage and transport of devices. General requirements.
PN-EN 1092-1:2004 (U)	Flanges and their joints – Circular flanges for pipes, valves, fittings and accessories. – Part 1: Steel flanges.

15. FIGURES

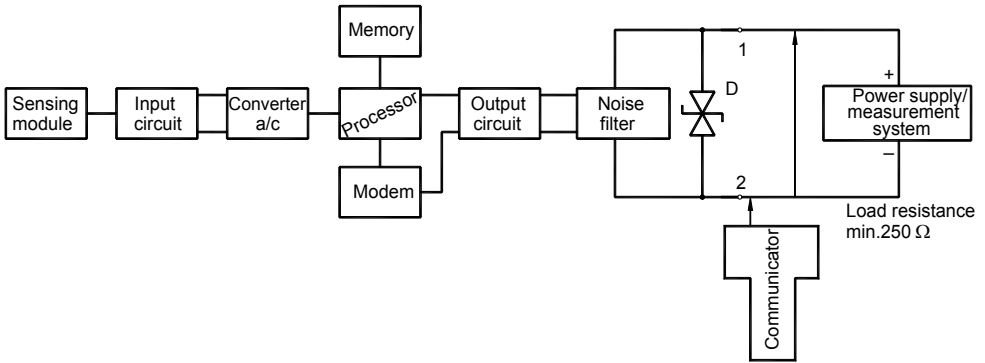

Fig. 1. APCE..., APRE... transmitters – block diagram.

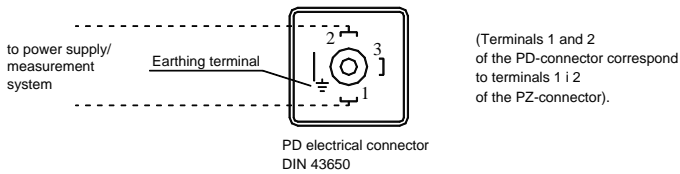

Fig. 2a

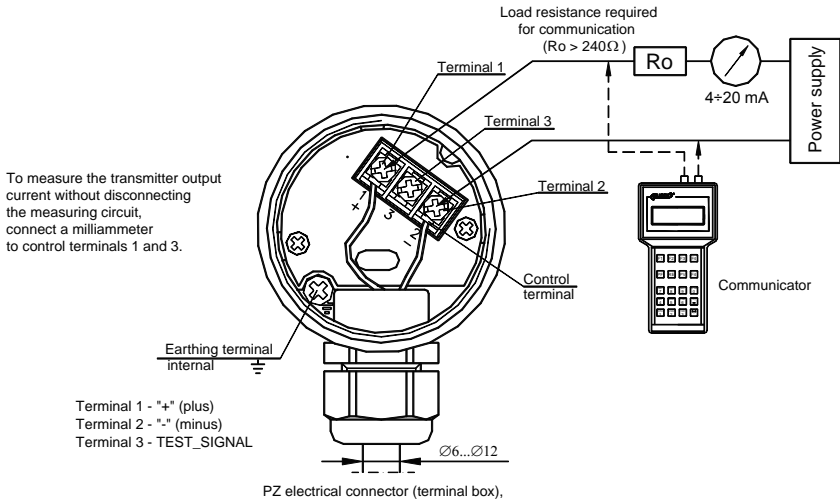

Fig. 2b

Connecting the communicator

If the resistance (R_o) seen from the transmitter to the line direction is greater than $> 240\Omega$, is possible communicate to the transmitter via a connection to measurement line. ($R_o = \text{line resistance} + \text{load}$).

If $R_o < 240\Omega$, there will be no communication and resistance in the line should be increased to at least 240Ω .

Communicator should be connected to current loop as at Fig. 2b. It may be made both: in connecting box or to transmitter terminals.

The voltage fall on installed R_o resistor should be considered by establishing the voltage supply in transducer measured line (see p. 5.1.1.); necessary to verify isn't resistance sum in current loop exceed (see fig.2b).



Fig. 2. Electrical connections for APCE..., APRE... transmitters.

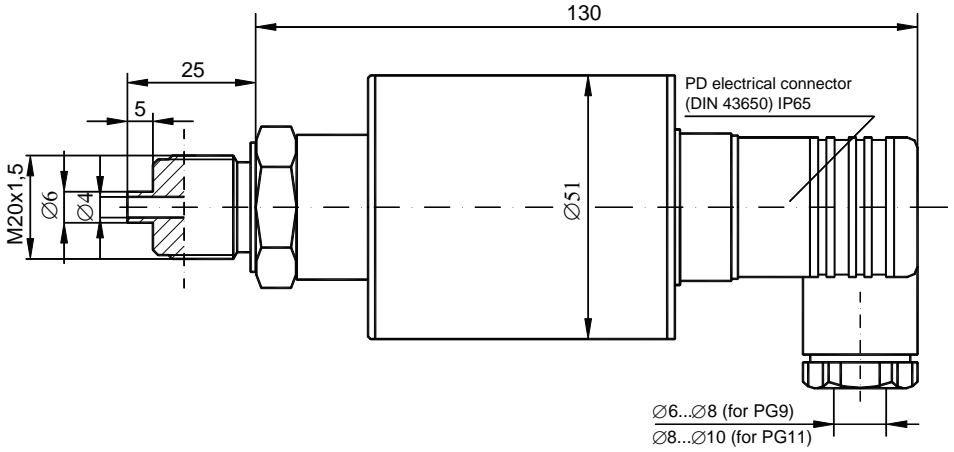

Fig. 3. APCE-2000 transmitter with PD connector.

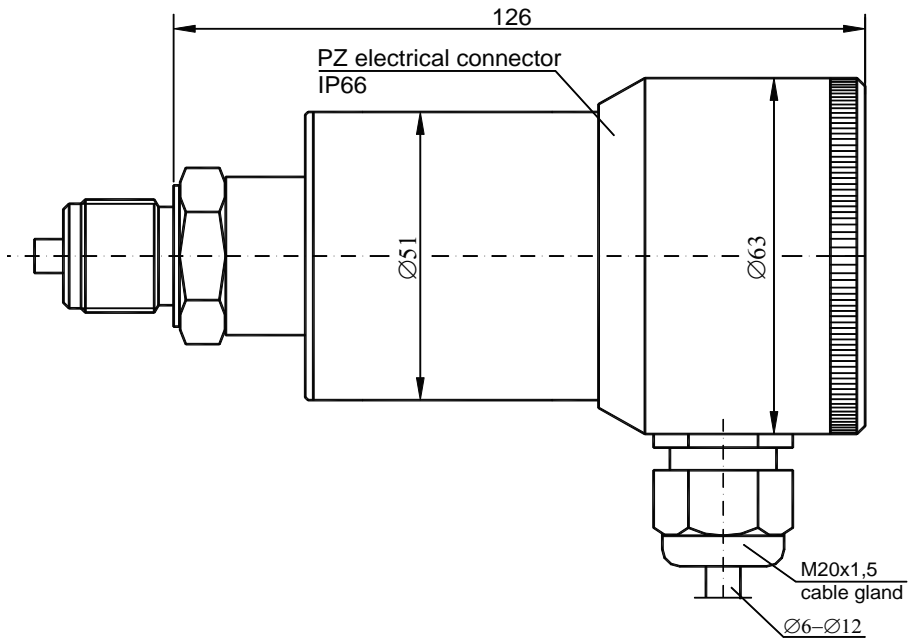

Fig. 4. APCE-2000 transmitter with PZ connector.

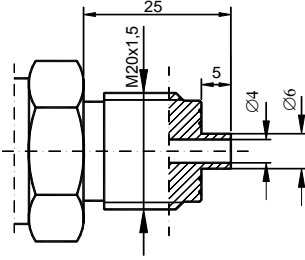

Fig.5a. M-type connector with M20x1.5 thread.

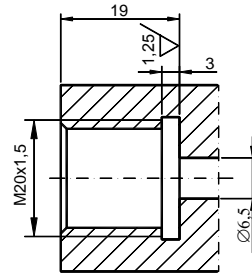

Fig.5b. Socket for use with transmitters with M-type connector.

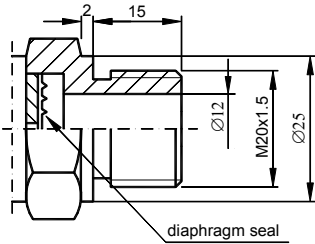

Fig.6a. P-type connector with M20x1.5 thread.

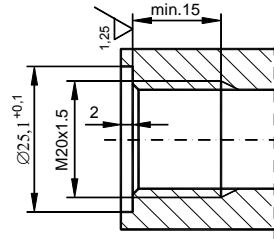

Fig.6b. Socket for use with transmitters with P-type connector P.

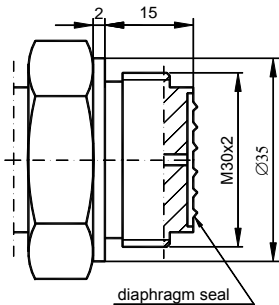

Fig.7a. CM30x2-type connector with flush diaphragm with M30x2 thread.

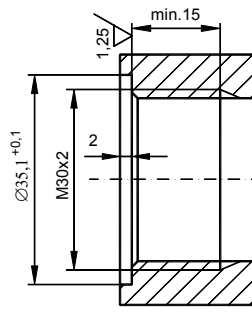

Fig.7b. Socket for use with transmitters with CM30x2-type connector with flush diaphragm.

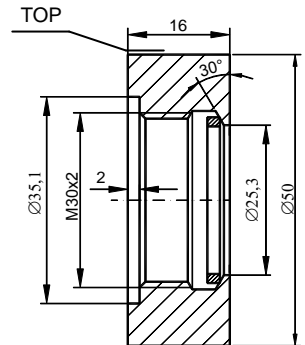

Fig.7c. Weldable fitting ring for use with transmitters with CM30x2-type connector
Material: 316Lss
Sealing: teflon

Order code Socket CM30x2



The ring in Fig. 7c must be welded in place with the word TOP upwards

Fig. 5. M-type connector with M20x1.5 thread.

Fig. 6. P-type connector with M20x1.5 thread.

Fig. 7. CM30x2-type connector with flush diaphragm with M30x2 thread.

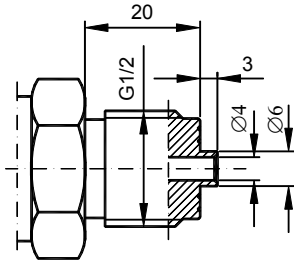

Fig.8a. G1/2-type connector with G1/2" thread.

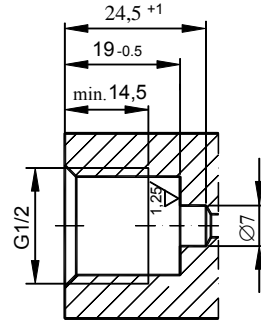

Fig.8b. Socket for use with transmitters with G1/2-type connector.

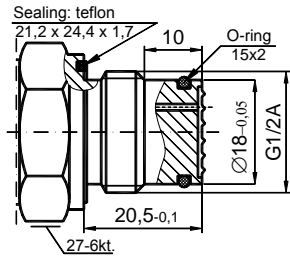

Fig.8c. CG1/2 -type connector with flush diaphragm with G1/2" thread.

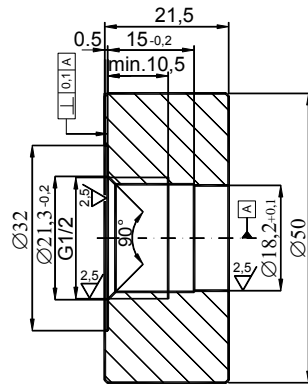

Fig.8d. Weldable fitting ring for use with transmitters with CG1/2 - type connector
Material – 316Lss
Order code Socket CG1/2

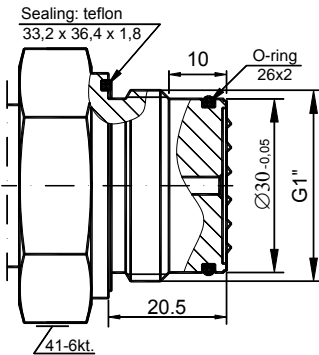

Fig.8e. CG1-type connector with flush diaphragm with G1" thread.

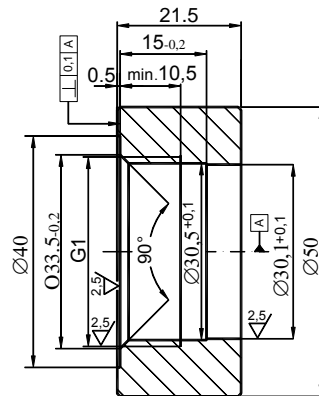

Fig.8f. Weldable fitting ring for use with transmitters with CG1 - type connector
Material – 316Lss
Order code Socket CG1

Fig. 8. G1/2" and G1" Process connections.

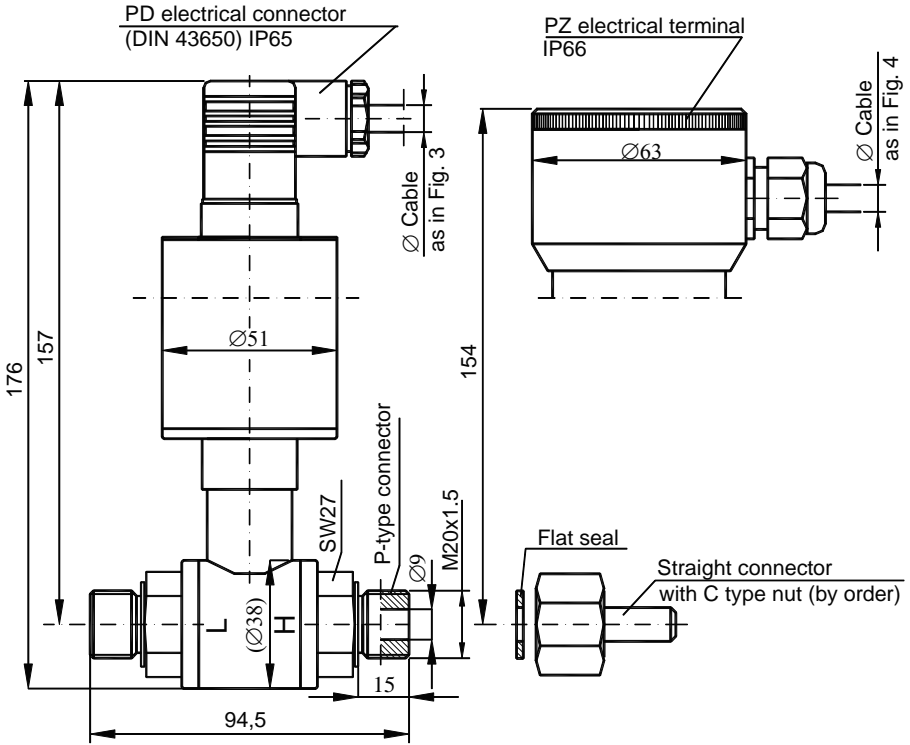

Fig. 9. APRE-2000 differential pressure transmitter with P-type connector.

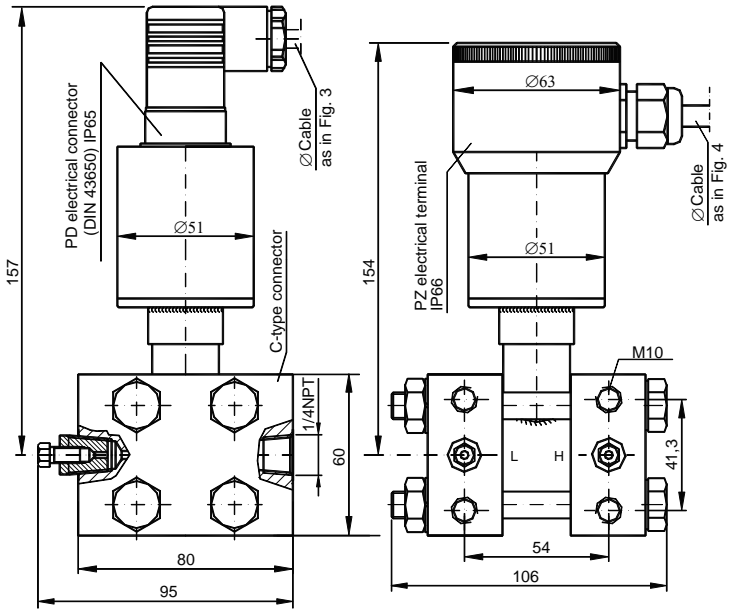

Fig. 10. APRE-2000 differential pressure transmitter with C type vented covers.

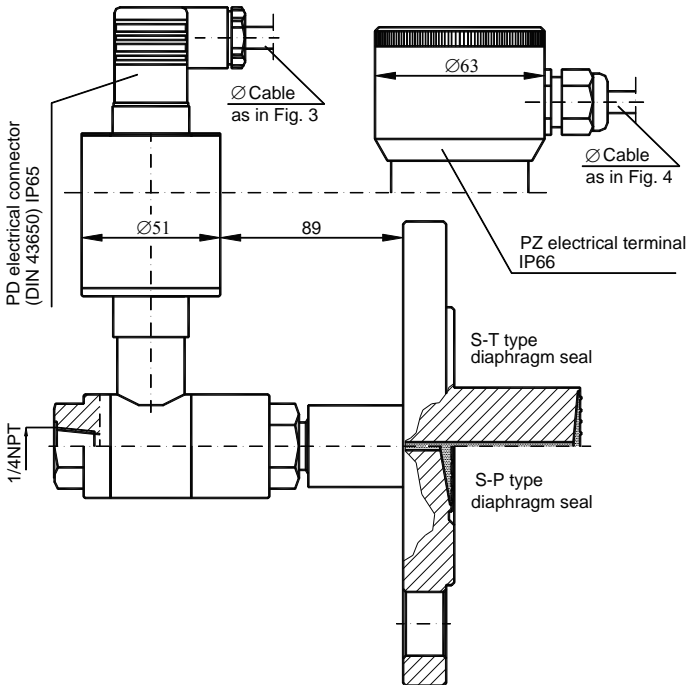

Fig. 11. APRE-2000 differential pressure transmitter with a single direct diaphragm seal (examples).

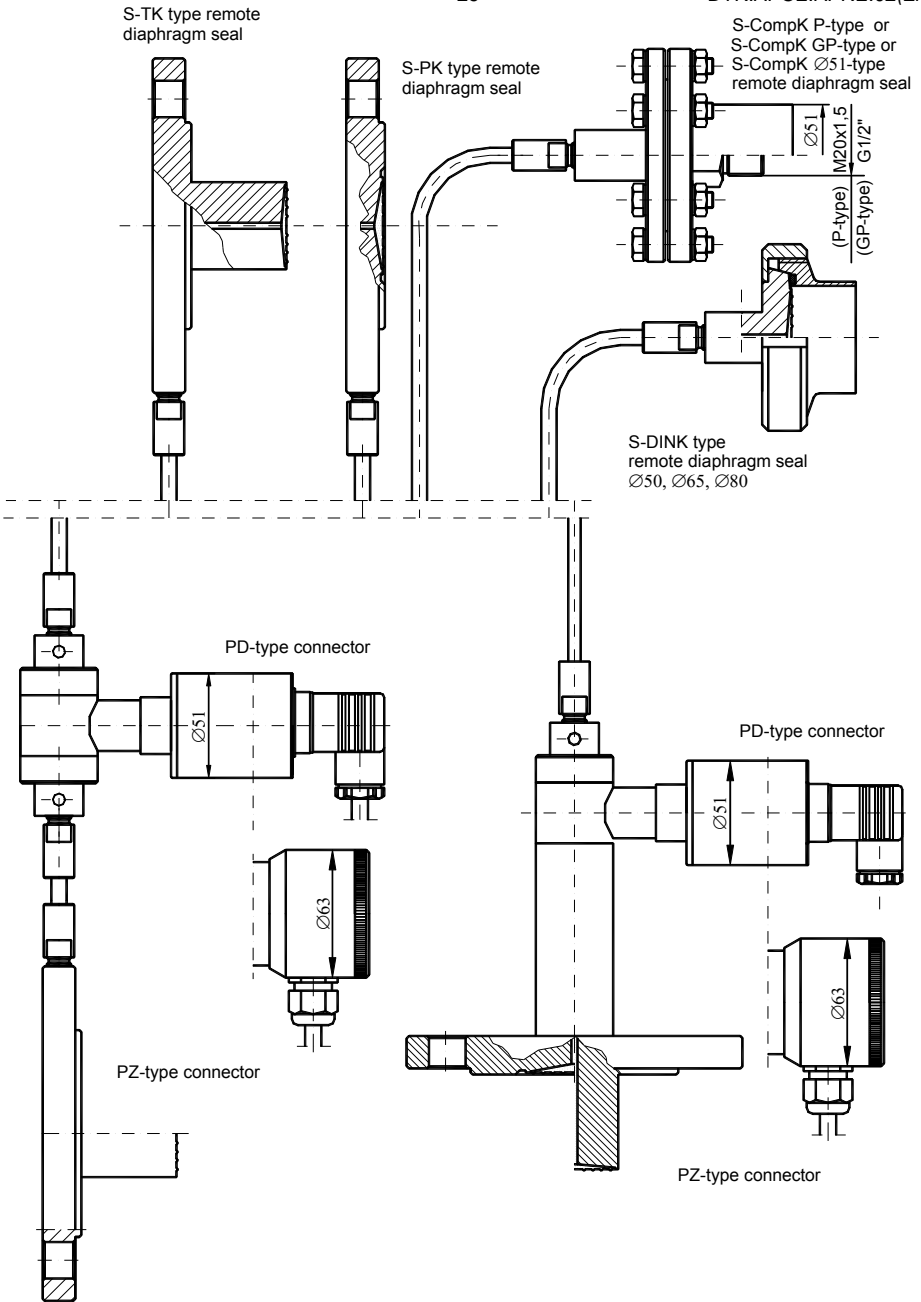

Fig. 12. APRE-2200 differential pressure transmitter with two remote diaphragm seals (examples).

Fig. 13. APRE-2200 differential pressure transmitter with direct diaphragm seal and remote diaphragm seal (examples).

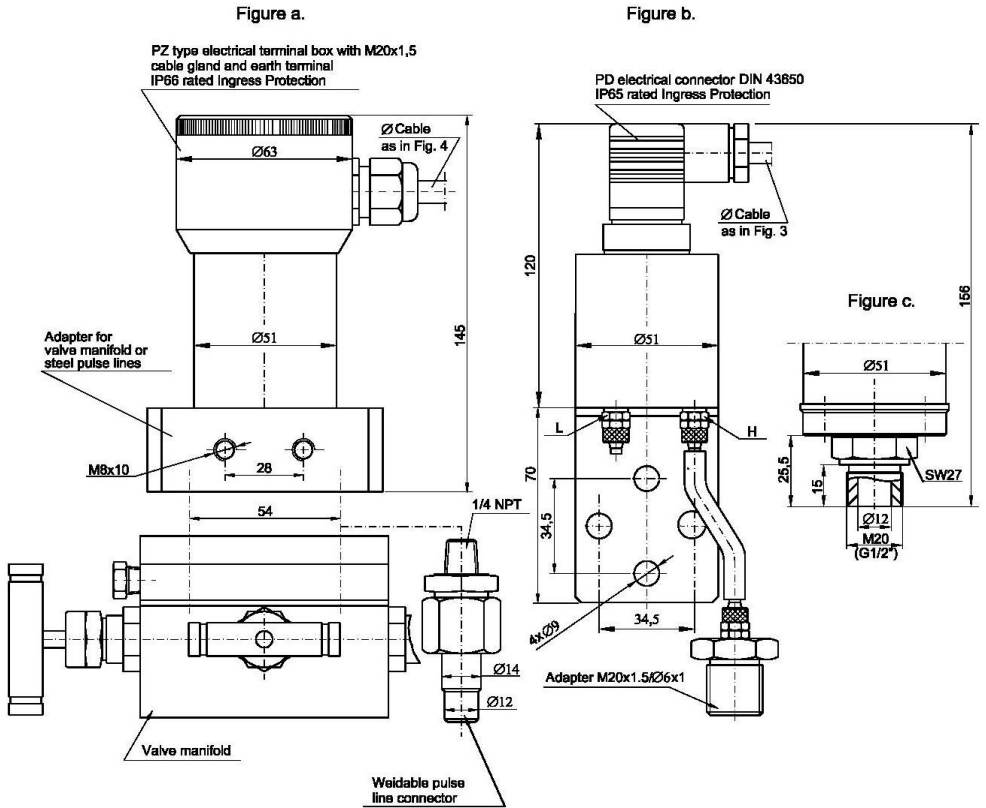

Fig. 14. APCE-2000G Pressure transmitter and APRE-2000G Differential pressure transmitter for low ranges.

- APRE-2000G transmitter – industrial version with C type process connector to mount together with a valve manifold or weldable impulse line connectors.
An example with PZ type electrical connector.
- APRE-2000G transmitter – economical version with PCV type process connector.
- APCE-2000G, APRE-2000G transmitter – with GP or P type process connector (G1/2" or M20x1.5 thread).

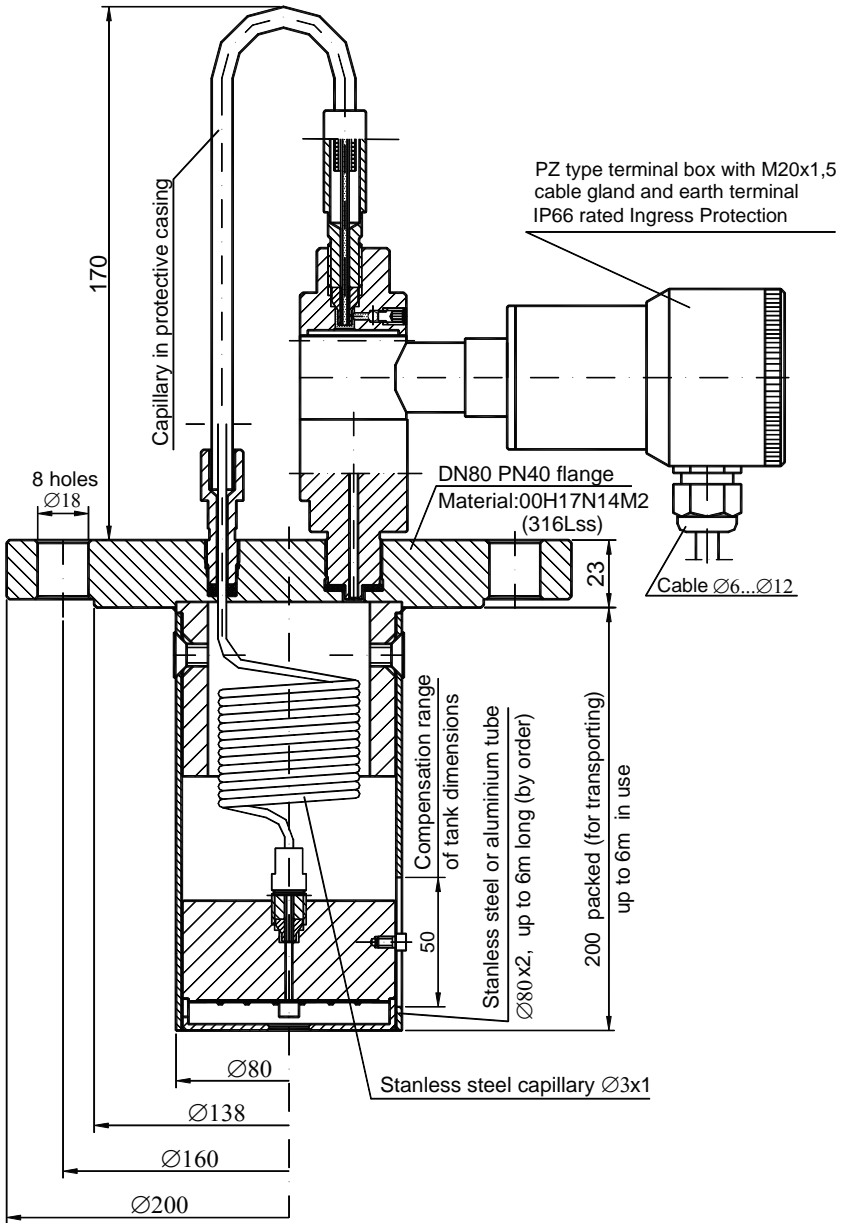

Fig. 15. APR-2000Y Level probe for pressure tanks.

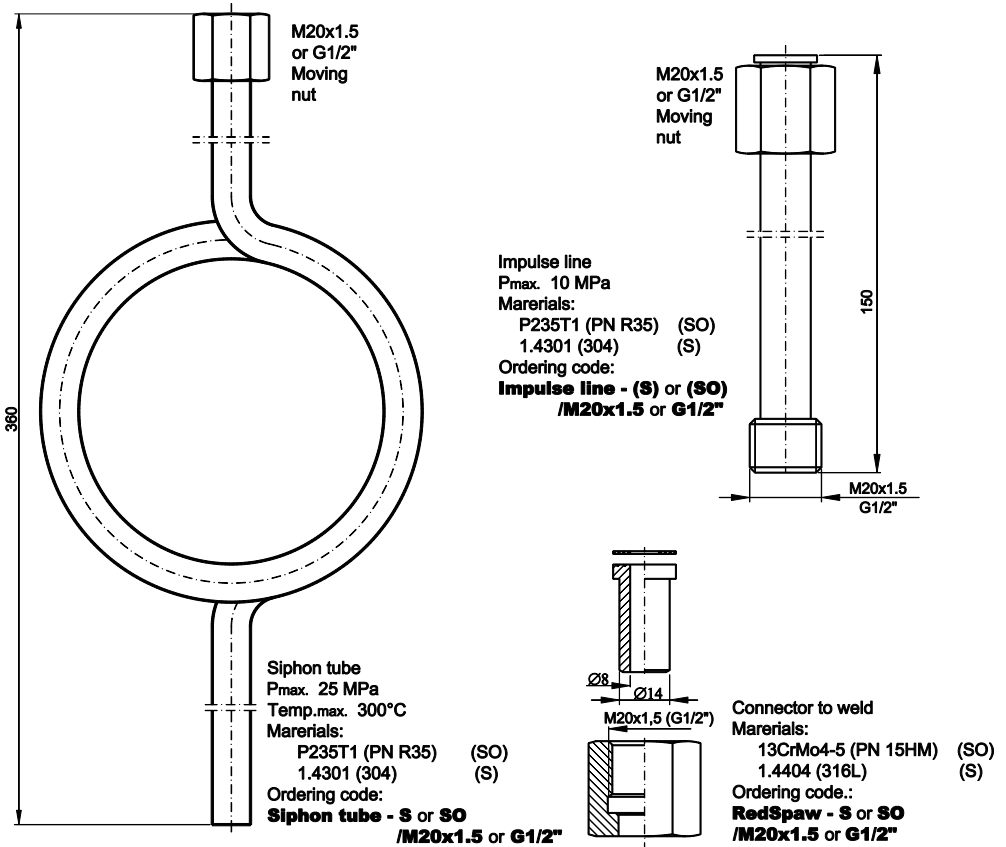

Fig. 16. Additional equipment for fitting of pressure transmitters.

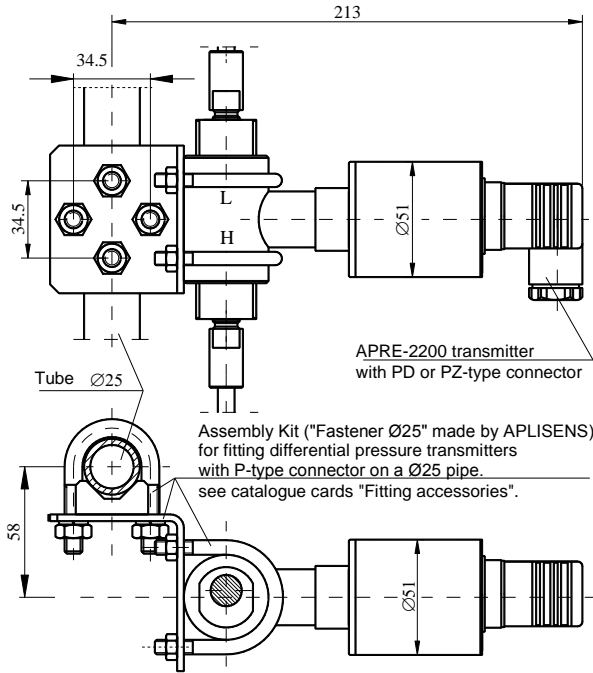

Fig. 17. Example: how to install the APRE-2200 transmitters with remote diaphragm.

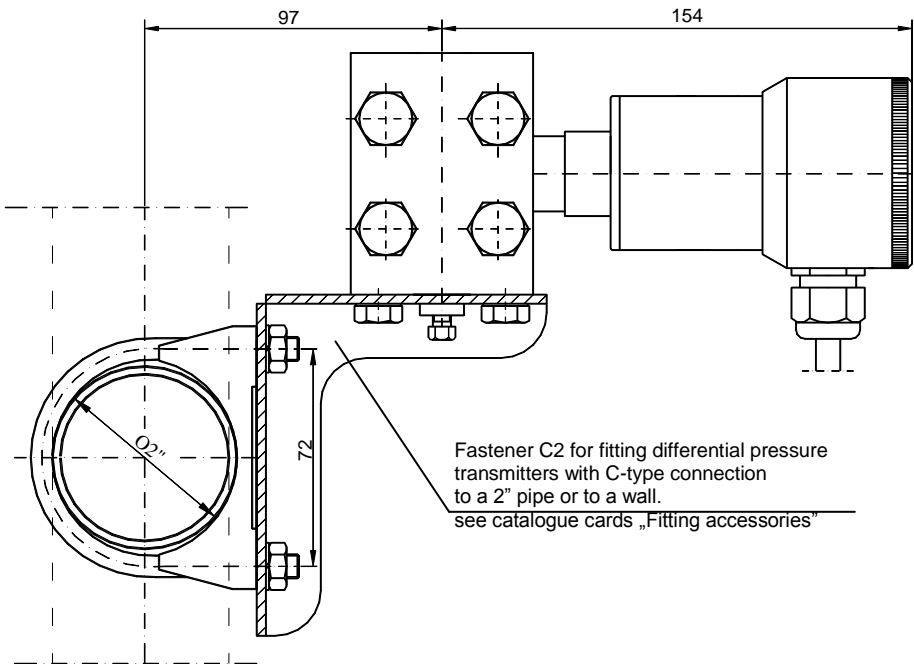

Fig. 18. Example: how to install the APRE-2000 transmitter on a vertical or horizontal pipe.

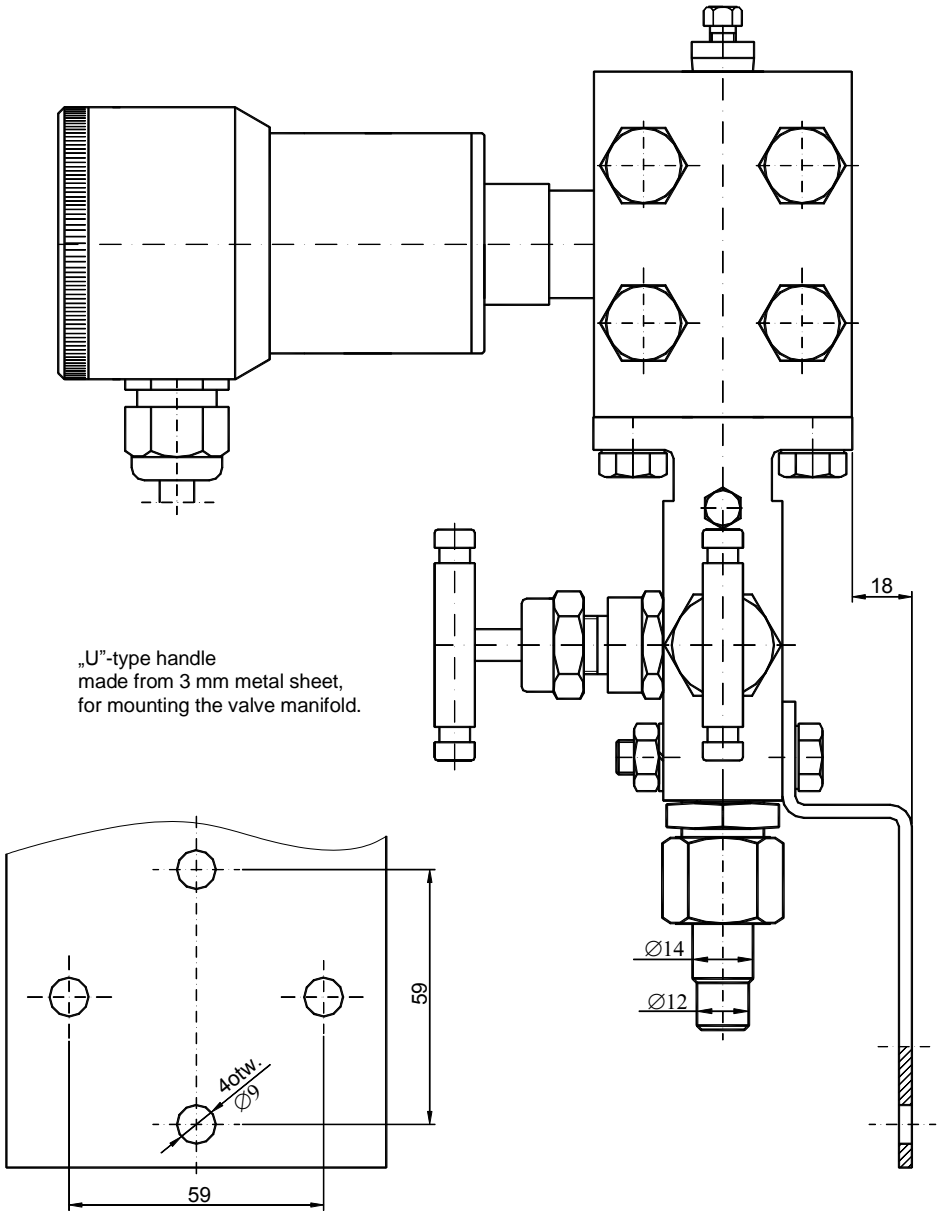

Fig. 19. Example: how to install the APRE-2000 transmitter with a valve manifold to a wall.

