



MAN000949  
Classification: Public

## Technical Data Sheet

### C – Series



## 1 Notes and Warnings

### Attention!

This description is not a substitution for the concerned product's documentation. Please do read the documentation including the manuals carefully before dealing with this product. If the safety instructions in the documentation are not followed dangerous situation can occur that can result in damages, injuries and/or death by high voltage or wrong handling. In case you do not have the correct documentation, you can order it by contacting **opus-support@topcon.com**. Only properly trained personnel with the correct qualification are allowed to handle the device.

### Attention!

Do not open the housing to avoid danger to high voltage. Before touching the electric assemblies make sure that the electricity is switched off completely. If the front panel is broken the device needs to be taken out of service due to risk of injury. If perceivable damages on the device exist that can compromise the functionality, it must be taken out of service due to the danger of malfunctions. These particularly include damages to the LCD display, damages to the keyboard, damages that compromise the protection level and damages to the encoder knobs.

### Please note:

All content is subject to change without notice. Errors and omissions excepted.

### Mounting and Handling

- Do not use the cable as a handle to carry the device.
- Mounting in clean working environment only.
- Do not mount the device under the use of violence because it can cause damage.
- The device must be mounted by trained personnel only into especially designed and tested system.
- The device may not be opened or disassembled.
- The device is to be cleaned with a moist fuzz free cotton cloth. If necessary, a mild cleaning agent may be used. Do not use acid or abrasive cleaning agents.
- The device is to be stored in a cool and dry environment and to be protected against sunshine.
- If the environmental temperature is beneath 10°C the reaction time of the display increases.
- Picture sticking is possible at higher temperatures if no screensaver is used
- Pressurized air must not be used to clean the device to prevent damage of the internal microphone.

## 2 General Information

### Order numbers

This documentation is valid for **OPUS C - Series** order numbers as follows:

	OPUSC07EN1CAN000	OPUSC07EN1CDS000	OPUSC07EN1UTS000	OPUSC07EN1UTM000	OPUSC07EN1UTL000
	OPUSC10EN1CAN000	OPUSC10EN1CDS000	OPUSC10EN1UTS000	OPUSC10EN1UTM000	OPUSC10EN1UTL000
	OPUSC12EN1CAN000	OPUSC12EN1CDS000	OPUSC12EN1UTS000	OPUSC12EN1UTM000	OPUSC12EN1UTL000
<b>OPUS Projektor</b>	•				
<b>CODESYS®</b>		•			
<b>ISO-Horizon</b>			•	•	•

The version (7), (10) and (12) are corresponding to the according display sizes: 7“, 10.1“ and 12.1“



## Dimensions 10.1" (OPUSC10\*)

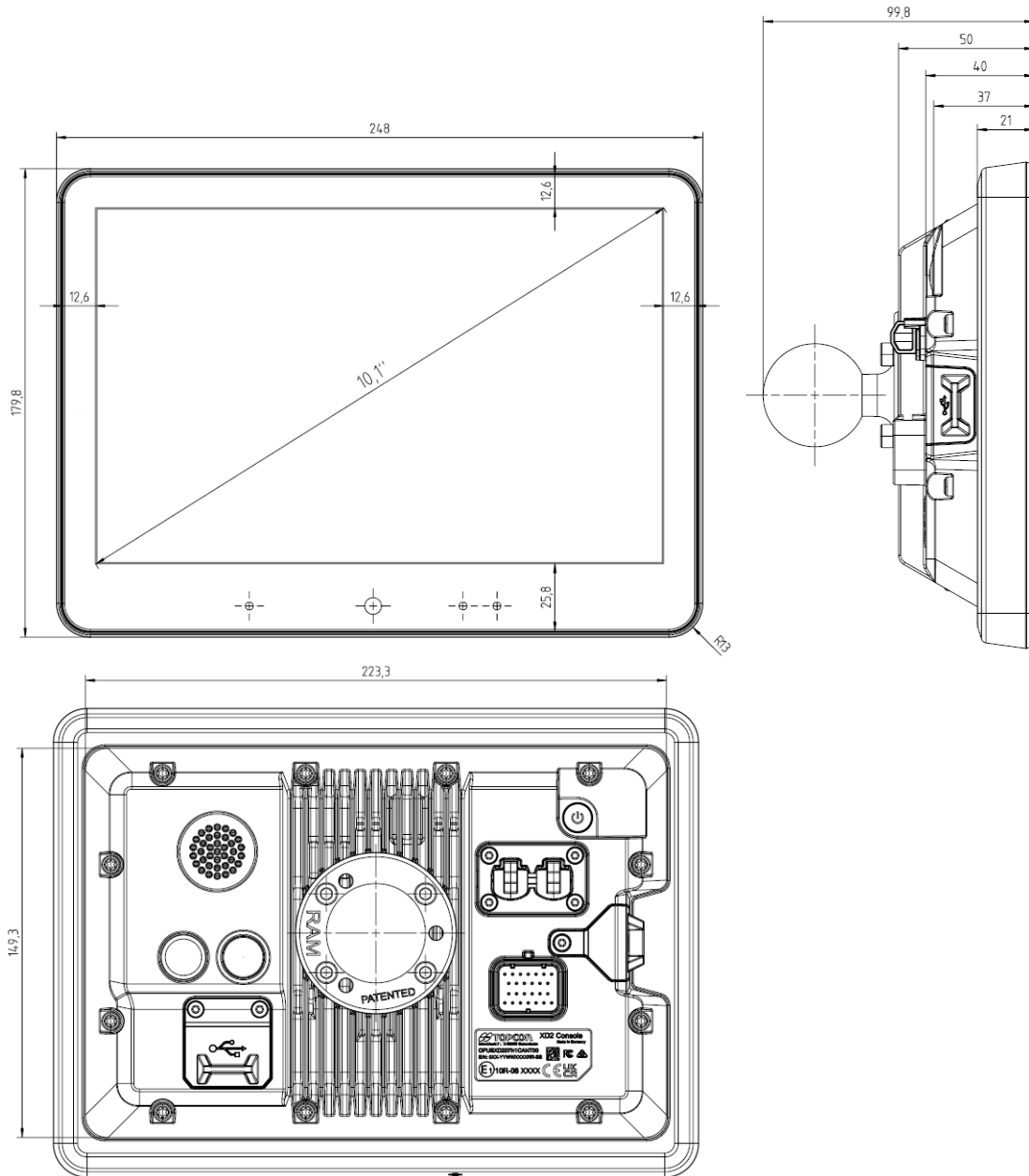

### Housing

Aluminium die cast  
 Powder coated

### Weight

1770g

### Mounting

- Landscape or portrait
- Standalone

## Dimensions 12.1" (OPUSC12\*)

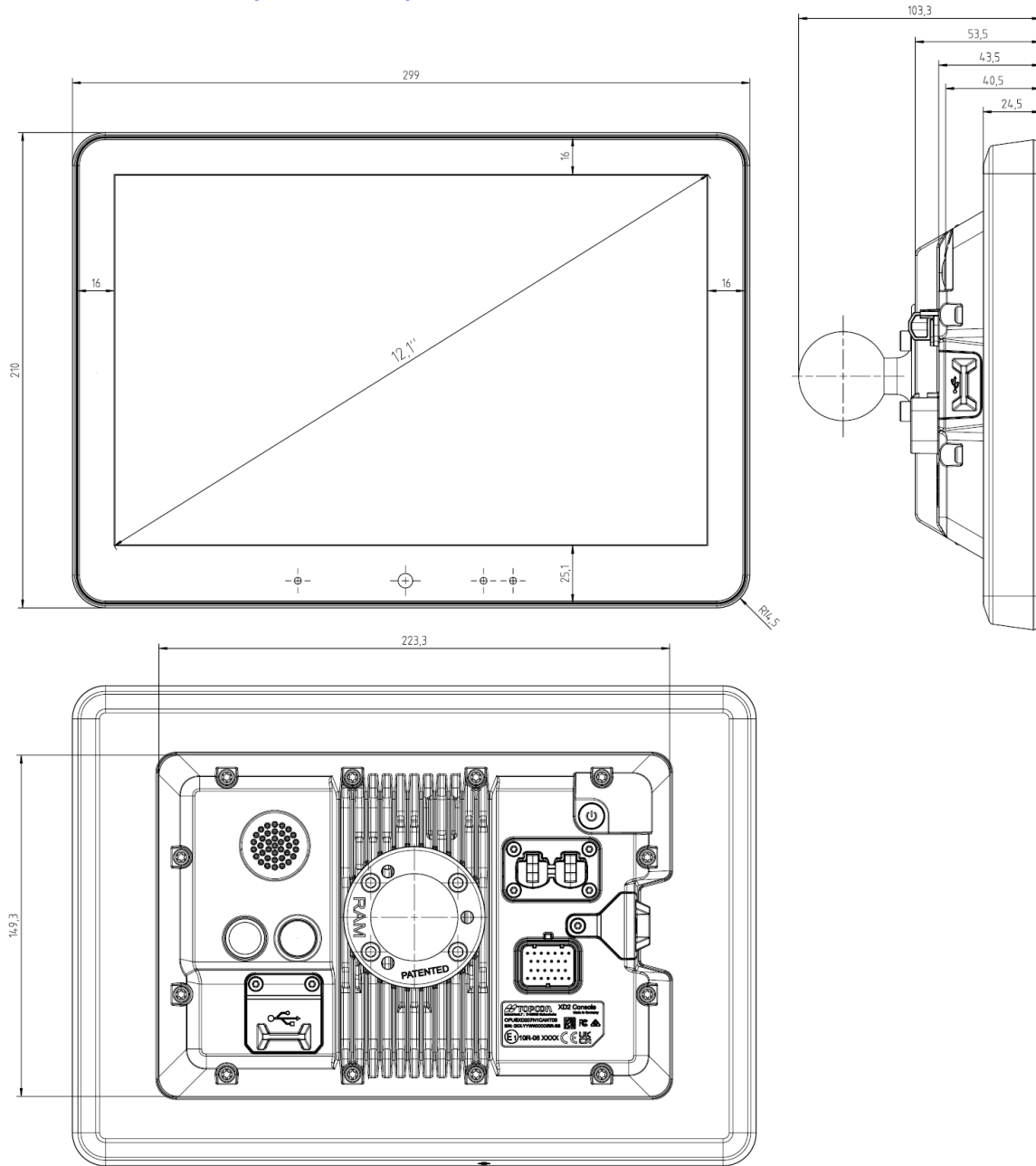

### Housing

Aluminium die cast  
 Powder coated

### Weight

2605g

### Mounting

- Landscape or portrait
- Standalone

### 3 Display

	7"	10.1"	12.1"
Type:	TFT Color Graphic LCD with LED backlight		
Size:	152.4 mm (W) x 91.44 mm (H)	216.96 mm (W) x 135.60 mm (H)	261.12 mm (W) x 163.2 mm (H)
Resolution:	800 x 480 px (WVGA), 15:9	1280 x 800 px (WXGA), 16:10	1280 x 800 px (WXGA), 16:10
Colors:	16.7 Mio.		
Brightness:	typ. 800 cd/m <sup>2</sup>	typ. 900 cd/m <sup>2</sup>	typ. 1100 cd/m <sup>2</sup>
Contrast Ratio:	typ. 1000:1	typ. 800:1	typ. 1000:1

### 4 Input Devices

Touch	Capacitive Touch
Indicators and Sensors	Light sensor Proximity sensor Acceleration Sensor Microphone 1 Multicolor LED

### 5 Electronics

#### Processor platform

CPU:	i.MX 8QuadPlus
Coprocessor:	STM32H725AGI3
Mass storage:	10.6 GByte pSLC (minus space for OS & application)
RAM:	4 GByte LPDDR4
RTC:	Buffered by gold cap Buffered for 2 weeks at T <sub>ambient</sub> Deviation max. 1 s/day

Speaker	Up to 90 dB @ 10 cm distance (max. @ ~3kHz)
---------	---

Operating frequency range	840 Hz to 6kHz
---------------------------	----------------

#### Silent Wake-Input

Input which can be used for Silent-Wake-On of the C-Series to reduce visible boot-time

Current consumption (without external load), max  
Low-power mode current depends on configuration

Power Mode	Current at 13,5 V DC	Current At 27 V
On (7")	1.0 A	0.6 A
On (10.1")	1.3 A	0.7 A
On (12.1")	2.0 A	1.1 A
Low-power	480 mA	260 mA
Sleep	180 mA	95 mA
Off	8 mA	7 mA

## Power supply

System supplied through terminal 30 (battery +, see pinout) and 31 (battery -, see pinout).  
Terminal 15 (ignition) to be used to switch on/off.  
Operating voltage range: 9 ... 36 V DC.  
Short circuit protection.  
Over-voltage protection up to 48 V for max. 5 min.  
Inverse polarity protection up to -48 V DC for max. 5 min.

## 6 Interfaces

### CAN Bus

3 x CAN-Interface according to ISO 11898,  
CAN-specification 2.0 B active, up to 1 Mbit/s  
(default 250 Kbit/s, possible 10Kbit/s, 20Kbit/s,  
50Kbit/s, 83.3Kbit/s, 111.1Kbit/s, 250Kbit/s,  
500Kbit/s, 800Kbit/s, 1 Mbit/s)  
All interfaces are CAN-FD tolerant

---

### RS232

2 x RS232-Interface  
Type: EIA232 (only RXD, TXD, GND)  
Speed: max. 256.000 Kbps

---

### USB

Side connector: 1 x Type C Super Speed  
5 Gbit/s  
Guaranteed 1.5A @ 5V  
Back connector: 1 x Type A High speed  
480 Mbit/s  
Guaranteed 1.5A @ 5V

---

### Ethernet-Interface

2 x 100Base-T1 Automotive ethernet  
Supply output at each Ethernet channel 500mA @  
12VDC guaranteed

### Inputs

4x configurable digital/frequency inputs  
- Input impedance > 10k Ohm  
- Frequency up to 10 kHz  
1x analog voltage input  
- Input impedance > 100k Ohm  
- Resolution: 10 bit  
- Voltage range: 0 ... 10 V

Over-voltage protection: Up to 36 VDC  
Short circuit protection: Up to 36 VDC

---

### Outputs

3 digital Low-Side outputs (switches to GND)  
- I<sub>max</sub> 300 mA open drain  
- R<sub>DS,on</sub> < 1 Ohm  
- R<sub>DS,off</sub> > 100 kOhm  
1 digital High-Side output (switches to VBat)  
- I<sub>max</sub> 500 mA  
- Short circuit protection: up to 36 V  
1 frequency Low-Side output (switches to GND)  
- I<sub>max</sub> 500mA open drain  
- Maximum switching frequency 10 kHz

## 7 Connectors

### Connectors

<b>Main</b>	Typo-AMP 1437288-6  Mating connector (customer) Typo-AMP 3-1437290-7  Mating crimp contact (customer) Typo-AMP 3-1447221-4  Mating crimp contact for power supply pins KL30 (Pin 1) and KL31 (Pin 3) (customer) Typo-AMP 3-1447221-3  Dummy Plug (customer) Typo-AMP 4-1437284-3
<b>Ethernet- Connector</b>	Rosenberger-HSD D4S24D-400A5 4-pole, Z-coded
<b>Side USB</b>	USB-Type C
<b>Back USB</b>	USB-Type A

## 8 Software

<b>Operating System</b>	Linux Kernel 6.1.1 or higher (NXP Release)
<b>Application Programming</b>	<ul style="list-style-type: none"><li>• Topcon Projektor Tool</li><li>• CODESYS 3.x</li><li>• C/C++</li><li>• ISO-UT Horizon</li></ul>

## 9 Testing and Verification

### CE-Compliance

EU Directive 2014/30/EU (EMC) according to

- EN ISO 14982: Agricultural and forestry machinery – Electromagnetic compatibility – Test methods and acceptance criteria

---

#### EMC Emission radiated

30-75 MHz	62-52 <sup>1</sup> dB(μV/m) – QP – 120kHz
	52-42 <sup>1</sup> dB(μV/m) – AV – 120kHz
75-400 MHz	52-63 <sup>2</sup> dB(μV/m) – QP – 120kHz
	42-53 <sup>2</sup> dB(μV/m) – AV – 120kHz
400-1000 MHz	63 dB(μV/m) – QP – 120kHz
	53 dB(μV/m) – AV – 120kHz
1000-2500 MHz	73 dB(μV/m) – P – 120kHz
	53 dB(μV/m) – AV – 120kHz
2500-6000 MHz	80 dB(μV/m) – P – 1000kHz
	60 dB(μV/m) – AV – 1000kHz

QP: Quasi-Peak

AV: Average

P: Peak

1: Value decreases linearly with the logarithm of the frequency.

2: Value increases linearly with the logarithm of the frequency.

#### EMC Immunity radiated

20MHz to 800MHz with amplitude modulation 800MHz to 6GHz with pulse modulation.

30V/m for the radiated field (absorber lined chamber) testing method (ISO 11452-2) in vertical and horizontal polarization.

OR/AND

60mA for the Bulk Current Injection (BCI) testing method (ISO 11452-4)

## EMC Emission conducted

	<b>12V-System</b> (Maximum values)	<b>24V-System</b> (Maximum values)
	Positive slow pulses: +25V	Positive slow pulses: +25V
	Negative slow pulses: -50V	Negative slow pulses: -100V
	Positive fast pulses: +50V	Positive fast pulses: +100V
	Negative fast pulses: -75V	Negative fast pulses: -100V
	<b>12 V-System</b>	<b>24 V- System</b>
Test Pulse 1	Us = 112 V; FS: C	Us=-450V; FS: C
Test Pulse 2a	Us=+55V; FS: B	Us=+55V; FS: B
Test Pulse 2b	Us=+10V; FS: C	Us=+20V; FS: C
Test Pulse 3a	Us=-165V; FS: A	Us=-220V; FS: A
Test Pulse 3b	Us=+112V; FS: A	Us=+220V; FS: A
Test Pulse 4	Us <sub>6</sub> =6V; Us=6.5 V FS: B	Us <sub>6</sub> =6V; Us=10V FS: B
(Starting profile)		
Load Dump	Us=+79V; FS: C	Us=+151V; FS: C

FS: Function Status

## Electrostatic Discharge

+/- 8kV contact discharge; FS: A

+/- 15kV air discharge; FS: A

### E1 – Type approval

EU Directive ECE R 10.6

### Protection Level (IP Code)

IP 6k6 according to ISO 20653: Road Vehicles – Degrees of protection (IP-Code) – Protection of electrical equipment against foreign objects, water and access

### Electrical

12 and 24V-Systems according to:

#### Inverse Polarity resistance

5min @ -48V (no defect)

#### Over voltage resistance

5min @ +48V (no defect)

#### Short circuit strength

Connect each Pin of Main-, Video- and Ethernet-Connector for 5 Min to GND and for 5 Min to 36V; FS: C

#### De-/Increase Supply Voltage

Sweep Voltage UMin-0V-UMin with 0.5V/min; FS: D

### Drop in Supply Voltage

#### 12 V System

#### 24 V System

UStart=UMin; US=4.5V  
 td=100ms; FS: B

UStart=UMin; US=9V  
 td=100ms; FS: B

### Battery less Operation

#### 12 V System

#### 24 V System

U1=10V; U2=18V;  
 t=5min; FS: A

U1=20V; U2=38V;  
 t=5min; FS: A

## Mechanical

### Vibration, noise

Frequency [Hz]	PSD [(m/s <sup>2</sup> )/Hz]
10	18
20	36
30	36
141	1.69
200	2
300	1
2000	1

32h per Axis; FS: A

### Vibration, sinusoidal

Resonance sweep

Frequency	Displacement	Acceleration
10 Hz	-	1 g
2000 Hz	-	1 g

0,1 Octave/minute, 30min per resonance

### Endurance Test:

Frequency	Displacement	Acceleration
10 Hz	-	5 g
2000 Hz	-	5 g

0.5 Octave/minute, 8 h per resonance. FS: A

### Mechanical shock

Part 1: 300m/s<sup>2</sup>, 18ms, 3 times per axis/direction; FS: A

Part 2: 500m/s<sup>2</sup>, 6ms, 10 times per axis/direction; FS: A

Part 3: 400m/s<sup>2</sup>, 6ms, 4000 times per axis/direction; FS: A

### Drop Test

Drop the DUT on each side and each edge from a high of 1m on a concrete floor.  
 No damage or visible damage.

### Package

Drop Test

Drop the DUT inside the package on each side and each edge from a high of 1m on a concrete floor.  
 No damage of the DUT  
 No cracks to the package

### Climate

#### Salt spray resistance

Part 1:

7 cycles at 24h (8h spraying; 16h rest)  
 salt concentration: 5%

Part 2:

4 cycles at 168h; 4 cycle:

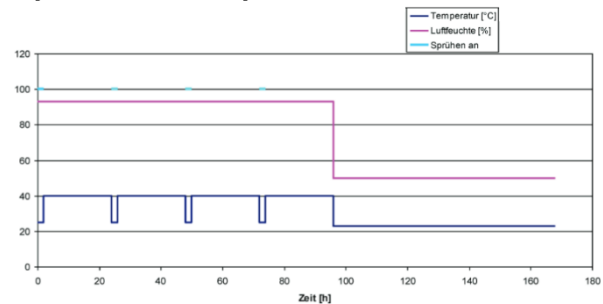

#### Chemical resistance

Apply once a day, for three days, the following chemicals with a brush over the exposed surface. Inspect without rinsing immediately after-wards and after 100h.  
 Brake fluid, Antifreeze liquid (Ethyl-glycol), Diesel oil, Domestic Ammonia, Gasoline, Hydraulic oil 10W40, Liquid lime, Motor oil, NPK Chemical fertilizers 20 10 20, Windscreen cleaning mixture, Ammonium Nitrate and Ammonium Phosphate fertilizers, Bovine Effluent - (up to 5% propionic acid), Diesel fuel, STOU (Super Tractor Universal Oil) lubricating oil.

#### Damp heat steady

10days @+40°C and 93%r.H.; FS: C

#### Damp heat cyclic

6 cycles (each 24h); TLow=+25°C; THigh=+55°C  
 Humidity: >= 90%r.H.; FS: A

#### Operating temperature

24h @ -30°C; FS: A  
 96h @ +75°C; FS: A

#### Storage temperature

24h @ -30°C; FS: C  
 48h @ +80°C; FS: C

#### Temperature cycling

3 cycles (each 8h); TLow=-30°C; THigh=+70°C; FS: A

#### Temperature shock

10 cycles (each 2h); TLow=-30°C; THigh=+70°C; Tchange: <30s; FS: A

#### UV resistance

Over-all time: 1500h  
 Cycle: 8h UV at +60°C, 4h 95%r.H.

No material damage, No visible change

## 10 Pinout

Main connector pinout

Pin No.	Assignment	Description
1	KL30	supply voltage +; terminal 30
2	KL15	ignition input; terminal 15
3	KL31	supply voltage -; terminal 31
4	Wake_In	Wake Input, "Doorswitch"
5	Freq_Out	Frequency Output
6	D_IN_4	Digital Input 4 / Frequency Input 4
7	D_OUT_H	Digital Highside Output
8	CAN1H	CAN 1 high
9	CAN1L	CAN 1 low
10	CAN2H	CAN 2 high
11	CAN2L	CAN 2 low
12	CAN3H	CAN 3 high
13	CAN3L	CAN 3 low
14	RS232_RxD2	RS232-2 – Receive Data input
15	RS232_TxD2	RS232-2 – Transmit Data output
16	RS232_RxD1	RS232-1 – Receive Data input
17	RS232_TxD1	RS232-1 – Transmit Data output
18	RS232_GND	RS232 GND
19	D_IN_1	Digital Input 1 / Frequency Input 1
20	A_IN	Analog Input
21	D_OUT_L1	Digital Output Lowside 1
22	D_OUT_L2	Digital Output Lowside 2
23	SERV_EN	Service enable
24	D_OUT_L3	Digital Output Lowside 3
25	D_IN_2	Digital Input 2 / Frequency Input 2
26	D_IN_3	Digital Input 3 / Frequency Input 3

View on rear side of the OPUS-C console

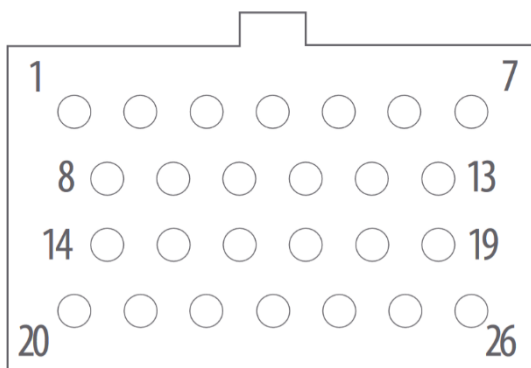

Automotive Ethernet connector pinout

<b>100Base-T1 Rosenberger HSD, Z-Coded, 4pin</b>	
<b>1</b>	D+
<b>2</b>	12V Power supply
<b>3</b>	D-
<b>4</b>	Power GND

View on rear side of the OPUS-C console

