

## Operating Manual

# EC Motor

**Model: EM13210A312XX**

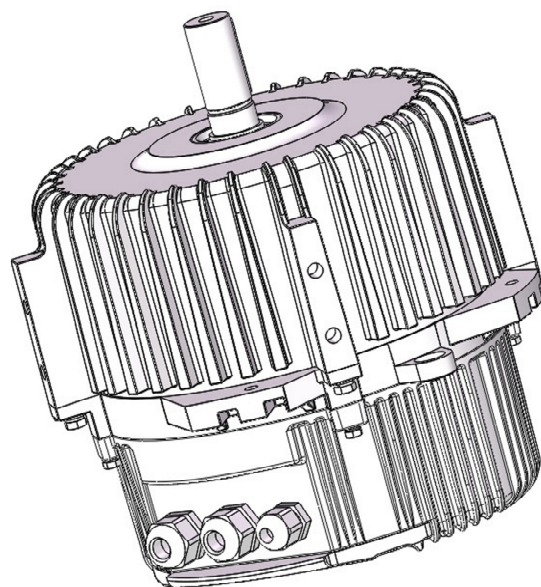

Document number: 210017  
Document version: 01  
Release date: 22-02-2023

---

---

The manufacturer retains the right to change the contents of this document without prior notice. Reproduction by any means whatsoever in whole or in part, is strictly forbidden. All rights reserved.

---

## 1 INTENDED USE

The “**EC Fan**”, model “**EC 132**” is an integrated Electric Commutated Permanent Magnet motor (EC/PM) with a fully integrated Variable Speed drive (VSD). Hereinafter called: “EC motor”.

The EC motor is designed for use in dedicated axial fan systems. It has features like Spin start, Skip frequencies, Low temperature start, Auto restart, etc. Furthermore it is equipped with various safety and protection functions like, Rotor Locked detection, Phase failure detection, Over current protection, Over and Under voltage protection, etc. This Operating Manual only describes the functional use and operation of the VSD part. Please refer to other documentation with regard to mechanical installation of the EC motor.

## 2 SAFETY INSTRUCTIONS

Read this operating manual carefully before starting to work on the device. Observe the following warnings to prevent malfunctions or danger to persons.

### 2.1 Warning symbols in this manual

The following warning levels and symbols are used in the manual



<b>CAUTION!</b>	Indicates a potential hazardous situation. Failure to follow these instructions can result in malfunction or damage to the equipment.
-----------------	---



<b>DANGER!</b>	Indicates an immediate dangerous situation, risk of electric shock. Failure to follow these instructions can result in serious injury or death to the user in addition to serious damage to the equipment.
----------------	--



<b>HOT SURFACE!</b>	Failure to follow these instructions can result in injury to the user.
---------------------	--



<b>NOTE!</b>	Important additional information and advice for the user.
--------------	---

### 2.2 Qualified users

Only qualified and trained technical specialists are permitted to install, test and perform work on the equipment.

### 2.3 Opening the unit

Always take adequate precautions before opening the AC drive. Although the connections for the control signals and the switches are isolated from the main voltage, do not touch the control or power terminals when the unit is switched on.



<b>DANGER!</b>	Always switch off the mains voltage before opening the unit and wait at least 3 minutes to allow the capacitors to discharge.
----------------	---

### 2.4 Earthing

The AC drive must always be earthed via the mains safety earth connection. The protective earthing conductor shall comply with the local safety regulations for high protective earthing conductor current equipment.

### 2.5 Residual current device (RCD) compatibility

This product cause a DC current in the protective conductor. Where a residual current device (RCD) is used for protection in case of direct or indirect contact, only a Type B RCD is allowed on the supply side of this product. Use RCD of 300 mA minimum.

---

## 2.6 Voltage tests (megger)

**CAUTION!**

Do not carry out voltage tests (Megger) on the unit, it will permanently damage the internal electronic components

## 2.7 Alarms

Never disregard an alarm. Always check and remedy the cause of an alarm.

## 2.8 DC-link residual voltage

**DANGER!**

After switching off the mains supply, dangerous voltage can still be present in the AC drive. When opening the AC drive for installing and/or commissioning activities wait at least 3 minutes. In case of malfunction a qualified technician should check the DC-link or wait for one hour before dismantling the AC drive for repair.

## 2.9 Heat Warning

**HOT SURFACE!**

Be aware of that the housing of the unit is used as heat sink and therefore can have high temperature.

## 3 STANDARDS

The equipment complies to the following international standards.

IEC 60034-1	Rotating Electrical Machines Part 1
IEC 60364-1	Electrical Installations
EN60204-1	Machinery Directive
EN 50598/2	Efficiency Classes for Power Drive Systems

---

## 4 MECHANICAL DATA

### 4.1 Dimensions

All dimensions in mm

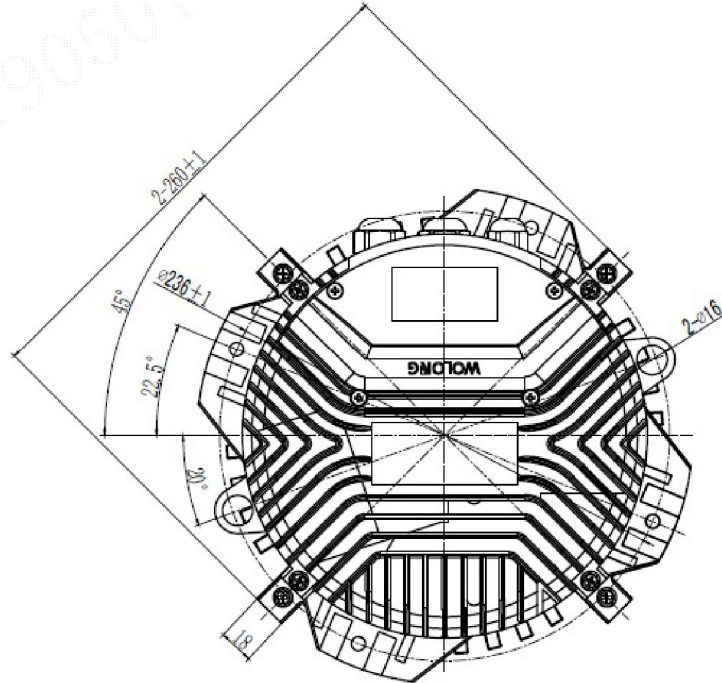

Figure 1 Dimensions main view

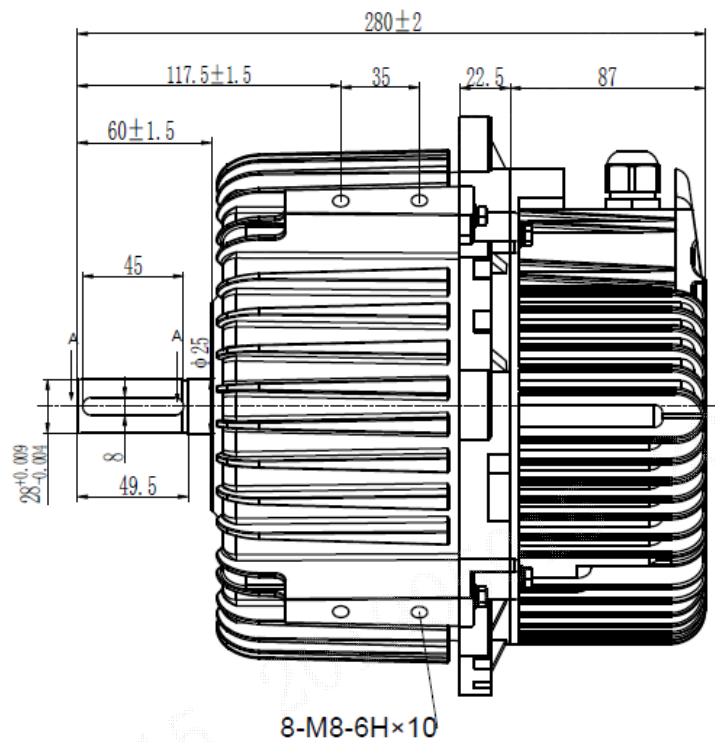

Figure 2 Dimensions side view

## 4.2 Views

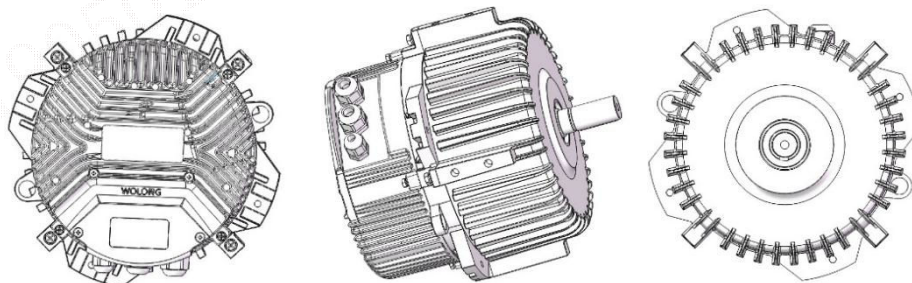

Figure 3 Views

## 4.3 General Data

<b>Weight</b>	17.0kg
<b>Housing</b>	Die-cast aluminum
<b>Dimensions HxWxD</b>	260 x 260 x 280 mm
<b>Direction of rotation</b>	Counter-Clockwise, viewed toward shaft
<b>Degree of protection</b>	IP55
<b>Mounting</b>	IM B30 IM B10
<b>Insulation class</b>	F
<b>Ambient Temperature</b>	-25°C ~ +55°C, when placed in an air stream of >9m/s

## 4.4 Transport and storage conditions

Use the device in accordance with its protection type.

<b>Max. permissible ambient motor temp. (transp./ storage)</b>	+80°C
<b>Min. permissible ambient motor temp. (transp./storage)</b>	-40°C

## 5 ELECTRICAL DATA

### 5.1 Nominal Ratings

Motor	EC/PM Electrical Commutated Permanent Magnet
Pole #	10 pole
Phase	3
Efficiency Class	IE4
Power	1.5 kW
Nominal Power factor	0.90
Nominal voltage	400 VAC
Input voltage range	380 ~ 480 VAC +/- 10%
Motor current	3.0 ~ 2.4 A
Frequency	50/60Hz
Output Switching frequency	10 kHz
Speed range	200 ~ 750 rpm
Maximum speed	750 rpm
Duty	S1
Maximum Shaft Torque	19.1 Nm

### 5.2 Electrical specification

Control signal inputs and outputs:

ANALOG INPUTS	
Input voltage /current	0 - 10V and 4-20mA via Analog input
Maximum input voltage/current	28V /30mA
Input impedance	54 kOhm (voltage) 249 Ohm (current)
Voltage input PWM	PWM pulse 1-10kHz with duty cycle from 5%-100%
Resolution	12 bit, 2.63mV (0-10V) / 5.32µA (0-20mA) / 6.80µA (4-20mA)
Hardware accuracy	1%
ANALOG OUTPUTS	
Output voltage /current	0 - 10V
Maximum output	10V /10mA
Short circuit current	32 mA
Resolution	10 bit – 9.77mV
Maximum load impedance	1 kOhm
Hardware accuracy	1%
DIGITAL INPUTS	
Input voltage	High: >5-28VDC Low: < 1VDC
Max Input voltage	+28VDC
Input impedance	2.2 kOhm
Signal delay	52 ms
RELAY	
Contacts	0.1 – 2 A/Vmax 250 VAC or 42 VDC for general Purpose or Resistive use only
AUXILIARY SUPPLY	
+10V out	+10 VDC @10 mA Short-circuit current +30 mA max
+24V out	+24 VDC Short-circuit current, 50 mA max (together with Digital Outputs)

### 5.3 Control Function

---

The default mode is 0-10V. You can switch to MODBUS mode using PC-tool. If you want to return to 0-10V mode, just cut off the power supply of the motor and then re-power it.

The default mode is 0-10V. You can switch to MODBUS mode using PC tools. Please note that after the motor is powered off and re-energized, the motor is still in MODBUS mode. If you want to switch to the default 0-10V mode, you need to modify the speed adjustment mode in the PC tool interface.

The default mode is MODBUS mode (at this time, if 0-10V signal is provided to the motor, the motor will not be affected by the command signal). You can use PC tools to switch to 0-10V mode. If you want to return to MODBUS mode, just cut off the power supply of the motor and then re-energize it.

The default mode is MODBUS (at this time, if 0-10V signal is provided to the motor, the motor will not be affected by the command signal). You can use PC tools to switch to 0-10V mode. Please note that after the motor is powered off and re-energized, the motor will remain in 0-10V mode. If you want to switch to the default MODBUS mode, you need to modify the speed adjustment mode in the PC tool interface

### 5.3 Main Mechanical Parts

No.	Part Name	Material	Remark
1	Front cap	Aluminum	ADC12
2	Rear cap	Aluminum	ADC12
3	Rotor core	Silicon Steel	DW470-50
4	Magnet	NdFeB	IPM
5	Shaft	Steel	45#
6	Bearing	Steel	6205/6205ZZ NSK ENS
7	Wave Spring	Steel	65Mn
8	Stator core	Silicon Steel	DW470-50
9	Winding	Polyurethane copper wire	QZY-2/180°C
10	PCB housing	Aluminum	ADC12
11	PCB	FR-4	

## 6 ELECTRICAL CONNECTIONS

### 6.1 Overview electrical connections

Number	Name	Function
①	L1	Power input phase 1
	L2	Power input phase 2
	L3	Power input phase 3
	PE	Protective grounding
②	COM	Fault output interface, normally open contact
	NO	
③	10v DC	Internal 10V DC voltage
④	A1	0-10V speed control input interface
⑤	D1	Motor start enable interface, high level start
⑥	D2	Steering conversion interface, high/low level switching
⑦	24v DC	Internal 24V DC voltage
⑧	485A	485 communication interface
	485B	
	485G	
⑨	U、V、W	Connect to the motor
⑩	GND	Reference place

Figure 4 Overview electric connections

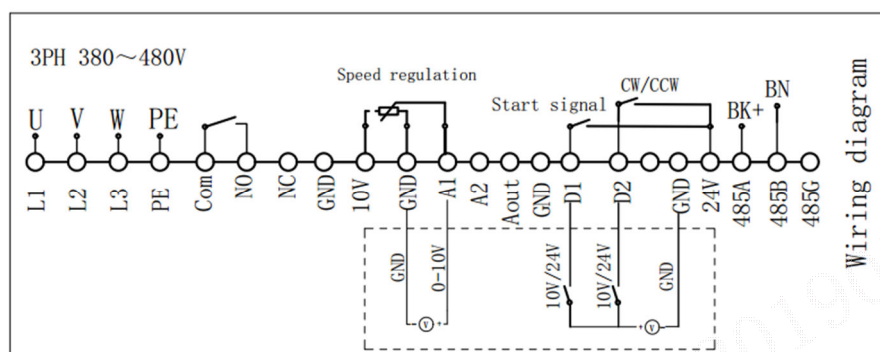

1. Inside the dashed box is the use of external signals to control the wiring method.
2. The upper part uses the internal signal of the controller to control the wiring method

Figure 5. Overview of electrical wiring

## 6.2 Fuses

To protect the 3 phase mains, according to IEC 60364, a maximum 16A gG fuse (acc. IEC60269) or a C16A automatic circuit breaker with similar characteristic must be used.



### NOTE!

Always check local legislation and regulations when defining the supply connection and line fuses in relation to the environment and ambient conditions.

## 6.3 Opening the terminal cover

Before opening the cover be aware that the unit has been safely disconnected from the mains supply, also be aware that the housing is cooled down.



### HOT SURFACE!

Be aware of that the housing of the unit is used as heat sink and therefore can have high temperature.



### DANGER!

After switching off the mains supply, dangerous voltage can still be present in the AC drive. When opening the AC drive for installing and/or commissioning activities wait at least 3 minutes. In case of malfunction a qualified technician should check the DC-link or wait for one hour before dismantling the AC drive for repair.

- 1) Remove the 4 screws as indicated; 4 pieces M4x8 mm

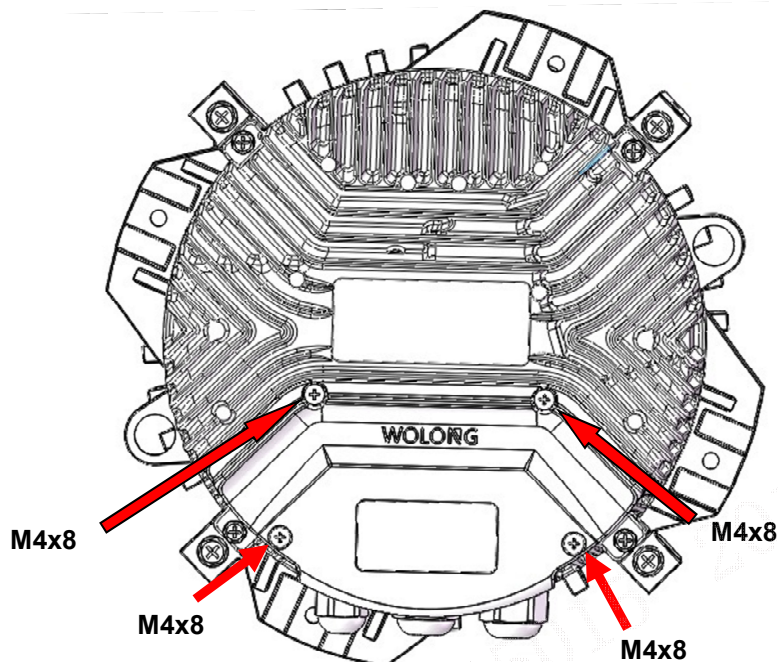

Figure 6 Remove the terminal cover

- 2) Open the cover to access the POWER and the CONTROL terminals

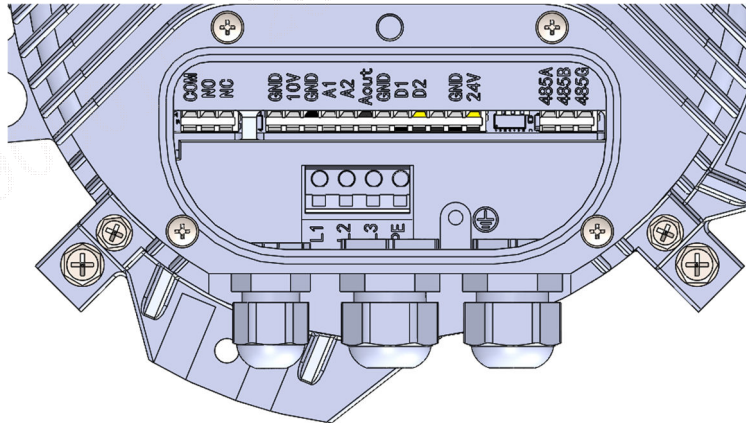

Figure 7 Cover removed

3) When closing the cover take care that the sealing is in the correct position and use a torque wrench to tighten the screws with a torque of 1.6 ~2.4 Nm

#### 6.4 Main supply connection

The terminals are all spring clip type and are made to use with or without ferrule. It is strongly advised to use ferrules, for a good and reliable connection.

- Massive or stranded wire: 2,5 mm<sup>2</sup>
- Stranded wire with ferrule: 2,5 mm<sup>2</sup>
- Stranded wire with isolated ferrule: 1,5 mm<sup>2</sup>

Name	Function
L1	Input phase 1
L2	Input phase 2
L3	Input phase 3
PE	Protective earth
PE SCREW	Protective earth on housing

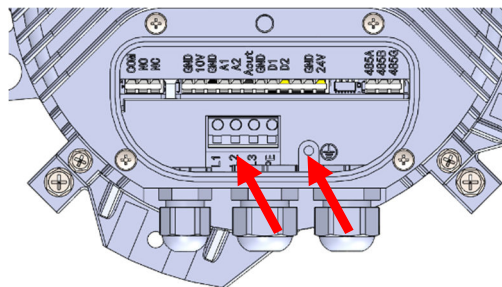

Figure 8 Power terminal and location PE screw with marking

Use the middle cable gland for the mains supply cable. And secure it with a strain relief by using the cable gland.



**NOTE!**

The mains supply cable can be a normal NON shielded cable. The EMC regulations do NOT demand a shielded input power cable. Armored cable can be used for mechanical protection if needed.

To maintain safety in case of damage to or disconnection of the protective earthing conductor in the PE terminal, and a touch current in the protective earthing conductor which can exceed 3,5mA AC. there is a PE SCREW implemented for the connection of a second protective earth conductor.



**DANGER!**

The touch current in the protective earthing conductor can exceed 3,5mA AC.



**NOTE!**

The minimum size of the protective earthing conductor shall comply with the local safety regulations for high protective earthing conductor current equipment.

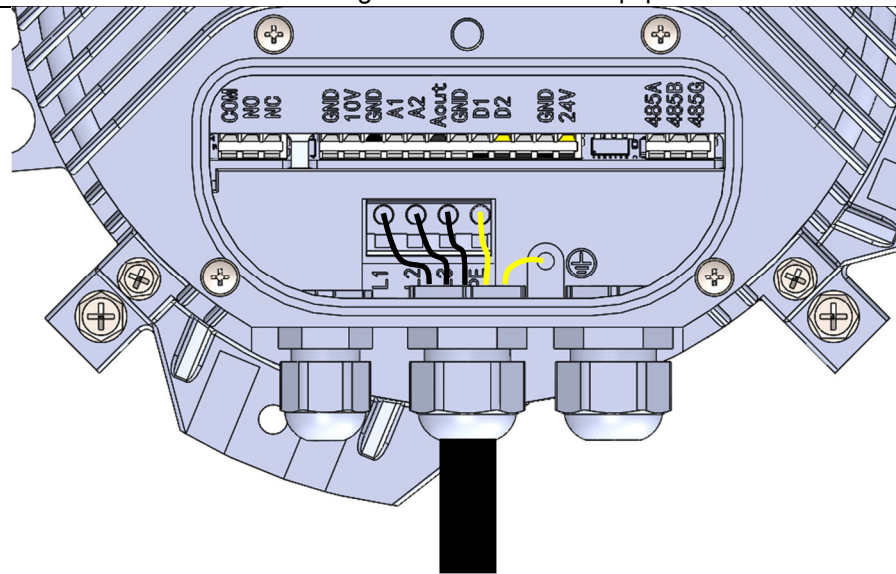

Figure 9 Mains cable connected

## 6.5 Control Connections RCTS (Remote Control Terminal Strip)

Name	Function	Default	Remarks
COM	Output Relay common contact	Fault (Trip)	Potential free contact
NO	Output relay N.O. contact		
NC	Output relay N.C. contact		
GND1	Signal ground	common	
+10V	+10 VDC auxiliary supply max 10mA		
GND1	Signal ground	common	
A1	Analog Input 1	Set reference 0-10 V	
A2	Analog Input 2	Set reference 4-20 mA	
AOut	Analog Output	Reserved output signal	Programmable output
D1	Digital Input 1	Motor start enable signal	Only used when using analog signal speed control 0v: Start Disable 10v: Start Enable
D2	Digital Input 2	Motor rotation direction control signal	Only used when using analog signal speed control: 0v: CW 10v: CCW
GND1	Signal ground	common	
+24V	+24 VDC Short-circuit current, 50 mA max		
485A	RS 485 data +	RS 485 serial port	Galvanic isolated
485B	RS 485 data -		
GND1	RS 485 ground		

## 6.6 RS485 Termination/Biasing DIP switches

The 4 dip switches S1 to S4 have the following functions:

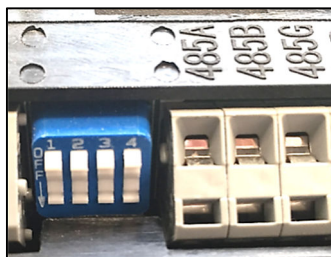

Figure 10 Default setting

S1	S2	S3	S4	function
OFF	OFF	OFF	OFF	NO Termination NO Biasing (default)
ON	ON	OFF	OFF	Terminated
OFF	ON	ON	ON	Terminated and Biased
OFF	OFF	ON	ON	Biased

### 6.6.1 Termination

A properly selected RS485 bus uses a cable with a characteristic impedance of 120Ω. To minimize transmission line effects such as reflection the bus needs at the far-ends to be terminated with 120Ω. An optimal RS485 bus uses a topology where the far-end nodes are interconnected with a two line twisted pair cable. All other nodes are connected to the same twisted pair cable where the stubs are as short as possible. In practice the topology for RS485 wiring should be a chain of nodes with limited stub lengths preferably shorter as 3 meter.

### 6.6.2 Fail safe biasing

A RS485 receiver must detect a logic 1 or 0 depending on the difference of the A to B voltage. A small zone is undefined and can generate a 1 or a 0 for a positive or negative difference of e.g. 100mV. The RS485 standard states an undefined output at maximum difference of up to +/- 200mV. An undriven bus has a difference close to 0 volt which can cause side effects which disturb proper communication. The biasing fail safe circuitry takes care that at open bus the input difference is always more as 250mV. This

value is based on the previously mentioned 200mV plus an additional 50mV noise margin. Every AC drive has such on-board fail safe biasing circuitry. On an RS485 bus however only one such circuit should be activated. In general, this is done at one of the far-ends of the bus.

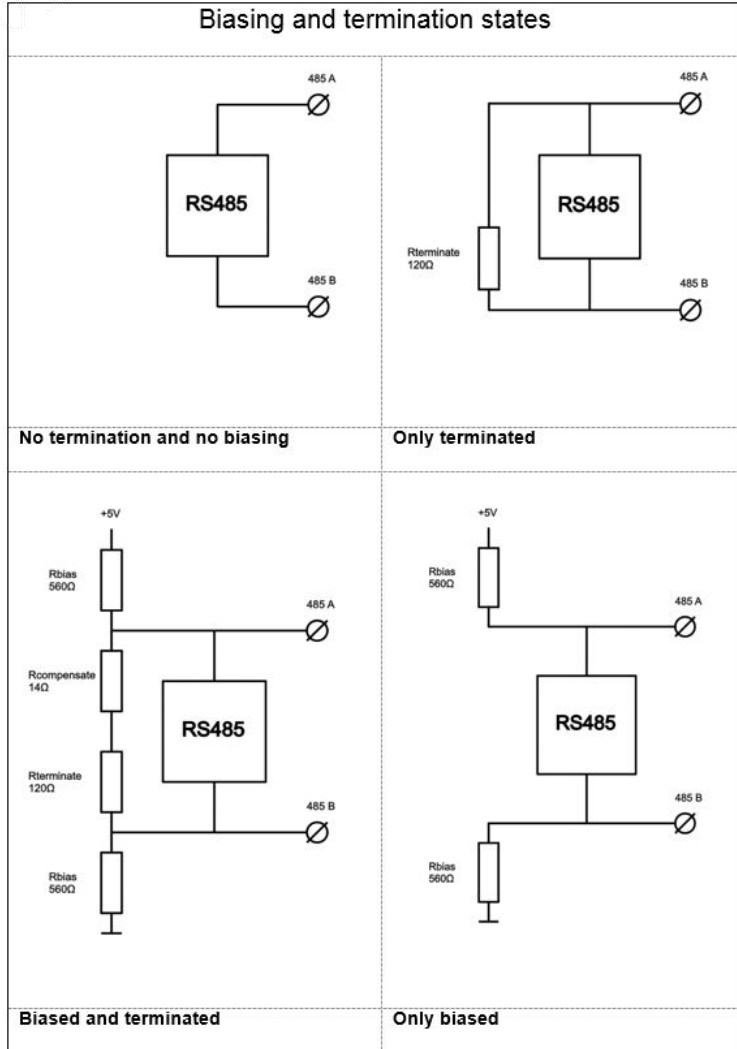

Figure 11 Termination and Biasing

## 6.7 Terminal strip RCTS layout

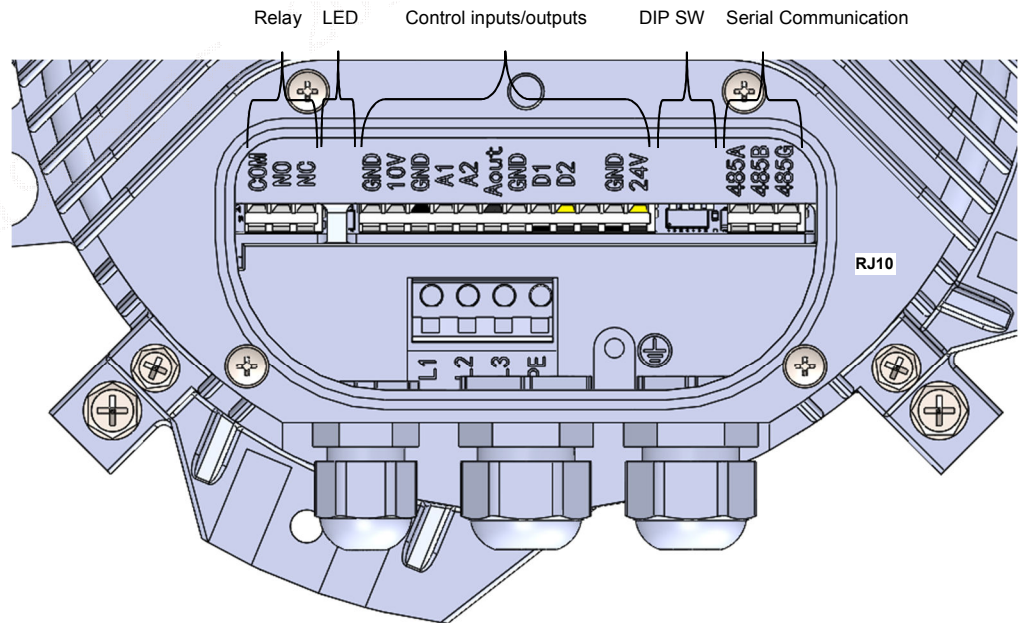

Figure 12 Remote Control Terminal Strip RCTS

## 6.8 EMC cable gland for control and communication cables

For all control signals including the serial communication ports there is a special EMC gland fitted which can fit maximum 3 cables with EMC screening. The screens of the cables must be connected inside the gland and not to PE connections.

The figure below shows the 0~10V speed control wiring diagram. Among them, D1 needs to be connected to the high level, that is, 10V and D1 are short-circuited; A1 needs to have 0~10V analog voltage input.



### NOTE!

For all control signals including the serial communication ports it is mandatory to use the special EMC cable gland, to fulfil the EMC regulations.

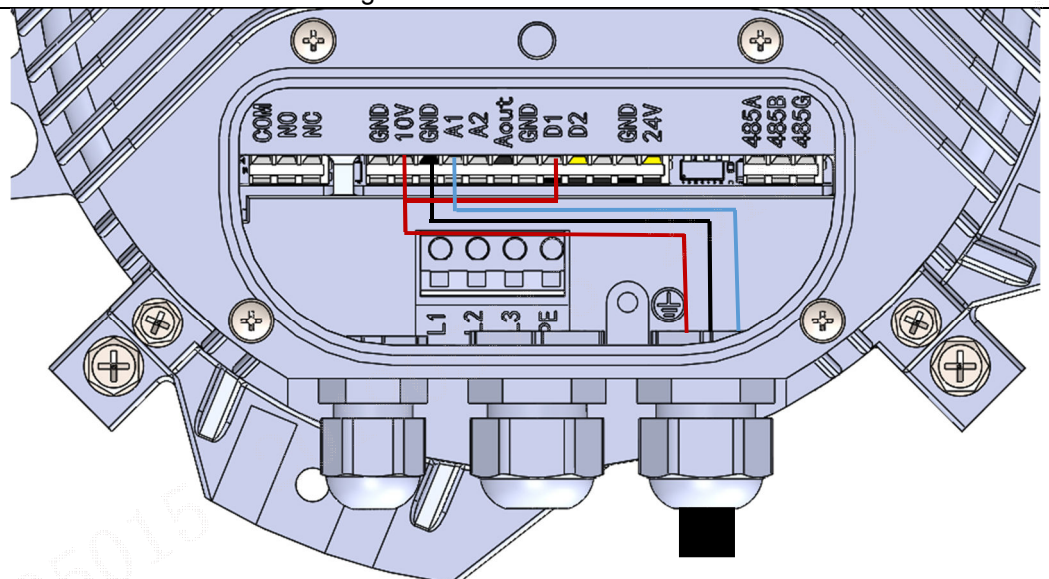



Figure 13 ~~EMC cable connection setting~~

### 6.9 Output relay connection

For the relay cable it is NOT necessary to use screened EMC cable.

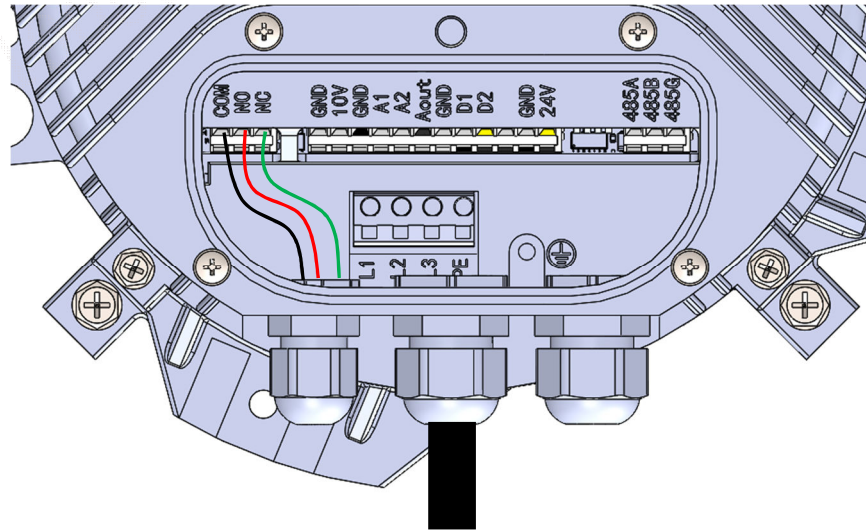
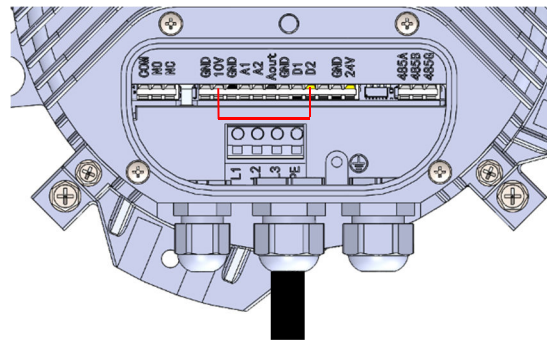

Figure 14 Relay cable connection

### 6.10 Motor rotation direction setting



**NOTE!**

Only used when using analog signal speed control.  
The direction of rotation of the motor must be set while the motor is stopped.

1. When the D2 terminal is left floating, the direction of rotation of the motor is CW.
2. When the D2 terminal is connected to the 10v analog signal, the motor rotates in the CCW direction- As shown in **Figure 14**.

## 7 PARAMETER SELECTION AND SETUP

The control Parameters can only be set with help of the WOLONG EC Technology Control Software. This PC tool is described in chapter 9

### 7.1 Parameter Groups functions

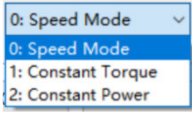
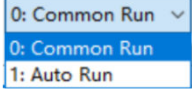
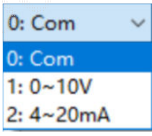
Group	Parameter name	Read / Write	Note
G0	Control		
	Maximum speed	r/w	The max speed the motor can reach
	Speed setpoint	r/w	The speed you want the motor to run
	Rotation direction	r/w	The direction you want the motor to run
	Control mode	r/w	Divided into three:  Speed mode: constant speed control Constant torque: constant torque control Constant power: constant power control
	Auto run	r/w	Divided into two:  Common run: set the speed by pc tool to let the motor run Auto run: the auto run speed is set with parameter 'Auto speed level 1' or 'Auto speed level 2'
	Auto speed level 1	r/w	The first type of auto running speed level
	Auto speed level 2	r/w	The second type of auto running speed level
	Toque setpoint	r/w	When you choose the control mode with "constant torque", you should set this torque value.
	Command from	r/w	Divided into three:  Com: Modbus communication by pc tool 0-10V: 0-10 v external voltage input

			4-20ma: 4-20ma external current input
	Frequency hopping	r/w	Frequency hopping point to avoid resonance, if you set the Frequency hopping with 700rpm, then the motor will run below 670rpm or above 730rpm
	Speed acceleration	r/w	Speed acceleration every second
	Torque acceleration	r/w	Torque acceleration every second
	Speed_kp_w1	r/w	The kp of speed
	Speed_ki_w1	r/w	The ki of speed
G10	Fan Serial No.	r/w	Fan serial number, parameters can be stored
	Motor Serial No.	r/w	Motor serial number, parameters can be stored
	Parameter backup	r/w	Parameter can be backuped
G20	Motor Monitor		
	Motor speed	r	Motor running speed
	Motor current	r	Motor running current
	Motor power	r	Motor running power
	Motor torque	r	Motor running torque
	Motor Id current	r	Motor running Id current
	Motor Iq current	r	Motor running Iq current
	Motor voltage	r	Motor running bus voltage
G30	State Monitor		
	Err state	r	Motor running error state
	Running time	r	Motor running time
	SH version	r	Motor software and hardware version
	Ntc temperature	r	NTC temperature
	Modbus address	r/w	Slave address

---

## 8 LED INDICATIONS

On the Terminal strip (RCTS) there are two LED indications, which give information on the status of the drive.

INDICATION	STATUS
GREEN BLINKING	Hart beat of the processor OK
RED BLINKING	Warning active, no TRIP
RED CONTINUOUS ON	ERROR, unit is tripped
RED OFF	Normal healthy operation

The location of the LEDs are between the relay contacts and the I/O terminals

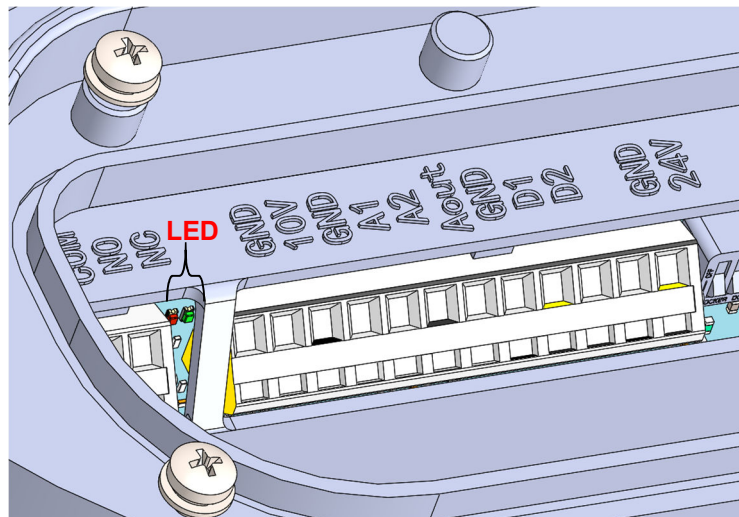

Figure 16 LED position

## 9 CONTROL SOFTWARE " F132-PC-TOOL "

The WOLONG EC Technology Control Software is needed to READ and WRITE the parameters. It is possible to export a parameter file from the unit and write a file into the unit.

- In this instructions we use units which are set to the factory default address 1
- Connect the PC or laptop to communication ports
- Click on the icon of the program, this is an executable file and will not be installed in operating system of the computer.

### 9.1 Make a RS485 connection

#### 1) Connect to the Bus

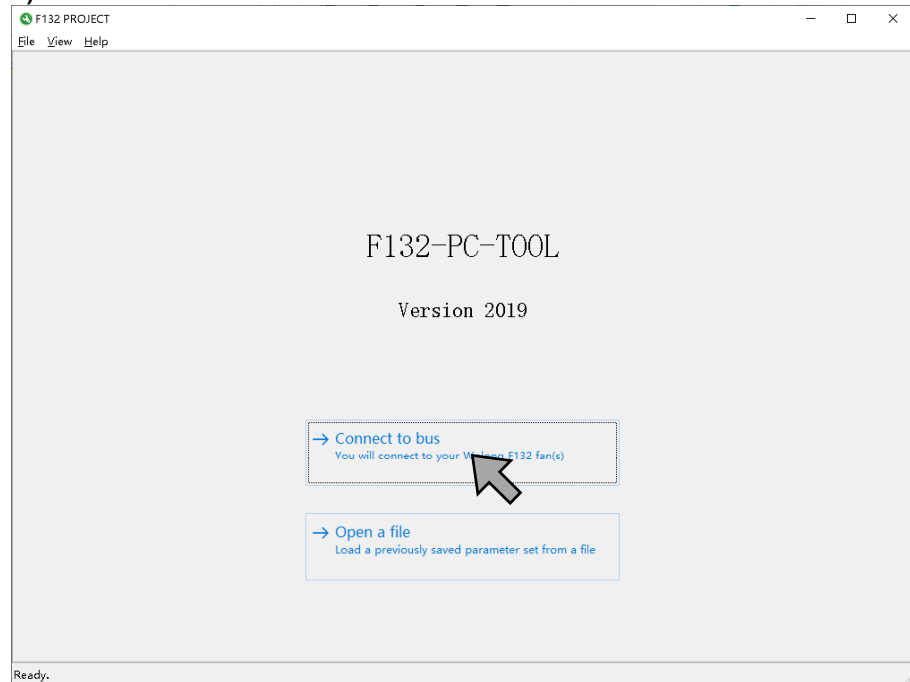

ecm-software

#### 2) RS485: Select the Com port, set parity bit to EVEN PARITY (default)

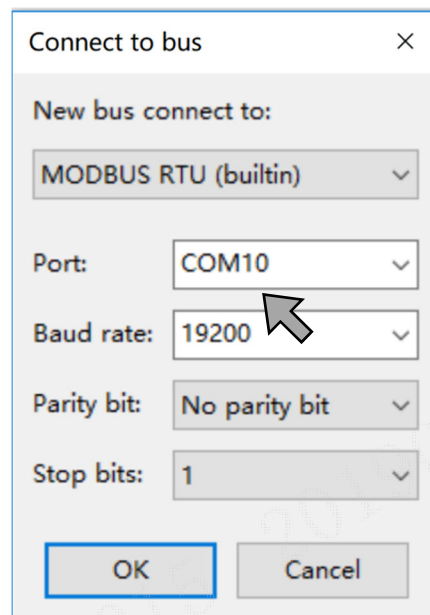

## 9.2 Operating the software

### 1) LIVE MONITOR: Monitoring and control on line.

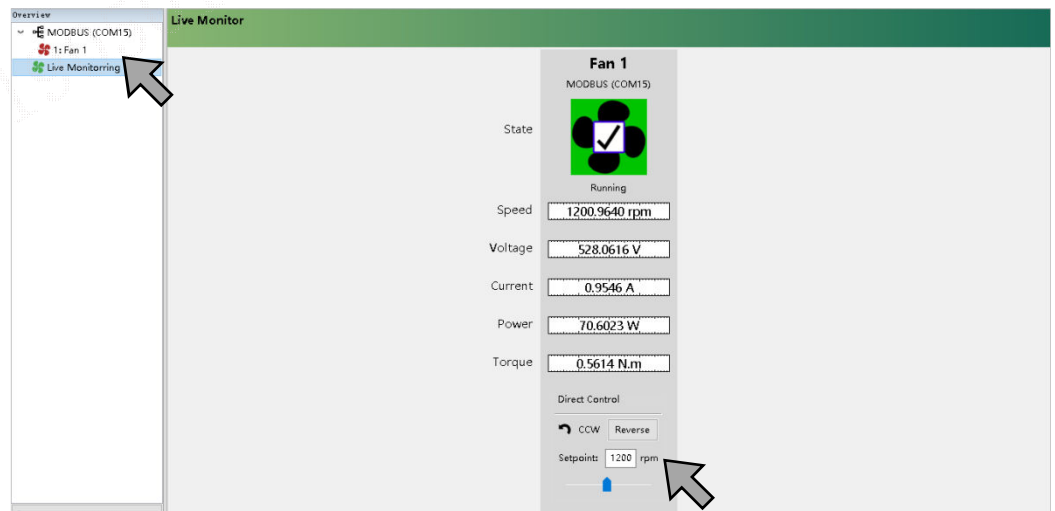

- In the left pane the connected FAN's are displayed
- When a Unit is in STOP mode, the OFF flag is blinking
- The bottom section shows the LOG



#### NOTE!

This LOG file is automatically saved on the user computer when the session is ended.

## 2) PARAMETER SETTINGS: ON LINE editing SINGLE Parameter

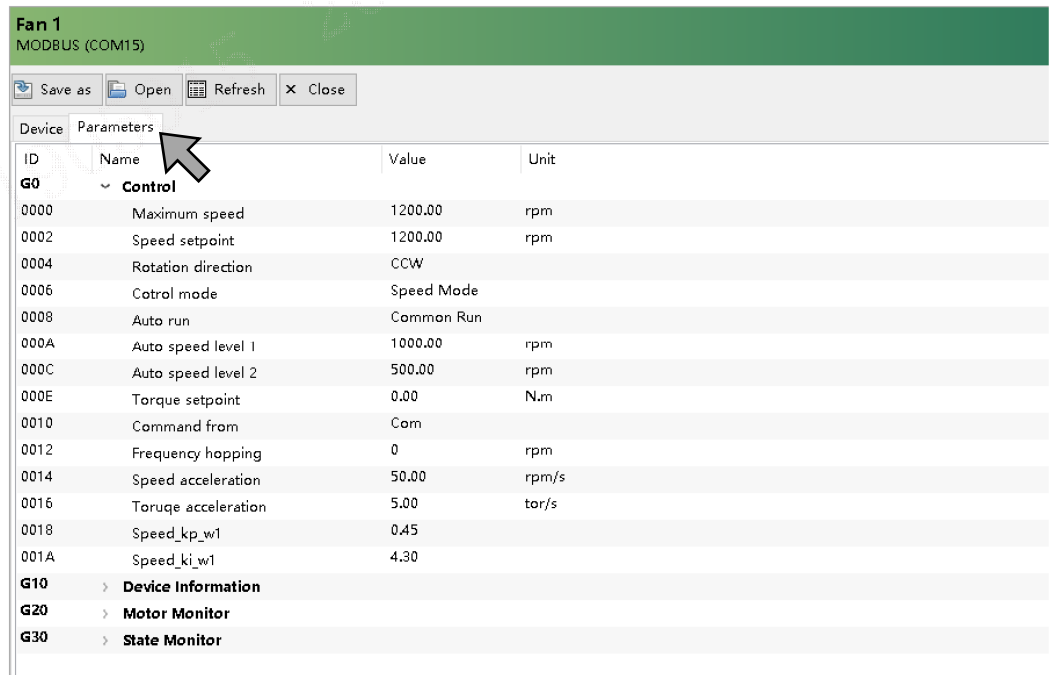

ID	Name	Value	Unit
<b>G0 Control</b>			
0000	Maximum speed	1200.00	rpm
0002	Speed setpoint	1200.00	rpm
0004	Rotation direction	CCW	
0006	Control mode	Speed Mode	
0008	Auto run	Common Run	
000A	Auto speed level 1	1000.00	rpm
000C	Auto speed level 2	500.00	rpm
000E	Torque setpoint	0.00	N.m
0010	Command from	Com	
0012	Frequency hopping	0	rpm
0014	Speed acceleration	50.00	rpm/s
0016	Torque acceleration	5.00	tor/s
0018	Speed_kp_w1	0.45	
001A	Speed_ki_w1	4.30	
<b>G10</b>	Device Information		
<b>G20</b>	Motor Monitor		
<b>G30</b>	State Monitor		

- Select the Fan
- Select PARAMETERS tab.
- The parameter group list is displayed
- To change a parameter Open the appropriate group
- Select the Parameter to change
- Confirm to WRITE the parameter to the unit

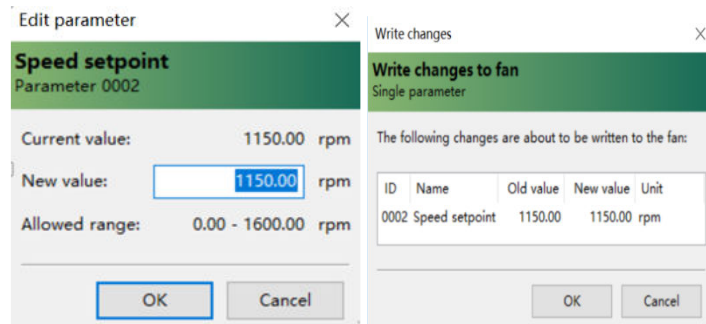

**Edit parameter**

**Speed setpoint**  
Parameter 0002

Current value: 1150.00 rpm

New value:  rpm

Allowed range: 0.00 - 1600.00 rpm

OK Cancel

**Write changes**

Write changes to fan  
Single parameter

The following changes are about to be written to the fan:

ID	Name	Old value	New value	Unit
0002	Speed setpoint	1150.00	1150.00	rpm

OK Cancel

## 5) MANAGING FILES ON LINE

- Also a previous saved file can be opened in this screen.
- The red figures indicated they have not the default value

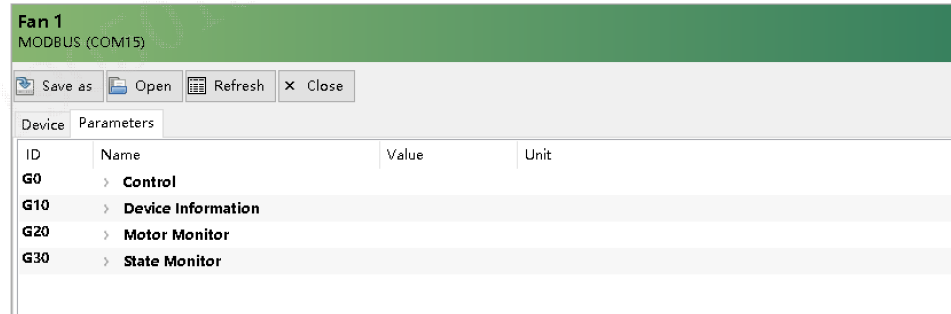

- SAVE AS: to save the file
- OPEN: Open an existing file
- REFRESH: refresh the data
- CLOSE: Close the file

## 6) MANAGING FILES OFF LINE

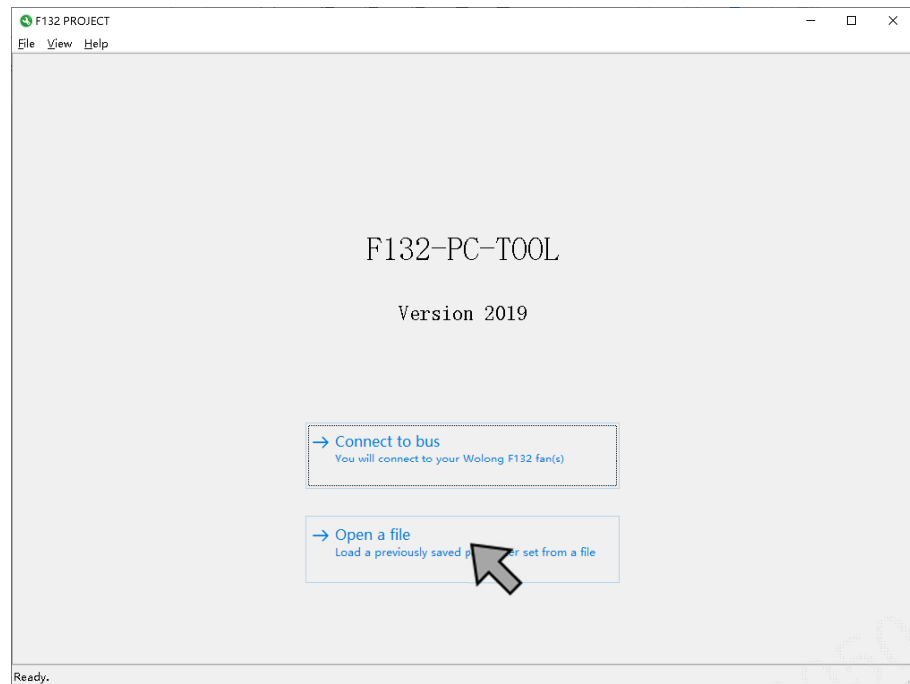

## 10 TROUBLESHOOTING

The EC motor has protection features implemented which will cause the motor to switch off (trip) to prevent damage to the unit. When the problem cause is found and resolved, the EC motor can be restarted by a reset command.

Error message	Possible cause	Remedy
Rotor blocked	Torque limit at motor standstill due to mechanical blocking of the (load on the) motor shaft.	Switch off supply and check for mechanical problems at the motor or connected machinery; remove mechanical blockage.
Overcurrent	Internal motor current exceeds the peak inverter current: <ul style="list-style-type: none"> <li>- Too high motor load</li> <li>- Too fast acceleration of motor speed</li> <li>- Excessive motor load change</li> <li>- Internal short-circuit between motor phases or phase to earth</li> </ul>	Check the motor load. Check on water and moisture in the motor housing (drainage holes). Check the acceleration ramp time setting and make it longer if necessary.
Overvoltage	Too high DC-link voltage by <ul style="list-style-type: none"> <li>- excessively high input voltage or alternator operation</li> <li>- Too short deceleration ramp time with respect to the machine inertia</li> <li>- Too high motor speed in wrong direction</li> </ul>	Check the main supply voltage. Check if the motor is in alternator operation. Check the deceleration ramp time setting and make it longer if necessary. Check air current in reverse direction.
Undervoltage	Too low DC-link voltage by <ul style="list-style-type: none"> <li>- too low or no supply voltage</li> <li>- voltage dip due to starting other major power consuming machines on the same line</li> </ul>	Check and make sure all 3 supply phases are properly connected. Check the supply voltage is within the limits of the EC motor. Use other supply lines if dip is caused by other machinery.
Phase Error	Too high ripple voltage on DC-link by input line voltage unbalance or (partly) missing supply voltage phase.	Check and make sure all 3 supply phases are properly connected. Check all 3 supply voltage phases are equal high and within the limits of the EC motor.
IGBT overtemperature	Too high temperature of power semiconductor by <ul style="list-style-type: none"> <li>- Too high ambient temperature</li> <li>- Too high motor load</li> <li>- Insufficient cooling</li> <li>- Too high current</li> </ul>	Check the cooling air temperature and reduce if necessary. Check the motor housing for dirt or garbage which blocks proper cooling. Check and make sure the motor load is within the limits of the EC motor. Check the motor for too heavy rotation or damaged/worn-out bearings.
OverSpeed	The motor runs faster than 1700RPM	Check if the controller is abnormal
HardwareOverCur	Hardware exception	Confirm if the controller is abnormal
WatchdogFailure	<ul style="list-style-type: none"> <li>- MCU damage</li> <li>- MCU is abnormal</li> </ul>	Power on again Replacement controller
Communication_error	Exceeded delay time in serial communication by: <ul style="list-style-type: none"> <li>- Missing or disrupted Modbus serial communication between EC motor and external control device.</li> <li>- Misfit between set watchdog delay time in EC motor and the serial communication protocol.</li> </ul>	Check the serial communication connections and wiring. Check with RS485 communication correct positioning and usage of termination and biasing networks. Check set Modbus Watchdog time in EC motor and adapt to protocol if necessary. Disable Modbus Watchdog by setting the delay time to 0.

---

## 11 MAINTENANCE

The EC motor is designed not to require any servicing or maintenance. There are however some things which must be checked regularly to safeguard a good and safe operation.

Regularly to check	Method	Maximum check interval
Damage of the EC motor	Visual inspection	6 months
Clean fins of EC motor housing for good cooling	Visual inspection	6 months; strong dependent of environmental conditions.
Fastening of cables and glands	Visual inspection	6 months
Damage of cables insulation	Visual inspection	6 months

When issues are found during any of the visual inspections, effective corrective measures have to be taken to assure a good and safe operation of the EC motor.

## 12 DISPOSAL

The end of life treatment of the EC motor should be handled by selective and professional recyclers, and complying with local and (inter)national regulations in force for the disposal and recycling of the dismantled materials.

The main parts of the EC motor can be recycled to preserve natural resources and energy, when materials are dismantled and separated. Generally all metals, such as steel, aluminum, copper, precious metals, rare earth magnets, and plastics can be recycled as material. Printed circuit boards, including electrolytic DC-link capacitors, need selective treatment according to IEC/TR 62635 guidelines.

Contact the local distributor for any other questions concerning the disposal of the EC motor.