

SMART DIFFERENTIAL PRESSURE TRANSMITTER

for low ranges APRE-2000G



min. range
0.2 mbar

- ✓ Programmable range, zero shift, damping ratio and characteristic
- ✓ 4...20 mA output signal + HART protocol
- ✓ Accuracy from 0.1%
- ✓ ATEX Intrinsic safety (only APRE-2000G/PD, APRE-2000G/PZ)

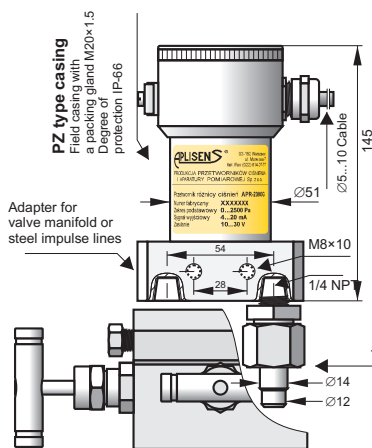

APRE-2000G Industrial Version, C type process connector to be mounted along with a valve manifold an example with **PZ type** Electrical Connection

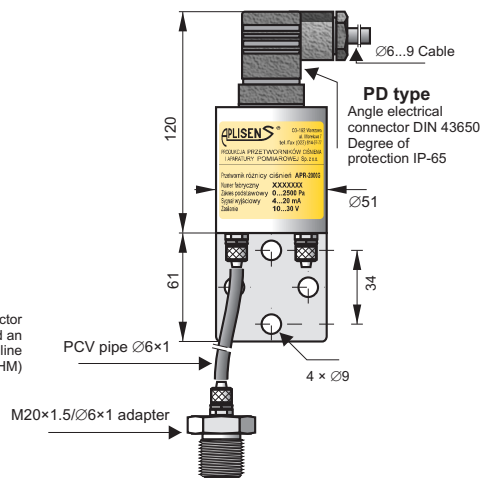

APRE-2000G Economic Version, process connection with terminal connecting to Ø6 pipe (**PCV type**). An example with **PD type** Electrical Connection



APRE-2000G/N wall-mounted version with display and local keys allowing programming, process connection **PCV type**. Dimensions: width: 80, height: 110, depth: 67

Application

The APRE-2000G transmitter is applicable to gases, to the measurements of their pressure, underpressure and differential pressure. Typical applications include the measurement of blast pressure, chimney draughts or pressure / underpressure in furnace chambers. The ability to select the radical conversion characteristics enables the transmitter to be used in gas-flow measurement systems using reducing pipes or other impeding elements. The transmitter can withstand overpressure up to 1 bar. The housing of the electronic circuit has the degree of protection IP65, IP66, IP67.

Configuration, calibration

The following metrological parameters can be configured:

- ◆ The units of pressure,
- ◆ Start and end-points of measuring range, damping time constant,
- ◆ Conversion characteristic (radical, inversion, user's non-linear characteristic).

Ability to calibrate the transmitter with reference to a standard pressure.

Communication

Communication with the transmitter is carried out with a KAP-03 communicator, some other Hart communicators or a PC with an Hart/USB/Bluetooth converter and RAPORT 2 configuration software.

Additionally, the data interchange with the transmitter enables the users to identify the transmitter, read the currently measured pressure difference value, output current and percentage of measuring range.

Installation

The economical version can be mounted on any stable construction using the assembly fixture with Ø9 opening. The transmitter's connection shanks have terminals to be connected to the elastic Ø6x1 impulse line. Where the pulse comes through a metal pipe, we suggest an M20x1.5 adapter for a Ø6x1 fitting using.

The transmitter with a C type connector should be mounted on a 3- or 5-valve manifold. We recommend to use our pre-assembled transmitters with VM type valves (page IV/ 2).

Operating guidelines

The transmitter should be mounted in a vertical position. The impulse lines should be connected in such a way that any condensed liquids flow off away from the device.

Where there is a significant difference in height between the place where the transmitter is mounted and the place where the pulse is taken, the measurement may vary with the temperature of the impulse line. Connecting a compensating pipe close to the impulse line, from the transmitter's reference connection shank to the height at which the impulse is taken can minimise this effect.

To prevent dust from entering the measuring cells, the impulse lines should be attached with care, with particular attention to the tightness of the connections between the impulse lines and the transmitter.

Measuring ranges

Nominal measuring range (FSO)	Minimum set range	Overpressure limit	Static pressure limit
0...25 mbar (0...2500 Pa)	1 mbar (100 Pa)	1 bar	350 mbar
-2,5...2,5 mbar (-250...250 Pa)	0,2 mbar (20 Pa)	350 mbar	350 mbar
-7...7 mbar (-700...700 Pa)	1 mbar (100 Pa)	350 mbar	350 mbar
-25...25 mbar (-2500...2500 Pa)	5 mbar (500 Pa)	1 bar	1 bar
-100...100 mbar (-10...10 kPa)	20 mbar (2 kPa)	1 bar	1 bar

Meterological parameters

Nominal range	0...25 mbar	-2,5...2,5 mbar	-7...7 mbar	-25...25 mbar	-100...100 mbar
Accuracy	≤ ±0,075%	≤ ±0,25%	≤ ±0,1%	≤ ±0,1%	≤ ±0,075%

Thermal error < ±0,1% (FSO) / 10°C
max. ±0,4% (FSO) in the whole compensation range

Thermal compensation range -10...70°C

Additional electronic damping 0...30 s

Error due to supply voltage changes 0,002% (FSO) / V

Electrical parameters

Power supply

APRE-2000G/PD and PZ 7,5...55 VDC (Ex ia 7,5...28 VDC)

APRE-2000G/N 12...36 VDC

(Additional voltage drop when display illumination switched on: 3V)

Output signal 4...20 mA, two wire transmission

Load resistance $R[\Omega] \leq \frac{U_{sup}[V] - U^*}{0,0225A}$

U* - APRE-2000G/PD and PZ: 7,5 VDC

APRE-2000G/N: 12 VDC

Resistance required for communication min. 240 Ω

Operating conditions

Operating temperature range (ambient temp.) -30...85°C

Exia version: -25...80°C

APRE-2000G/N: -25...80°C

Materials

APRE-2000G/PD and PZ:

Casing SS304

adapter C type SS304

adapter PCV type (on Ø6 elastic pipe) brass

APRE-2000G/N:

Casing plastic box

Electrical diagram

APRE-2000G/N APRE-2000G/PZ APRE-2000G/PD

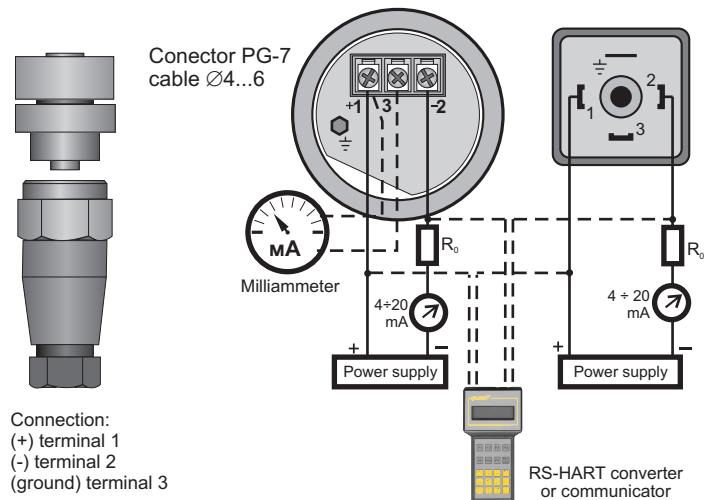

Ordering procedure

Model	Code	Description
APRE-2000G		Smart differential pressure transmitter
Certificates	/Exia.....	 II 1/2G Ex ia IIC T4/T5 Ga/Gb II 1 D Ex ia IIIC T110°C Da I M1 Ex ia I Ma
Casing, output signal	/PD..... /PZ..... /N.....	Housing IP65 with DIN43650 connector, without display, output 4-20mA + Hart 304SS housing, IP66, without display, output 4-20mA + Hart Housing IP65, electrical connector PG-7 (ATEX version not available)
Nominal measuring range	/0+25 mbar.....	Range
	/-2,5+2,5 mbar..... /-7+7 mbar..... /-25+25 mbar..... /-100+100 mbar.....	Min. set range
		0+25 mbar (0+2500 Pa) -2.5+2.5mbar (250+250 Pa) -7+7 mbar (700+700 Pa) -25+25 mbar (2500+2500 Pa) -100+100mbar (10+10 kPa)
		1mbar (100 Pa) 0,2 mbar (20 Pa) 1mbar (100 Pa) 5mbar (500 Pa) 20mbar (2 kPa)
Measuring set range	/...+... [required units]	Calibrated range in relation to 4mA and 20mA output
Process connections	/PCV.....	Process connection with terminal connecting for Ø6mm elastic pipe. Mounting bracket for wall mounting is a standard. Thread 1/4 NPT F on cover flange. Material of cover flange 304ss. Allows mounting with a valve manifold.
	/C.....	
Accessories	/M20x1,5/Ø6.....	Adapter from Ø 6mm elastic pipe for M20x1,5 M thread (only version with PCV process connection)
	/RedSpaw C.....	Connector to weld impulse pipes dia. 12 and 14 mm, material 15HM. (only version with process connection C type)
	/+VM-3/A.....	Assembled with a 3-way valve manifold (further specification of manifold - see data sheet) . Only version with C type process connection.
	/+VM-5/A.....	Assembled with a 5-way valve manifold (further specification of manifold - see data sheet) . Only version with C type process connection.
Other specification	/.....	Description of required parameters

Example 1: Differential pressure transmitter , nominal measuring range -7...7mbar, stainless steel casing, calibrated 0,5..1mbar, process connection PCV to elastic pipe Ø6mm plus two adapters from elastic pipe Ø6mm for M20x1.5 M thread

APRE-2000G/PZ/-7...7mabr/-0,5...1mbar/PCV/M20x1,5/Ø6mm (x2)

Example 2: Differential pressure transmitter , nominal measuring range -7...7mbar, calibrated 0...7mbar process connection PCV to elastic pipe Ø6mm, wall mounted version

APRE-2000G/N/-7...7mabr/0...7mbar/PCV