

# Glycerine filled Bourdon tube pressure gauges EN 837-1

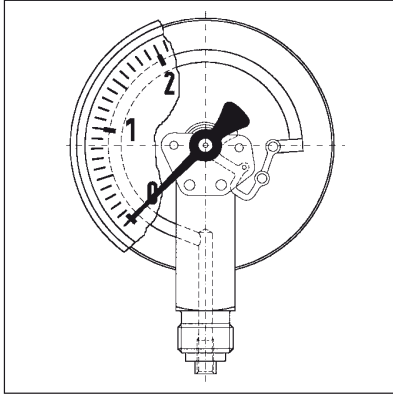

## Application

For gaseous and liquid media which are not highly viscous, do not crystallize and do not attack copper alloys.

For measurement in areas with high levels of vibration and high, dynamic pressure loads.

! When measuring gas or vapour, the instruments must be used in accordance with the safety recommendations of EN 837-2 (see appendix).

## Type

D 7

## Nominal size

50 – 63

## Accuracy class (EN 837-1/6)

1.6

## 11 Ranges (EN 837-1/5)

-1/0 to -1/+15 bar

0/0.6 to 0/400 bar

NG 63 to 0/600 bar

## Application area

Static load:

$\frac{3}{4}$  x full scale value

Dynamic load:

$\frac{2}{3}$  x full scale value

Short term:

full scale value

## Operating temperature range

Medium:  $T_{max} = +60\text{ }^{\circ}\text{C}$

Ambient:  $T_{min} = -20\text{ }^{\circ}\text{C}$

$T_{max} = +60\text{ }^{\circ}\text{C}$

## Temperature performance

Indication error when the temperature of the measuring element deviates from 20 °C:

rising temp. approx.  $\pm 0.4\text{ } \%$  /10 K

falling temp. approx.  $\pm 0.4\text{ } \%$  /10 K

percentage of full scale value

## Protection

IP 65 (EN 60529)

with housing vent ( $\leq 25\text{ bar}$ )

IP 54

## Standard version

### Connection

Brass, bottom or centre back

G $\frac{1}{4}$ B - spanner size 14

(EN 837-1/7.3)

### Measuring element

Bourdon tube element, copper alloy

$\leq 60\text{ bar}$  „C“ type bourdon tube

$> 60\text{ bar}$  helical tube

## Movement

Brass

## Dial

Aluminium, white

Dial marking black

## Pointer

Aluminium, black

## Housing

Stainless steel 304

with pressure relief port

## Crimped bezel

Stainless steel 304

## Front glass

Plastic

## Filling liquid

Glycerine (99.5 %)

## Options

- Filling liquid silicone oil
- Back flange (NG 63)
- Clamp fixing
- 3-hole fixing, panel mounting bezel (NG 63)
- Crimped bezel, polished
- Special scales
- Damping screw