

FEATURES

These stainless steel cylinders are designed for use in corrosive environments:

- chemical, salty or humid atmospheres
- food processing, dairy and meat industries: high resistance to lactic acid and bactericidal sprays

GENERAL

Detection	Equipped for magnetic position detectors
Operating pressure	10 bar, max. [1 bar = 100 kPa]
Ambient temperature	-20°C to +80°C
Standards	ISO 6431

fluids (*)	temperature range (TS)
air or inert gas filtered at 50 µm, lubricated or not	-20°C to +80°C



MATERIALS IN CONTACT WITH FLUID

(*) Ensure that the compatibility of the fluids in contact with the materials is verified

Barrel	Stainless steel, AISI 304
Rod	Stainless steel, AISI 303, AISI 316 L
Rod seal	FPM (fluoroelastomer)
Front and rear ends	Stainless steel, AISI 304
Piston	Light alloy - POM Acetal
Piston seal	PUR (polyurethane)
Scraper seal	FPM (fluoroelastomer), PTFE in option
CONSTRUCTION	
Cushioning	Adjustable pneumatic
Dismounting	Dismountable cylinder
Rod nut	Stainless steel, AISI 316 L
Bearing	Composite material

HOW TO ORDER

15-DIGIT PRODUCT CODE
G 431 A 5 3 K 0080 A00

Thread connection
G = ISO 16030

Product series
431

Revision letter
A = Initial release

Diameter (mm)
3 = 32
4 = 40
5 = 50
6 = 63
8 = 80

Rod options
3 = Single rod, Stainless steel
4 = Through rod, Stainless steel
6 = Single rod, AISI 316 L
7 = Through rod, AISI 316 L

Rod seal and rod scraper seal
K = FPM Rod Seal (Standard)
P = FPM Rod Seal + PTFE Rod Scraper seal
C = FPM Rod Seal + PTFE Detachable Rod Scraper seal Cartridge

Options

- A00** = Single rod, Plain Front & Rear Covers
- PRC** = Single rod, Threaded Front Cover, Plain Rear Cover
- TRE** = Single rod, Plain Front Cover, Integral-Eye Rear End
- THR** = Through rod (Threaded Covers)

Recommended standard strokes (mm) ⁽¹⁾

Ø mm	con-nect. Ø (G)	25	50	80	100	125	160	200	250	320	400	500	max. stroke
32	G1/8	●	●	●	●	●	●	●	●				1000
40	G1/4	●	●	●	●	●	●	●	●	●			1000
50	G1/4	●	●	●	●	●	●	●	●	●	●		1000
63	G3/8	●	●	●	●	●	●	●	●	●	●		1000
80	G3/8	●	●	●	●	●	●	●	●	●	●		1000

⁽¹⁾ Other strokes on request. / Min. stroke: 5 mm





[Configurator - CAD Files](#)



POSITION DETECTORS

[IP69K Magnetic position detector](#) and [stainless steel collars](#)

INSTALLATION

- The cylinders can be mounted in any position without affecting operation
- Stainless steel mountings: **catalogue number**

Ø (mm)	 female rod clevis ISO 8140 AP2	 spherical rod end ISO 8139 AP6	 front neck nut MR3	 feet MS1
32	P493A3131200A00	P493A3132200A00	P493A332F200A00	P493A3324200A00
40	P493A4131200A00	P493A4132200A00	P493A432F200A00	P493A4324200A00
50	P493A5131200A00	P493A5132200A00	P493A532F200A00	P493A5324200A00
63	P493A5131200A00	P493A5132200A00	P493A532F200A00	P493A6324200A00
80	P493A8131200A00	P493A8132200A00	P493A832F200A00	P493A8324200A00

Ø (mm)	 cap, detachable eye (trunnion) MP4	 cap, eye with spherical bearing MP6	 cap, clevis for spherical eye
32	P493A3322210A00	P493A3328200A00	P493A332C200A00
40	P493A4322210A00	P493A4328200A00	P493A432C200A00
50	P493A5322210A00	P493A5328200A00	P493A532C200A00
63	P493A6322210A00	P493A6328200A00	P493A632C200A00
80	P493A8322210A00	P493A8328200A00	P493A832C200A00

- Pipe connections 1/4-3/8-1/2 (G*) have standard combination thread according to ISO 228/1 and ISO 7/1. Pipe connections G 1/8 have standard thread according to ISO 228/1
- Installation/maintenance instructions are included with each cylinder

DIMENSIONS (mm) 

[Configurator - CAD Files](#)



SINGLE-ROD TYPE CYLINDER
Plain Front & Rear Covers (option: A00)
For detachable rear mounting
Supplied without front cover nut
ISO 6431

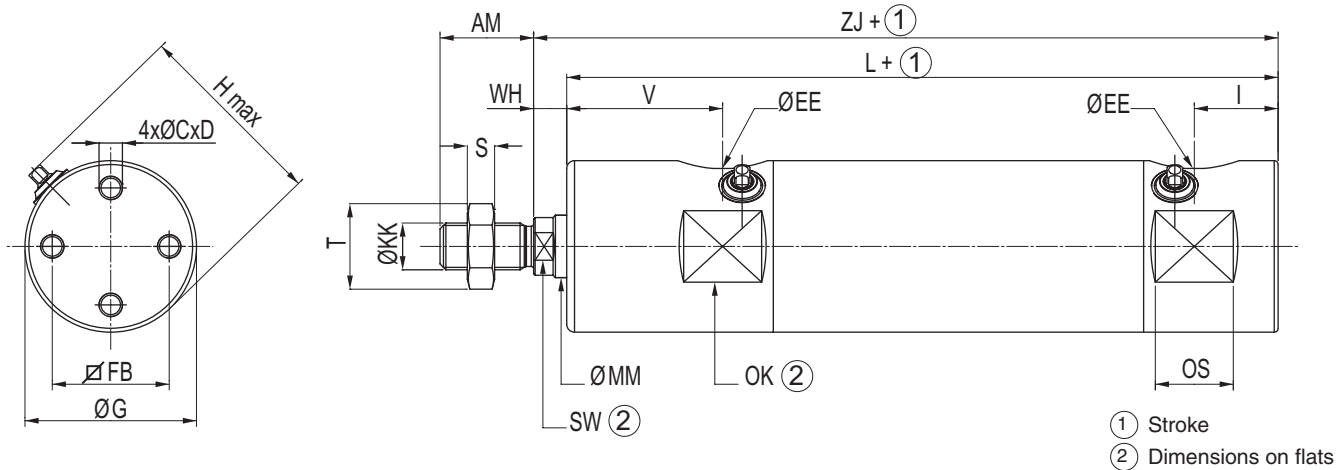

Ø (mm)	AM	C	D	ØEE	FB	G	H max.	I	ØKK	L	MM	OK	OS	S	SW	T	V	WH	ZJ
32	22	M5	7	G1/8	25	36	44,70	17,5	M10x1,25	115,5	12	33	16,5	5	10	17	34	8	123,5
40	24	M6	8	G1/4	30	44	52,45	21,5	M12x1,25	132,5	16	40	20	6	13	19	40	8,5	141
50	32	M6	8	G1/4	39	54	62,45	19	M16x1,5	135	20	50	19	8	17	24	44,5	13	148
63	32	M8	8	G3/8	49	68	76,45	22,5	M16x1,5	151	20	64	24	8	17	24	44	13	164
80	40	M10	8,5	G3/8	64	86	94,60	25,5	M20x1,5	164	25	82	24	10	21	30	51	15,5	179,5

DIMENSIONS (mm)

[Configurator - CAD Files](#)



SINGLE-ROD TYPE CYLINDER

Threaded Front Cover, Plain Rear Cover (option: **PRC**)
For detachable rear mounting
Supplied without front cover nut
ISO 6431

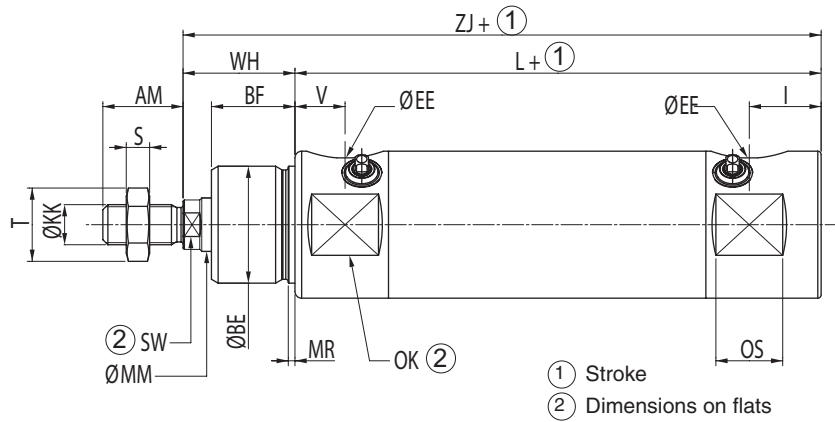
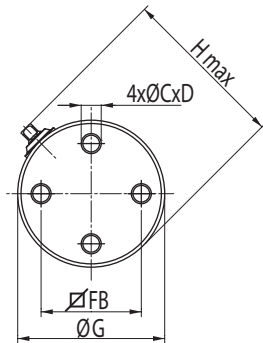

Ø (mm)	AM	BE	BF	C	D	ØEE	FB	G	H max.	I	ØKK	L	MM	MR	OK	OS	S	SW	T	V	WH	ZJ
32	22	M30x1,5	22	M5	7	G1/8	25	36	44,70	17,5	M10x1,25	92,5	12	2	33	16,5	5	10	17	12	31	123,5
40	24	M35x1,5	25	M6	8	G1/4	30	44	52,45	21,5	M12x1,25	106,5	16	2	40	20	6	13	19	15	34,5	141
50	32	M42x1,5	28	M6	8	G1/4	39	54	62,45	19	M16x1,5	107	20	2	50	19	8	17	24	16,5	41	148
63	32	M42x1,5	28	M8	8	G3/8	49	68	76,45	22,5	M16x1,5	123	20	2	64	24	8	17	24	16	41	164
80	40	M50x2,0	28	M10	8,5	G3/8	64	86	94,60	25,5	M20x1,5	136	25	2	82	24	10	21	30	23	43,5	179,5



SINGLE-ROD TYPE CYLINDER

Plain Front Cover, Tenon Rear End (option: **TRE**)
Supplied without front cover nut
ISO 6431

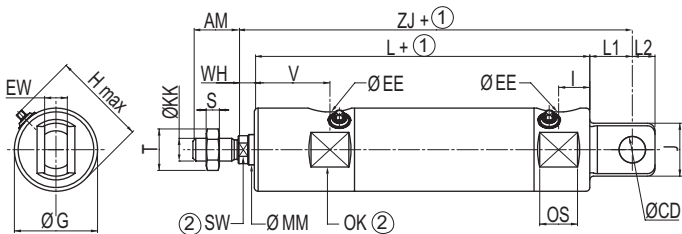

THROUGH-ROD TYPE CYLINDER

Threaded Covers (option: **THR**)
ISO 15552-AFNOR - DIN

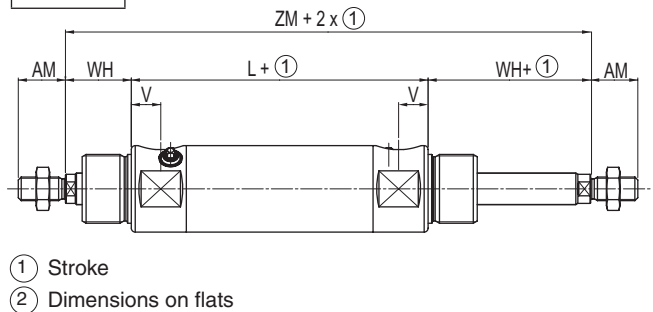

Ø (mm)	AM	ØCD	ØEE	G	H max.	I	J	ØKK	L	L1	L2 EW	MM	OK	OS	S	SW	T	V	WH	ZJ	Ø (mm)	AM	L	V	WH	ZM
32	22	10	G1/8	36	44,70	12	24	M10x1,25	109	22,5	10	12	33	16,5	5	10	17	34	8	140,5	32	22	88	12	31	150
40	24	12	G1/4	44	52,45	16,5	28	M12x1,25	126,5	22,5	12	16	40	20	6	13	19	40	8,5	158,5	40	24	101	15	34,5	170
50	32	16	G1/4	54	62,45	15,5	30	M16x1,5	131,5	27	16	20	50	19	8	17	24	44,5	13	171,5	50	32	105,5	16,5	41	187,5
63	32	16	G3/8	68	76,45	21,5	40	M16x1,5	150	27	16	20	64	24	8	17	24	44	13	190	63	32	117	16	41	199
80	40	20	G3/8	86	94,60	20	50	M20x1,5	158,5	36	20	25	82	24	10	21	30	51	15,5	210	80	40	134,5	23	43,5	221,5



OPTION

PTFE Detachable Rod Scraper seal Cartridge

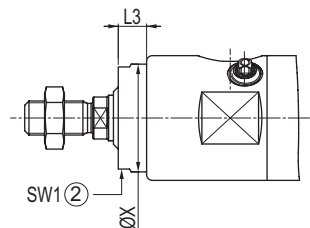
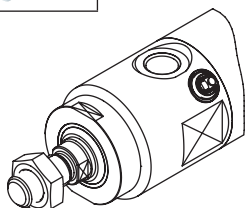

Ø (mm)	ØX	L3	SW1
32	31	5	27
40	38	5	36
50	40	5	36
63	40	5	36
80	53	5	46

DIMENSIONS (mm), WEIGHT (kg)

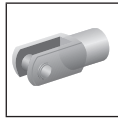

MOUNTING
Female rod clevis
ISO 8140
AP2

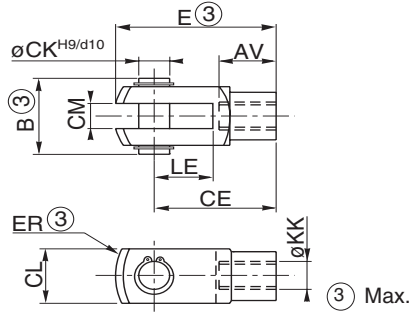

Ø (mm)	AV	B	CE	CK	CL	CM	E	ER	KK	LE	weight
32	20	26	40	10	20	10	52	13	M10x1,25	20	0,09
40	23	31	48	12	24	12	62	15	M12x1,25	24	0,16
50	34	39	64	16	32	16	83	20	M16x1,5	32	0,31
63	34	39	64	16	32	16	83	20	M16x1,5	32	0,31
80	40	48	80	20	40	20	105	25	M20x1,5	40	0,67

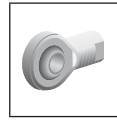

MOUNTING
Spherical rod end
ISO 8139
AP6

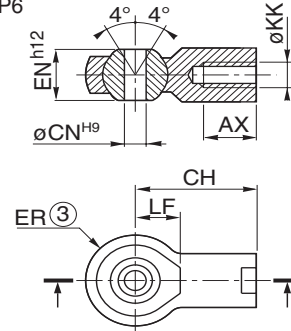

Ø (mm)	AX	CH	CN	EN	ER	LF	KK	weight
32	20	43	10	14	13	14	M10x1,25	0,076
40	23	50	12	16	15	16	M12x1,25	0,115
50	34	64	16	21	20	22	M16x1,5	0,230
63	34	64	16	21	20	22	M16x1,5	0,230
80	40	77	20	25	25	26	M20x1,5	0,415



MOUNTING
Feet
MS1

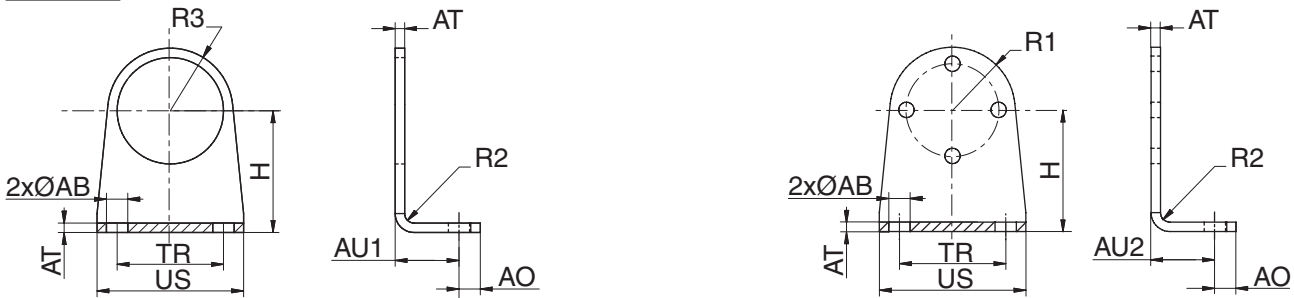

Ø (mm)	AB	AO	AU1	AU2	AT	H	R1	R2	R3	TR	US	weight
32	7	9	28,5	20,5	3	33	17,5	3	17,5	32	45	0,075
40	9	9	32	22	3	38	21,5	3	21,5	36	52	0,090
50	9	9	36	27	4	47	26,5	4	25	45	62	0,170
63	9	9	36	26	4	52	33	4	27	50	72	0,230
80	12	15	38,5	35,5	5	65	42,5	5	31	63	90	0,450

DIMENSIONS (mm), WEIGHT (kg)

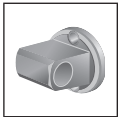

MOUNTING

Cap detachable eye (trunnion) mounting
MP4

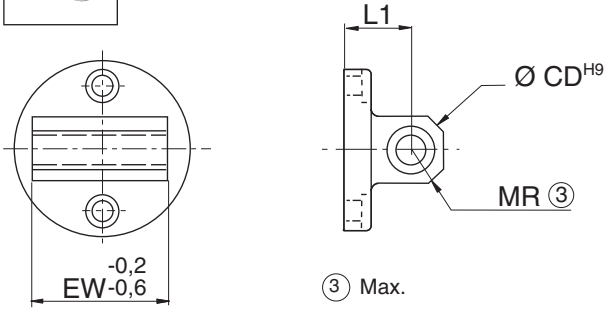

Ø (mm)	CD	EW	MR	L1	weight
32	10	26	11	18,5	0,08
40	12	28	13	19	0,10
50	12	32	13	22	0,17
63	16	40	17	26	0,32
80	16	50	17	30,5	0,58

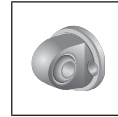

MOUNTING

Cap, detachable eye mounting with spherical bearing
MP6

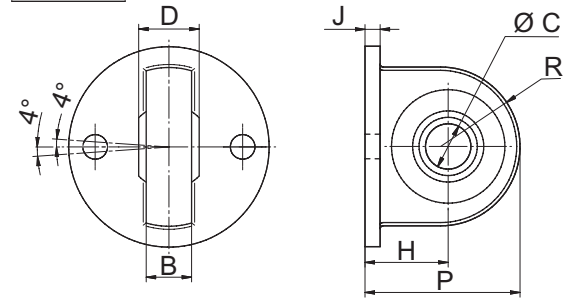

Ø (mm)	B	C	D	H	J	P	R	weight
32	10,5	10	14	18,5	3,5	33,5	15	0,09
40	12	12	16	19	3,5	37	18	0,14
50	12	12	16	22	5	44	22	0,22
63	15	16	21	26	5	48	22	0,34
80	15	16	21	30,5	8	55,5	25	0,60



MOUNTING

Cap, clevis for spherical eye

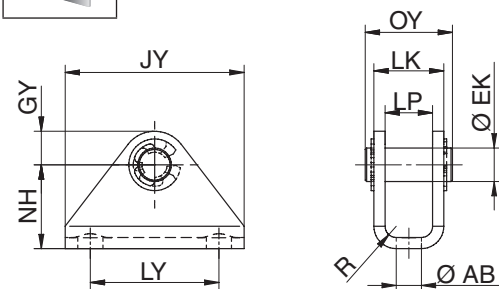

Ø (mm)	AB	EK	GY	JY	LK	LP	LY	NH	OY	R	weight
32	7	10	9	45	21	15	30	24	26	3	0,08
40	9	12	10	55	23	17	38	27	29	3	0,09
50	9	12	10	64	25	17	46	30	31	4	0,18
63	12	16	13	79	30	22	58	36	36	4	0,27
80	14	16	13	94	32	22	70	40	38	5	0,41

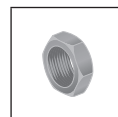

MOUNTING

Front neck nut
MR3

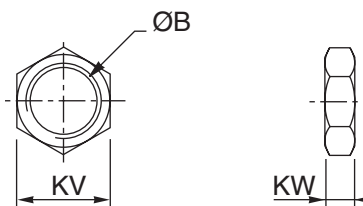

Ø (mm)	ØB	KV	KW	weight
32	M30x1,5	36	10	0,037
40	M35x1,5	41	10	0,043
50	M42x1,5	50	12	0,079
63	M42x1,5	50	12	0,079
80	M50x2	65	12	0,167

SPARE PARTS KITS CODE

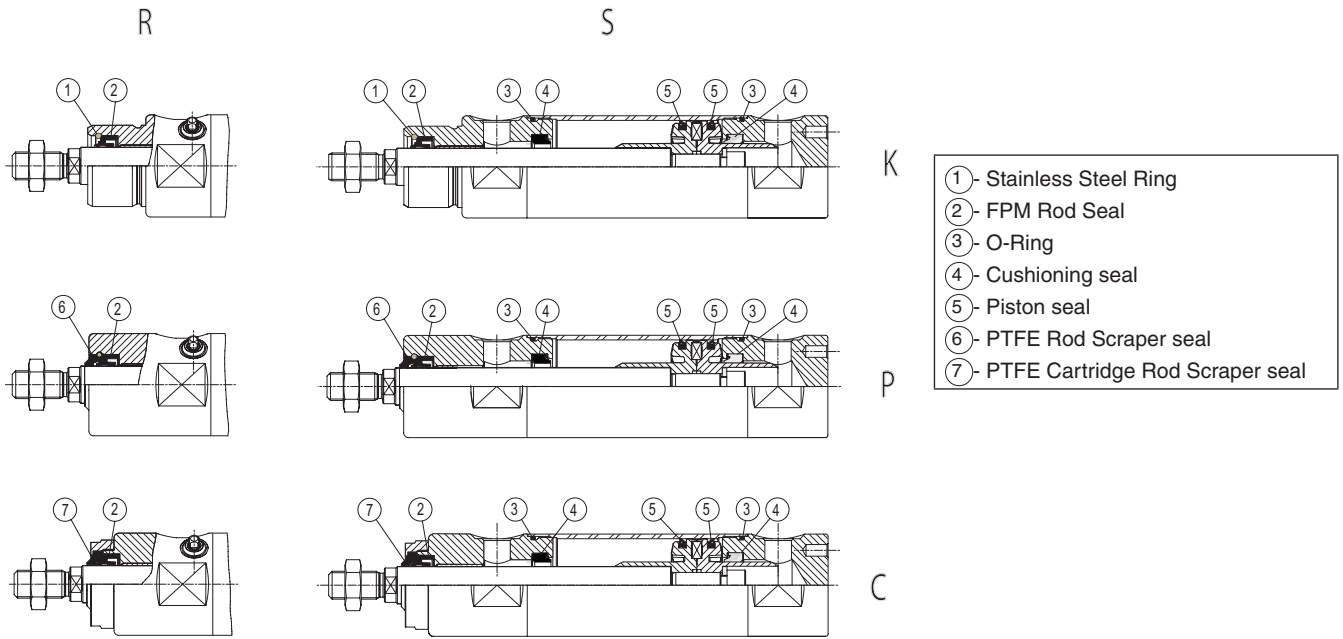

15-DIGIT PRODUCT CODE

M 431 A 5 S K 0000 A00

Spare Parts digit
M

Product series
431

Revision letter
A = Initial release

Diameter (mm)

- 3 = 32
- 4 = 40
- 5 = 50
- 6 = 63
- 8 = 80

Rod seal and rod scraper seal

K = FPM Rod Seal (Standard)

P = FPM Rod Seal + PTFE Rod Scraper seal

C = FPM Rod Seal + PTFE Cartridge Rod Scraper seal

Type of kit

S = Complete set of seals

R = Rod seals only

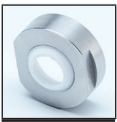

Cartridge with PTFE Rod Scraper seal

Ø (mm)	SPARE PARTS KITS CODE Cartridge with PTFE Rod Scraper seal
32	M431A3EC0000A00
40	M431A4EC0000A00
50-63	M431A5EC0000A00
80	M431A8EC0000A00