

Specifications

For other materials or modifications, please consult TESCO M.

OPERATING PARAMETERS

Pressure rating per criteria of ANSI/ASME B31.3

Maximum Inlet Pressure

400, 3500 psig
27.6, 241 bar

Outlet Pressure Ranges

0-25, 0-50, 0-100, 0-250, 0-500 psig
0-1.7, 0-3.4, 0-6.9, 0-17.2, 0-34.5 bar

Design Proof Pressure

150% maximum rated

Leakage

Internal: Bubble-tight

External: Design to meet $\leq 2 \times 10^{-8}$ atm cc/sec He

Operating Temperature

-40°F to 165°F / -40°C to 74°C

Flow Capacity

3500 psig / 241 bar Inlet: $C_v = 0.06$

400 psig / 27.6 bar Inlet: $C_v = 0.15$

Maximum Operating Torque

30 in-lbs / 3.4 N•m

MEDIA CONTACT MATERIALS

Body

316L Stainless Steel, Brass, Nickel Alloy (Hastelloy®)* or Nickel Alloy (Monel®)

Bonnet

300 Series Stainless Steel, Brass

Diaphragm

316 Stainless Steel, Cobalt Chrome Nickel Alloy (Elgiloy®)

Seat

PTFE

Remaining Parts

316 Stainless Steel, Brass, Nickel Alloy (Hastelloy®)* or Nickel Alloy (Monel®)

OTHER

Cleaning

CGA 4.1 and ASTM G93

Internal Volume

6 cc

Weight (without gauges)

2 lbs / 0.9 kg

Teflon® is a registered trademark of E.I. du Pont de Nemours and Company.

Hastelloy® is a registered trademark of Haynes International, Inc.

Elgiloy® is a registered trademark of Elgiloy Corp.

**Material to be Hastelloy® or equivalent per ASTM B 574*

NOTE:

When choosing a regulator and control pressure, decaying inlet characteristic must be considered when the supply pressure is expected to change. The decaying inlet characteristic of a pressure reducing regulator is commonly known as the increase in control pressure due to the decrease in supply pressure. It is important to make sure this effect does not cause the control pressure to exceed the pressure rating of the unit's outlet or that of the downstream system.

For more information on decaying inlet, please refer to the Technical Information section of the product catalog and/or contact the TESCO M customer support further assistance.



TESCOM 44-2200 Series is a compact, lightweight high purity single-stage regulator for specialty, flammable, and industrial gas flows of less than 5 SCFM / 141 SLPM. Its diffusion-resistant metal diaphragm seal ensures gas purity and integrity.

Applications

- Laboratory and point-of-use gas systems
- Sampling systems, zero, span and calibration analyzer gases
- Specialty and industrial gas cylinder regulator
- Chromatograph flame detector fuel supply

Features and Benefits

- Compact
- Designed to minimize contamination and provide accurate regulation of any corrosive, non-corrosive, or toxic gas
- Brass model provides added economy for control of non-corrosive media
- Metal-to-metal diaphragm to body seal ensures minimum inboard and outboard leakage
- Convoluted diaphragm delivers excellent accuracy and long service life
- Panel mounting is available
- 300 Series Stainless Steel or Brass bonnet
- NACE compliant designs are available

44-2200 SERIES

44-2200 Series Regulator Drawing

PORTING CONFIGURATION

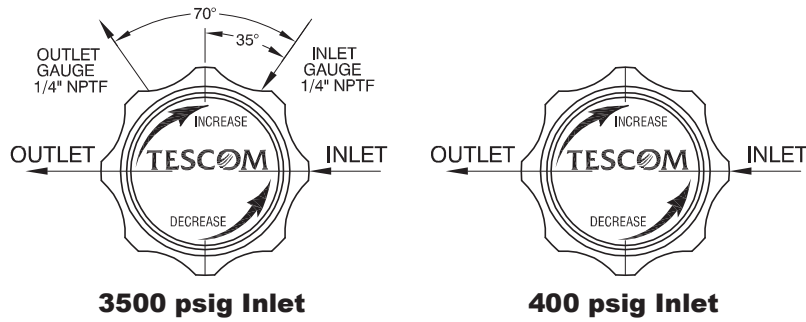

3500 psig Inlet

400 psig Inlet

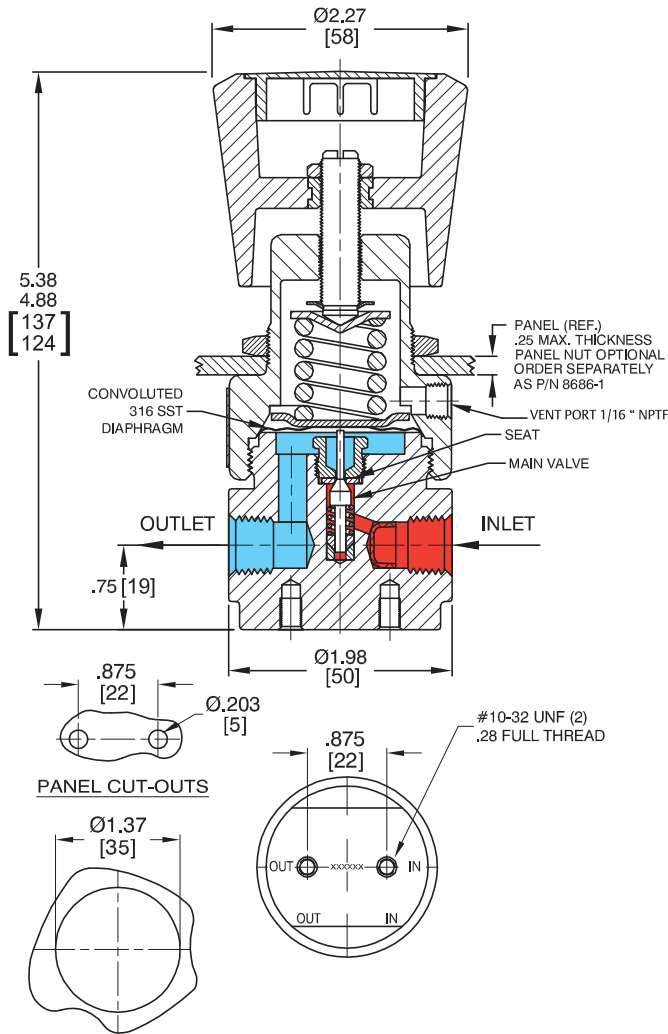

All dimensions are reference & nominal
Metric [millimeter] equivalents are in brackets

44-2200 Series Regulator Flow Charts

For more information on how to read flow curves, please refer to the Flow Curves and Calculations document (debul2007x012) in the TESCOM catalog or on www.tescom.com.

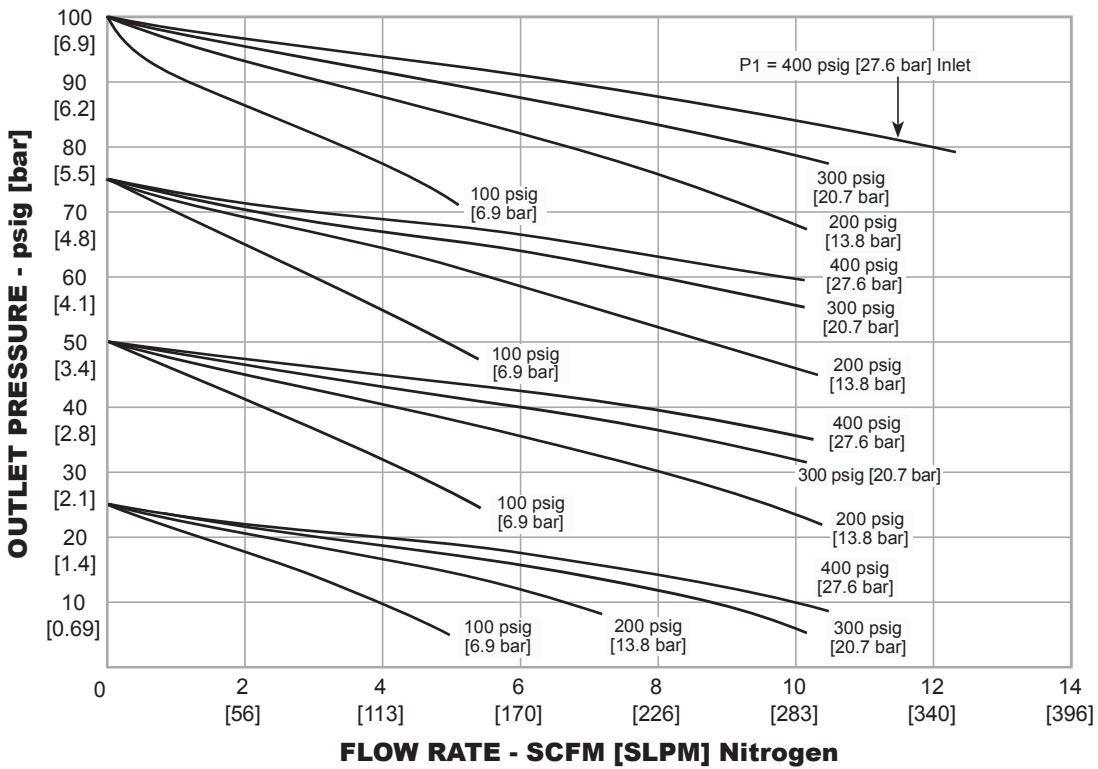
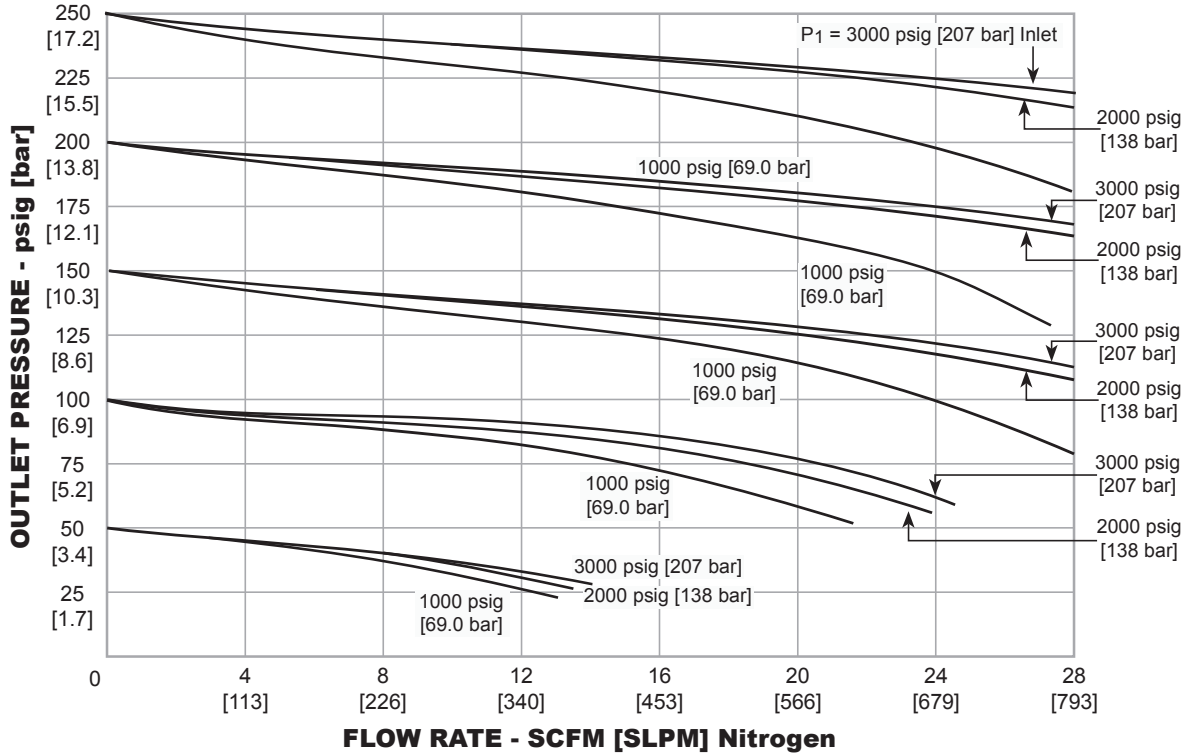

44-2200 SERIES

44-2200 Series Regulator Part Number Selector

Repair Kits, Accessories & Modifications may be available for this product. Please contact TESCOM for more information.

Example for selecting a part number:

44-22 6 0 - 2 4 1

| BASIC SERIES | BODY MATERIAL | OUTLET PRESSURE RANGES | INLET AND OUTLET PORT TYPE | INLET AND OUTLET PORT SIZE | INLET PRESSURE | FLOW CAPACITY | MODIFICATIONS |
|--------------|-------------------------------|---------------------------------------|----------------------------|----------------------------|----------------------------------|---------------|---|
| 44-22 | 1 – Brass | 0 – 0-25 psig 0-1.7 bar | 2 – NPTF | 4 – 1/4" | 1 – 3500 psig 241 bar | $C_v = 0.06$ | -010 – Outlet gauge port at 90° -115 – High temperature (400°F / 205°C) -118 – Hydraulic service outlet gauge ports at 70° |
| | 5 – Nickel Alloy (Hastelloy®) | 1 – 0-50 psig 0-3.4 bar | | | 2 – 400 psig 27.6 bar | $C_v = 0.15$ | |
| | 6 – 316L Stainless Steel | 2 – 0-100 psig 0-6.9 bar | | | <i>See porting configuration</i> | | |
| | 9 – Nickel Alloy (Monel®) | 3 – 0-250 psig 0-17.2 bar | | | | | |
| | | 4 – 0-500 psig 0-34.5 bar | | | | | |
| | | (with 3500 psig / 241 bar inlet only) | | | | | |